

Control Peach Tree Borers on Commercially Grown Peach and Plum Trees

Glenn E. Studebaker
Assistant Professor,
Extension Entomologist

John Hopkins
Assistant Professor,
Extension Entomologist

Donn T. Johnson
Entomology Professor

Peach tree borers may kill your peach and plum trees by girdling the trunk. Lesser peach tree borer larvae enter wounds in limbs, further weakening them and allowing secondary infections to occur. Proper thinning of fruit will prevent over-cropping and will lessen limb breakage and attack by lesser peach tree borer. Infested trees which survive are weak and unthrifty. One or two treatments with recommended chemicals will protect trees for the entire year. Pheromone traps (traps which attract borer adults as they emerge) are available for purchase for those who want to better time their application for their orchards.

Recognizing the Injury

You can recognize peach tree borer injury by gum that oozes out at the base of the tree. Borers may be found by checking under the bark. The borer usually works at or slightly below the surface of the soil. Gum or reddish-brown frass is often found on the trunk or larger branches some distance above the ground. This is usually a result of mechanical injuries or damage by other insects, such as lesser peach tree borer or shothole borer.

Description of the Peach Tree Borer

The peach tree borer adult female is a blue-black colored, clear-winged moth with an orange band around the abdomen. The male moth is smaller and more slender. It is also blue-black but has six obvious narrow yellow bands around the abdomen. Both pairs of wings are clear.

The borer is a white larva or grub up to 1 1/4 inches long found feeding under the bark, usually at or below the soil line. The larvae of borers transform to the pupa or resting stage from April to August. Moths may begin emerging in late May. They may continue to emerge throughout the summer. Eggs are laid on the bark where the tiny borers hatch and immediately begin to chew their way into the tree at or below the soil line.

Trunk Spraying for Control

The information on control of borers in this fact sheet is intended for commercially grown peach and plum trees. Many of the materials listed are not labeled for use in backyard plantings. For information on controlling borers in backyard or home orchard plantings, refer to our fact sheet *Home Fruit Orchard Sprays*, FSA7503.

Spraying the lower trunk of trees before the newly hatched borers enter the tree is an economical and easy method of controlling peach tree borers. Newly hatched borers are killed by the insecticide deposit before they enter the trunk.

Timing of the application is important. If your trees are north of Interstate 40, the best time to apply a Lorsban 4E trunk spray to protect the trees before borers enter is late May to early June; south of Interstate 40, mid-May to late May. This may vary by year, so pheromone trap counts will assist in timing this application. Lorsban 4E may only be applied once per year.

*Arkansas Is
Our Campus*

Visit our web site at:
<https://www.uaex.uada.edu>

Spray all young, non-bearing tree trunks again in August after the first catch of male moths with Endosulfan or Asana to keep trunks well covered with insecticide.

Insecticide to Use

Use Lorsban, Endosulfan 3EC or Asana XL on trunks. Spray should be mixed as follows: for a power sprayer, use 2 to 3.33 quarts of Endosulfan 3EC per 100 gallons of water.

Lorsban 4E should be used at the rate of 3 quarts per 100 gallons of water. Do not allow these sprays to contact leaves or fruit because of residue regulations. Asana XL EC can be used at the rate of 2 to 5.8 ounces per 100 gallons of water.

Application

A dilute spray of 100 gallons per acre is recommended. If this precaution is followed, limitations established by USDA will not be exceeded.

Most peach growers probably prefer to use a power sprayer for trunk spraying. However, the guns or booms normally used with this equipment have several drawbacks. It is impossible to get thorough coverage of the trunk without considerable runoff and waste of spray even when low pressure is used. It is practically impossible to prevent contamination of low-hanging fruit with the spray material. This is especially important on early-ripening varieties. Also, spraying a tree takes longer than is desired.

These difficulties can be eliminated by using a rod especially suited for trunk spraying. (See Figure 1.) The rod is simple to make and is relatively inexpensive. One unit requires three nozzles, 12 feet of 1/8-inch galvanized pipe and fittings, a cutoff valve and adapters for fitting to the spray hose.

The rod should be about 7 feet long to allow the operator to stay far enough away from the tree to prevent interference by the branches. Arrange the nozzles so that the spray is directed toward the tree from three different angles. The operator can allow the spray machine to carry practically all the weight of the spray hose. As you near the tree, place the other end of the rod on the ground and push it into position around the base of the tree. Open the valve. Walk past the tree while it is being sprayed. It is unnecessary to lift the end of the rod from the ground since the nozzles are set to cover the tree to the desired height. Only 2 1/2 to 3 seconds are required to spray one tree.

Hoe the area around the tree and level the ground prior to spraying. This is desirable regardless of the type of spray equipment being used.

Clean gum from trees now infested with borers by applying plain water with a power sprayer operating at 400 to 600 pounds pressure per square inch. This plain water should be directed by means of a hand gun or similar equipment.

A crew of three men using a power sprayer and two of the rods described should be able to spray 80 to 100 acres of peach orchard in a day without difficulty.

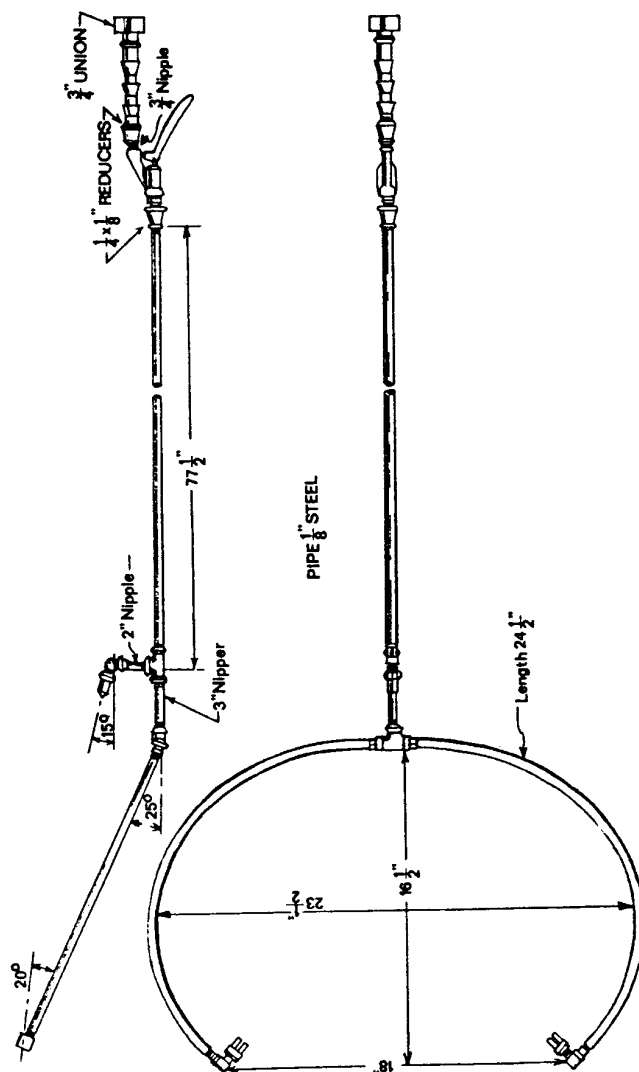

Figure 1. Special Rod for Trunk Spraying

DR. GLENN E. STUDEBAKER is assistant professor and Extension entomologist, Northeast Research and Extension Center, Keiser, and **DR. JOHN HOPKINS** is assistant professor and Extension entomologist, Little Rock. Both are with the University of Arkansas Division of Agriculture, Cooperative Extension Service. **DR. DONN T. JOHNSON** is entomology professor, University of Arkansas, Fayetteville campus.

FSA7504-PD-11-05RV

Issued in furtherance of Cooperative Extension work, Acts of May 8 and June 30, 1914, in cooperation with the U.S. Department of Agriculture, Director, Cooperative Extension Service, University of Arkansas. The Arkansas Cooperative Extension Service offers its programs to all eligible persons regardless of race, color, national origin, religion, gender, age, disability, marital or veteran status, or any other legally protected status, and is an Equal Opportunity Employer.