

# General Fumigation

Classification 3

## Training Manual



UNIVERSITY OF ARKANSAS

DIVISION OF AGRICULTURE

Cooperative Extension Service

**Edited by:**

Dr. Donald R. Johnson, Professor Emeritus and Extension Entomologist (Retired),  
Professor Emeritus, University of Arkansas Division of Agriculture, Cooperative  
Extension Service

Dr. John D. Hopkins, Professor and Extension Entomologist, University of  
Arkansas Division of Agriculture, Cooperative Extension Service

## Preface

This manual provides information for the Arkansas commercial pesticide applicator wishing to become certified in General Fumigation – Classification 3. To become a certified applicator in this category, a candidate must pass both a general standards exam and an examination based primarily on the material presented in this manual and (Circular 6) Arkansas Pest Control Law (act 488 of 1975, as amended). Information covered in the general standards examination is contained in “A Guide for Private and Commercial Applicators: Applying Pesticides Correctly.” Refer to (Circular 6) Arkansas Pest Control Law (act 488 of 1975, as amended) for specific requirements. The Arkansas State Plant Board administers the examinations. Up-to-date study materials can be obtained from the Arkansas State Plant Board, #1 Natural Resources Drive (P.O. Box 1069), Little Rock, AR 72203-1069, phone (501) 225-1598. Additional study information may be obtained from the University of Arkansas Cooperative Extension Service, the pesticide label, current publications on the subject, pesticide distributors, and manufacturers.

## Acknowledgments

Information accumulates from direct observations, scientific literature, and anecdotes from others. Information from these sources blurs together quickly, and consequently, unique ideas are rare in society. Credit for sources of information on urban pest control and management must go to:

Land Grant University extension and research workers, most entomologists, who pioneered this work, those who kept training and research alive during the period when the success of synthetic organic pesticides preempted nearly all but control evaluations from the 1940s to the 1960s, and those who persist today; pest control industry workers who held training sessions nationally, regionally, and locally where information was disseminated among the experienced and provided to the inexperienced; Environmental Protection Agency personnel who molded modern training and influenced the need for national uniformity in training requirements; state regulatory personnel who cooperated with universities and industry and who strongly emphasized the importance of training; and the few textbook authors in the United States and England who compiled the reference data in the understandable and usable form that allows urban pest management practitioners to be professionals.

This manual has been adapted from commercial applicator certification training manuals for “Fumigation” and “Fumigation of Soil and Agricultural Products” primarily developed by the **Virginia Cooperative Extension, Virginia Polytechnic Institute and State University**, with information also from Oklahoma Cooperative Extension Service, Division of Agricultural Sciences and Natural Resources, Oklahoma State University; and University of Nebraska Cooperative Extension, University of Nebraska-Lincoln.

# Table of Contents

	Page No.		Page No.
<b>Unit 1. Introduction</b> .....	7	<b>Unit 3. Characteristics and Effects of Fumigants</b> .....	53
Learning Objectives .....	7	Learning Objectives .....	53
Terms to Know .....	7	Terms to Know .....	53
What Is a Fumigant? .....	7	Characteristics of Fumigants .....	54
Scope of This Manual .....	8	Factors That Affect Fumigation of Raw Agricultural Products .....	57
The Fumigation Manual .....	8	Factors That Affect Soil Fumigation .....	61
Integrated Pest Management (IPM) and Decision-Making .....	9		
<b>Unit 2. Pest Identification, Biology and Management</b> .....	12	<b>Unit 4. Pest Management Options</b> .....	66
Learning Objectives .....	12	Learning Objectives .....	66
Terms to Know .....	12	Terms to Know .....	66
Who “Dunnit”? .....	14	IPM and Decision Making .....	67
Pests of Stored Products .....	14	Pathogens and Pests in Soil .....	77
Pests of Raw Agricultural Products .....	16		
Common Pest Descriptions .....	17	<b>Unit 5. Methods of Fumigation</b> .....	81
Moth Pests .....	17	Learning Objectives .....	81
Beetle Pests .....	21	Terms to Know .....	81
Other Pests .....	27	Fumigation Methods .....	82
Pests of Wood .....	30	Vault Fumigation .....	83
Termites .....	30	Tarpaulin Fumigation .....	88
Beetles .....	32	Spot (Local) Fumigation .....	91
Miscellaneous Pests .....	35	Aeration After Fumigation .....	92
Bed Bugs .....	35	Factors Affecting Aeration Time .....	92
Cockroaches .....	35	Aeration Procedures .....	93
Rodents .....	38	Fumigation Methods – Soil .....	97
Pathogens and Pests in Soil .....	40	Fumigant Movement Through Soil .....	97
Nematode Pests .....	40	Formulations of Soil Fumigants .....	97
Plant Diseases .....	41	Application and Containment of Soil Fumigants .....	97
Weeds .....	43	Methods of Soil Fumigation .....	98
Insect Pests .....	44	Soil Aeration .....	100
Monitoring and Sampling in Raw Agricultural Products and Soil .....	48	Factors Affecting Soil Aeration .....	101
Detecting Pest Problems – Raw Products .....	48		
Detecting Pest Problems – Soil .....	49		

	<b>Page No.</b>
Equipment Calibration .....	102
Useful Information for Calibration .....	102
Equipment Calibration – Soil Injection .....	102
Equipment Calibration – Chemigation .....	105
Test Your Knowledge .....	107

**Unit 6. Public, Personal and Environmental Safety** .....110

Learning Objectives .....	110
Terms to Know .....	110
Protecting the Public and the Environment .....	111
Read the Label Information .....	111
Signage for Fumigated Areas .....	112
Monitoring for the Fumigant .....	112
Transporting Fumigants .....	112
Storage and Disposal of Fumigants .....	113
Tolerance Levels .....	113
Proper Aeration .....	113
Preparation and Planning .....	113
Personal Safety .....	113
First Aid for Fumigant Poisoning .....	119
Test Your Knowledge .....	122

**Unit 7. Safety Equipment** .....124

Learning Objectives .....	124
Terms to Know .....	124
Respiratory Equipment Protection .....	124
Atmosphere-Supplying Respirators .....	125

	<b>Page No.</b>
Self-Contained Breathing Apparatus (SCBA) .....	125
Supplied-Air Respirators (SAR) .....	125
Air-Purifying Respirators .....	126
Care of Respiratory Protection Equipment .....	127
Fitting and Testing the Respirator .....	127
Use of Respiratory Protection Equipment .....	128
Gas Detection Equipment .....	129
Other Protection Equipment .....	131

**Unit 8. Common Fumigants** .....134

Learning Objectives .....	134
Terms to Know .....	134
Common Fumigants .....	135
Disclaimer .....	135
Sulfuryl Fluoride .....	135
1,3-Dichloropropene .....	137
Chloropicrin .....	139
Controlled Atmospheres (CAs) .....	141
Carbon Dioxide .....	141
Dazomet .....	143
Metam Sodium .....	144
Methyl Bromide .....	147
Phosphine .....	151

**Appendix A.  
Sample Safety Checklists** .....158

**Appendix B.  
Volume Calculations** .....169

The pesticide information presented in this publication was current with federal and state regulations at the time of printing. The user is responsible for determining that the intended use is consistent with the label of the product being used. Use pesticides safely. Read and follow label directions. The information given herein is for educational purposes only. Reference to commercial products or trade names is made with the understanding that no discrimination is intended and no endorsement by the Cooperative Extension Service is implied.

# Unit 1. Introduction

## Learning Objectives

After reading this unit, the reader will be able to:

- Explain what fumigants are and how they work.
- Understand the scope of this manual.
- Summarize the contents of this manual.

The introduction describes the importance of fumigation. Although they are highly toxic, fumigants are often the best and only way to control pests in soil and raw commodities. They are also important for quarantine between states and between countries. By reading this unit, you will learn what fumigants are and how they work. This unit will outline the scope and purpose of this manual. It will also describe each unit and the type of information included.

## Terms to Know

**Aeration** – The process of replacing fumigant-containing air or water with fresh air and/or water that contains little or no fumigant. Aeration must follow all fumigation operations.

**Commodities** – Items produced for trade or commerce.

**Fumigant** – A pesticide that is a gas, or forms a gas, when applied. In a high enough concentration, this gas (vapor) has pesticidal action.

**Infestation** – A pest population that grows so large it becomes harmful or unpleasant.

**Integrated Pest Management** – A pest management system that uses all appropriate strategies to reduce pest populations.

**Molecules** – The smallest particle of a substance that retains all the properties of that substance.

**Pest** – Any living thing that is undesirable or causes harm to people or the environment. An organism may be a pest in one place but not in another; for example, termites in a house vs. those that recycle dead trees in a forest.

**Tilth** – The physical condition of soil that determines the ease with which it can be tilled or cultivated and its suitability for seed germination and plant growth.

The earliest use of fumigants as pesticides dates back to 2500 BC. At that time, people burned sulfur to control insects and mites. Today, we use fumigants to control insects, rodents and other pests. We rely on these chemicals to treat grain bins, boxcars and even soil. Fumigation is one of the quickest and most effective ways to eliminate pests from stored grain, tobacco and sometimes homes. We also use fumigation in quarantine. It helps to prevent pests from traveling from one location to another.

Unfortunately, fumigants are some of the most toxic pesticides in the world. Even small amounts can kill nontarget insects, animals and people. Fumigants are often fast acting, odorless and invisible. Many are highly flammable. For these reasons, fumigators require more training and skill than do many other pest control operators. Skill and training are critical for safe application.

## What Is a Fumigant?

A fumigant is a gas with pesticidal action. Fumigants are gases, or form gases, after application. In a high enough concentration, a fumigant can kill insects and other pests. Fumigants may be odorless, and usually cannot be seen.

People often mistake smokes, fogs, mists and other aerosols for fumigants. However, these pesticides produce relatively large particles or droplets that are very different from fumigants. They are not true fumigants because they are not gases.

As a gas, a fumigant consists of separate molecules that are much smaller than the droplets of a fog or mist. Fumigants can penetrate even seemingly solid items like brick, concrete and wood. However, these items are not as solid as they appear. In a magnified view, it is

possible to see the molecules of wood and the spaces between them. Fumigant molecules actually move between the wood molecules to reach the pests. Because fumigants penetrate so well, they must be confined in an enclosed space. As soon as a fumigant escapes from an enclosure, its effectiveness is lost.

*NOTE: Fumigants provide no residual protection. Once a commodity has been treated and aerated, new pests can attack at any time.*

## Scope of This Manual

Fumigation is used to treat a wide range of pests in many locations. It is most often reserved for pests that live in hard-to-reach areas such as soil, stored grain or wood.

This manual, General Fumigation, covers fumigation of structures, soil and agricultural sites, such as crop fields, that are used for the production of agricultural products. It also deals with the fumigation of food and raw commodities. Raw commodities include whole grains, tobacco, nuts, raw logs and other unprocessed products.

## The Fumigation Manual

The purpose of this manual is to provide basic information to help you fumigate safely and effectively. It starts by describing the major (the most common and the most damaging) pests of structures, soil, food and raw commodities in Arkansas. While the list is long, it is by no means complete. Professional organizations, universities, industries and government agencies produce detailed field guides and other pest identification references. These sources will help you learn more about the pests described here. They will also describe pests not included in this manual.

Many things can be pests. Insects, mites, nematodes, pathogens and rodents can all harm structures, soil-grown crops and stored commodities. This manual will focus on pests that are commonly controlled by fumigation. You will learn about their life cycles and what to look for when scouting. This manual also describes the most vulnerable stage (s) of common pests and the best time(s) for efficient and effective control.

You will also learn about fumigants. Fumigants have many characteristics that can affect how well they work. These include boiling point, molecular weight, water solubility and flammability. External factors such as temperature and humidity can also affect performance. When fumigating soil, application techniques and soil features such as tillage and texture can affect the success of your treatment. This manual will describe these factors and help you understand how different fumigants will perform in different situations.

This manual describes the principles of Integrated Pest Management (IPM). It explains when and how fumigation fits into a well-planned IPM program. You will also learn several ways to control pest and disease problems without fumigation. These alternatives to fumigation may be cultural, biological or chemical. By using a combination of methods, you may often achieve the best control.

This manual will introduce you to a range of fumigation methods and equipment. You will learn basic techniques used to treat soil and raw commodities. Each method has its pros and cons. You will learn how to select a treatment method based on the pest, the item or type of soil infested and the severity of the infestation. During fumigation, problems often arise. You will learn how to prevent these problems, and how to handle them if they do develop.

Aeration must follow all types of fumigation. For indoor treatments, aeration introduces fresh air to dilute and remove fumigant-filled air. For soil treatments, aeration allows the fumigant to escape from the soil and/or water in the soil, until little or no fumigant is left. Proper aeration is key to safe fumigation. Procedures for aeration vary with the fumigant, the item or type of soil treated and the conditions in the treatment area. This manual will describe aeration techniques for a variety of situations.

Pest control decision-making will be addressed throughout this manual. Before fumigating, answer the following questions:

- Is the problem actually caused by a pest?
- If so, what pest?
- What effective and affordable control options are available?

- Is the problem severe enough to warrant fumigation?
- Is the pest in a vulnerable stage in its life cycle?

A good planner makes careful records of pest problems: when and where the problem occurred, solutions and results. He or she also learns how to prevent future problems.

Fumigants are the most hazardous of all pesticides. Small amounts of many fumigants can cause serious illness or death. This manual describes ways to protect the public, your co-workers and yourself from exposure. It provides safety checklists for all stages of fumigation. You will learn about special tools and first aid techniques.

Respirators and gas detectors are two of the most important safety tools in fumigation. Respirators provide clean air to workers during fumigation and aeration. Gas detectors monitor and record gas levels before, during and after treatment. This manual will describe several models of each device. You will learn how to select the best model for your situation. You will also learn how to inspect, maintain and use this equipment properly.

Finally, this manual will discuss common fumigants used to treat structures, soil, food products and raw commodities.

## Integrated Pest Management (IPM) and Decision-Making

There are many ways to control pests that infest structures, wood and stored products. Your job is to select the best method for the situation at hand. Pesticides and other control methods often provide good to excellent control temporarily. However, if you want consistent, reliable, long-term control, you need Integrated Pest Management (IPM).

IPM is an ecological approach to pest control. It is based on the habitat and life cycle of the pest. It combines all of the most appropriate pest control strategies into a unified, site-specific plan. IPM plans may include both nonchemical and

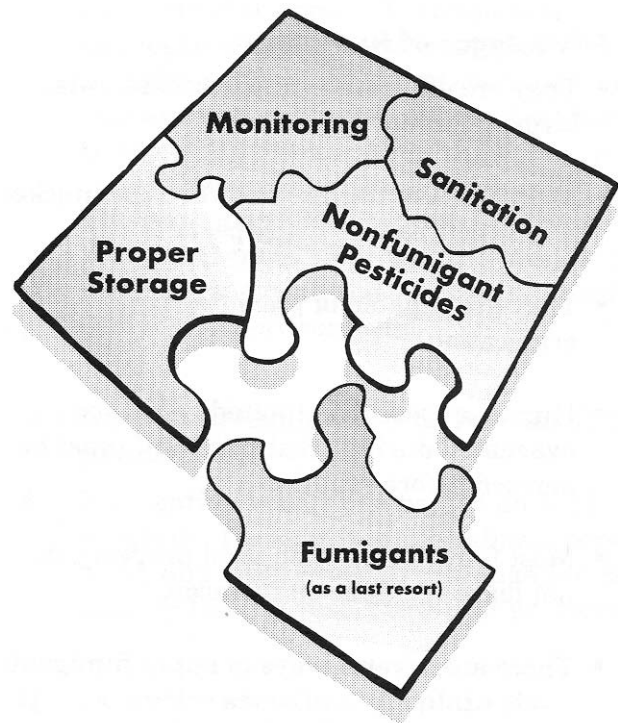

chemical management methods. IPM is dedicated to removing causes rather than simply treating symptoms. The goals of an IPM program are to reduce pest numbers to an acceptable level in a way that is practical, cost-effective and safe for people and the environment.

The first strategy of an IPM program is prevention. Prevention relies on sanitation, proper storage and the condition of the commodity before and after it is placed into storage. You may be able to exclude pests or provide them with unsuitable living conditions. Preventing a pest problem before it occurs saves time and money.

IPM also relies on scouting and sampling. Scouting and sampling will help you determine if treatment is needed and/or if previous control measures were effective. Check structures and commodity storage areas regularly. Look for signs of new infestations. Sample commodities to check their physical condition. Determine what pests are present, how many of each kind are in the area and how much damage they are causing.

When an infestation does occur, identify the pest. Learn how it causes damage and when it is most vulnerable. Then, develop a control plan. Consider all appropriate control options. Your strategy should be economical and safe for the



environment. Follow-up site inspections are critical. Did the control tactic work? Is retreatment needed? Continue to monitor areas for long-term control.

Fumigation is only one option of an IPM program. Because it is specialized, very toxic and often expensive, fumigation should be the last resort to a pest problem. When deciding whether to fumigate, weigh these advantages and disadvantages.

## Advantages of Fumigants

- They are effective against insects, rats, birds, mammals and fungi.
- Most are fast acting. They are the quickest way of controlling many pests.
- They are capable of providing total eradication.
- Human exposure is limited. Areas are evacuated during treatment and must be aerated before reentry.
- Most fumigants, when used properly, do not leave residues on surfaces.
- There are several ways to apply fumigants.
- They penetrate and treat cracks, crevices, burrows, partitions, commodities and equipment that cannot otherwise be reached.
- You can apply them without disturbing the commodity.
- They are usually readily available.
- You can use some fumigants in or near food without leaving harmful residues, tastes or odors.

## Disadvantages of Fumigants

- They are highly toxic to most living things, including humans. Breathing even small amounts of some fumigants can be fatal.
- They require special protective equipment, such as a Self-Contained Breathing Apparatus (SCBA) and gas detectors.
- They require highly trained applicators.
- They offer no residual control. Once an area or item is aerated, traces of fumigant do not remain to help control future pests.
- They must be confined in a tightly sealed area to be effective.
- Some may injure seeds and reduce germination. Others may leave toxic residues, tastes or odors.
- Because they are fast acting, response to problems and emergencies must be quick. Spills, leaks and equipment failures usually call for immediate action.
- They often require warm temperatures to be effective. Temperature requirements may be hard to meet, especially in the winter.
- Some are expensive.
- Some are corrosive.
- They usually require a special license(s) or permit(s). This is because most are classified as restricted-use. Only properly certified applicators can purchase and use restricted-use pesticides.
- Some fumigants are hard to remove from fumigated material (ex. methyl bromide).

# Test Your Knowledge

## Q. What is Integrated Pest Management (IPM)?

- A. IPM is an ecological approach to pest control. It is based on the habitat and life cycle of the pest. It combines all appropriate pest control strategies, including nonchemical and chemical management methods. IPM is dedicated to removing causes rather than simply treating symptoms. Prevention is key. The goal of an IPM program is to reduce pest numbers to an acceptable level in a way that is practical, cost effective and safe for the environment.

## Q. How does fumigation fit into an IPM program?

- A. Fumigation is only one part of an IPM program. Because it is specialized, very toxic and often expensive, fumigation is usually the last resort to a pest problem.

## Q. Describe scouting. Explain its importance in effective pest management.

- A. Scouting is checking or monitoring for pests in an area to determine what pests are present, how many of each kind are in the area and how much damage they are causing. Scouting will help you determine if treatment is needed and/or if previous control measures were effective.

## Q. List some of the advantages of fumigants.

- A. They are effective against insects, rats, birds, mammals and fungi.
- Most are fast acting.
  - They are capable of providing total eradication.
  - Human exposure is limited.
  - Most fumigants, when used properly, do not leave residues on surfaces.
  - There are several ways to apply fumigants.
  - They penetrate and treat hard-to-reach areas.
  - You can apply them without disturbing the commodity.
  - They are usually readily available.
  - You can use some fumigants in or near food without leaving harmful residues, tastes or odors.

## Q. List some problems with fumigants.

- A. They are highly toxic to most living things, including humans.
- They require special protective equipment.
  - They require highly trained applicators.
  - They offer no residual control.
  - They must be confined in a tightly sealed area to be effective.
  - Some may injure seeds and reduce germination. Others may leave toxic residues, tastes or odors.
  - Response to problems and emergencies must be quick.
  - Temperature requirements may be hard to meet.
  - Some are expensive.
  - Some are corrosive.
  - They usually require a special license(s) or permit(s).
  - Some fumigants are hard to remove from fumigated material.

## Q. In what situations are fumigants commonly used?

- A. We rely on fumigants to treat structures, grain bins, boxcars and soil. Fumigation is one of the quickest and most effective ways to eliminate pests from stored grain, tobacco and sometimes in quarantine. It helps to prevent pests from traveling from one location to another.

## Q. What is a fumigant?

- A. A fumigant is a pesticide that is a gas, or forms a gas, when applied. In a high enough concentration, this gas (vapor) has pesticidal action.

## Q. How does being a gas contribute to a fumigant's effectiveness?

- A. As a gas, a fumigant consists of separate molecules that are much smaller than the droplets of a fog or mist. Fumigants can move into tiny gaps, such as between kernels of grain, or through small spaces in soil. Fumigants can penetrate even seemingly solid items like brick, concrete and wood.

# Unit 2. Pest Identification, Biology and Management

## Learning Objectives

For each pest described in this unit, the reader will be able to:

- Identify it by appearance, habits and types of damage.
- Describe its preferred habitat.
- Understand its behavior and life cycle.
- Recognize conditions favorable to pest problems.
- Discuss prevention and control methods.

This unit describes Arkansas' most common pests of raw and processed commodities, wood (structural and unfinished wood products), and pests in soil that are controlled with fumigants. By reading it, you will learn why these organisms are considered pests. You will also learn what these pests look like and where they live. Proper identification of pests is essential to choosing the most effective control method. This unit will also describe techniques used to prevent or control infestations.

Universities, government agencies, industry and other organizations produce detailed field guides and other useful references. These sources will help you to learn more about the common pests described here. In addition, they may describe additional pests not included in this unit.

*NOTE: Every living thing has a scientific name and a common name. Since it does not change, Latin is the language that scientists use to name living things. Scientific (Latin) names are the same throughout the world. On the other hand, common names may vary across the country, sometimes even within a state or county. Sometimes people may refer to two different things by the same common name. When you discuss a pest problem with another person, make sure you are both referring to the same pest. Use scientific names whenever possible. This unit gives the common and the scientific (Latin) name for the insects described. Scientific names are in italics and placed in parentheses. The first name is the "genus." The second name is the "species." The term "spp" indicates that there are several species within a single genus.*

## Terms to Know

**Abdomen** – The hindmost or rear body section of an insect.

**Antennae** – A pair of jointed appendages on the head of an arthropod. Antennae are usually long and slender. They are used to sense things in the arthropod's environment.

**Arachnid** – A wingless arthropod with the body divided into two parts. Arachnids have four pairs of legs on the rear body section. They do not have antennae. Mites, spiders and ticks are arachnids.

**Arthropod** – A animal with jointed legs and a segmented, jointed exoskeleton. Beetles, wasps, crayfish and spiders are arthropods.

**Caterpillar** – The larval stage of a butterfly or moth.

**Cocoon** – An envelope formed by an insect larva, in which it spends the pupal state.

**Colony** – A family group of social insects. Social insects, like ants and termites, live together in large groups called colonies. Usually, individuals in a colony "specialize." Different jobs include finding food, taking care of the young, building and repairing the nest and laying eggs.

**Contact Pesticide** – A chemical that causes a localized injury where it touches a pest. Contact pesticides do not need to be ingested by the pest to cause toxic effects.

**Crop History** – Background information about a particular field including the dates and types of:

- Crops that were grown
- Pesticides that were applied
- Fertilizers that were applied
- Tillage and cultivation practices that were performed

**Dripline** – The line created by liquid dripping off of the outermost foliage of a plant to the ground after rain or another liquid has been applied.

**Egg Case** – A capsule containing eggs.

**Forewings** – The pair of wings closest to the head of an insect.

**Frass** – The waste product of insects. Frass can be muddy, powdery or palletized. The type of frass found on or in infested items can be useful in pest identification.

**Galleries** – Areas excavated in wood by termites, ants and the larvae of various beetles.

**Germinal** – At an early stage of growth. The germ, embryo or nucleus of a grain kernel.

**Grain Elevator** – A facility for holding stored grain before shipment.

**Grub** – The larval stage of some beetles.

**Habitat** – A specific area or environment in which an animal normally lives.

**Hard-seeded Weed** – A weed that produces seeds with waterproof seed coats.

**Herbicide** – A pesticide that kills or inhibits the growth of undesirable plants.

**Hind Wings** – The pair of wings closest to the rear of an insect.

**Host** – An organism with a parasite living in or on it. The parasite obtains part or all of its nourishment from the host.

**Infest** – To inhabit or overrun in large numbers.

**Infestation** – A pest population so large that it is harmful or unpleasant.

**Insect** – An arthropod with a body divided into three regions: head (front), thorax (middle) and abdomen (rear). Insects have three pairs of legs on the thorax. Usually, adult insects have one pair of antenna and two pairs of wings. Ants, cockroaches, beetles and flies are insects.

**Instar** – In insect development, a stage between successive molts. For example, the first instar is between hatching and the first molt.

**Juvenile Nematode** – An immature nematode. Juvenile nematodes are also sometimes called larvae.

**Larva (Plural = Larvae)** – An immature stage in the life cycle of an insect with complete metamorphosis. Most insect larvae look like segmented worms with legs. As a rule, the larval

stage is an active, feeding stage. Maggots (flies) and caterpillars (butterflies and moths) are insect larvae. In complete metamorphosis, the larval stage is between the egg and the pupa stage. Larva is also sometimes used to refer to a juvenile nematode.

**Larva (Larvae = Plural)** – An immature stage in the life cycle of an insect with complete metamorphosis. Most larvae look like segmented worms with legs. As a rule, the larval stage is an active, feeding stage. Maggots (flies) and caterpillars (butterflies and moths) are insect larvae. In complete metamorphosis, the larval stage is between the egg and the pupa stage.

**Life Cycle** – The stages of development. The continuous sequence of changes that an organism undergoes during its life.

**Mandibles** – The jaws used by some insects to bite and/or chew.

**Metamorphosis** – The change in body form during the life cycle. Some organisms are born looking like small adults. Others change considerably in appearance (in stages) as they develop. Most insects go through some sort of metamorphosis in their life cycle.

**Complete Metamorphosis** – Insect development involving four different body forms and life stages. A good example of complete metamorphosis is the life cycle of a butterfly or moth. A butterfly life cycle starts with an egg. An active feeding stage called a larva hatches from the egg. A butterfly larva is called a caterpillar. When caterpillars get to a certain size and age, they make a protective case. The next stage, which is called a pupa, does not feed. Inside the case, the pupa changes into an adult.

**Gradual Metamorphosis** – Insect development in three stages. In gradual metamorphosis, the egg hatches into a nymph. A nymph is a small, immature stage resembling the adult in body form. As the nymph grows, it develops wings and functional reproductive organs. Grasshoppers and cockroaches go through gradual metamorphosis.

**Molt** – To shed. Arthropods shed their exoskeleton when they molt.

**Nematicide** – A chemical or physical agent that kills or inhibits nematodes.

**Nymph** – The developmental stage of an insect with gradual metamorphosis. Nymphs hatch

from eggs and gradually develop into mature adults.

**Pathogen** – An organism that causes disease in other organisms (“hosts”).

**Pheromone** – A chemical released by an organism that influences the behavior of other organisms of the same species. Pheromones are often used in traps to attract insects to a specific location.

**Pronotum** – A shieldlike top plate on the front of the thorax. In some insects, like the cockroach, the pronotum covers the head.

**Pupa (Plural = Pupae)** – In complete metamorphosis, the stage of development between the larva and adult. Pupae do not feed. Usually, they are not mobile.

**Residual Pesticide** – A pesticide that persists and remains toxic after it is applied. Residual pesticides can kill pests over a period of time.

**Sapwood** – The young, living wood tissue that lies in the outer perimeter of a tree trunk or branch.

**Softwood** – A tree that usually has needlelike leaves and produces its seeds in a conelike structure. Examples include pines, spruces and firs.

**Sign** – The visible parts or products of a disease-causing organism. Examples include fungal spores or mycelia or ooze from bacterial cankers.

**Soil-Borne Pathogen** – A disease-causing organism that lives in soil. Soil-borne pathogens generally infect the roots and lower stems of plants but not the leaves or upper stems.

**Solid-seeded Crop** – A crop seeded so closely together that the plants appear to grow in a large group rather than in rows.

**Symptom** – A visible reaction by a host plant to the presence of a pathogen or other health problems.

**Thorax** – The middle segment of an insect’s body. The thorax lies between the head and the abdomen.

**Waiting Period** – The time you must wait between soil fumigation and planting or seeding a crop in order to avoid injury to the crop of the fumigant.

## Who “Dunnit”?

### Pests of Stored Products

Every living thing has a scientific name and a common name. Since it does not change, Latin is the language that scientists use to name living things. Scientific (Latin) names are the same throughout the world. On the other hand, common names may vary across the country, and sometimes even within a state or county. Sometimes people may refer to two different things by the same common name. When you discuss a pest problem with another person, make sure you are both referring to the same pest. Use scientific names whenever possible. This unit gives the common and the scientific (Latin) name for the insects described. Scientific names are in italics and placed in parenthesis. The first name is the “genus.” The second name is the “species.” The term “spp” indicates that there are several species within a single genus.

Nonagricultural fumigation is most often used to manage insect pests. Insects can cause problems just about everywhere. You can find them in:

- Homes
- Apartments
- Public buildings
- Rest homes
- Nursing homes
- Hospitals
- Schools
- Food processing plants
- Storage facilities
- Businesses
- Anywhere people live and work

Many insects enter buildings by accident or for shelter. Others live in buildings year-round. While all insects can be nuisances, only a few cause serious damage. Fumigation is reserved for only the most damaging insect pests and pest situations.

Each type of insect pest has a set of characteristics that can be used to identify it. This “profile” includes appearance, preferred habitat or food, signs of damage, seasonal life cycle and periods of activity. Insects also look different and/or have different body forms during their life. It is important to recognize the profile for an insect pest during each stage of its life.

Often, successful pest management depends on early diagnosis. Since many insect pests are small and hard to see, it is important to look for signs of damage. Effective diagnosis of an infestation depends on several factors:

- Recognition of damage
- Accurate identification of what is causing the problem
- Knowledge of the pest's life cycle and habits
- An assessment of the distribution, density, and dynamics of the pest population

Regular and careful monitoring will detect early warning signs of pest activity. A well-trained pest manager can match symptoms with a probable cause. Close examination will usually find the pest. Knowing the pest's biology will help you decide when and how to manage it effectively and economically. Finally, you will need to study the pest population to decide if fumigation is necessary. You will need to know at least three things:

1. How large is the pest population?
2. How are the pests in the population distributed (for example, randomly or in clusters)?
3. Is the population increasing or decreasing in size?

This unit describes some of the most common pests of stored products and wood. Each section includes a description of the pest, its life cycle, habitat preferences and the damage it causes. While the list of pests is long, it is by no means complete. For information about pests not included in this manual, consult your local Extension office/agent.

This unit also describes prevention and control options (chemical and nonchemical) for each pest. When chemical control is necessary, baits and nonfumigant pesticides should be your first line of attack.

*NOTE: Structural fumigation is not effective against insects that build their nests or galleries outside a structure. For example, as a rule, fumigants will not control subterranean termites or carpenter ants. Subterranean termites usually nest underground. Carpenter ants usually form their parent colony outside a structure. While a fumigant will kill the insects within the structure, the underground and outdoor nests will remain unharmed. In time, reinfestation*

*may occur. To control such insects, you must use nonfumigant pesticides (baits, sprays, etc.). For this reason, only insects that build their nest within a structure are included in this manual.*

Insects cause vast losses of stored products worldwide. Stored products include:

- Fabrics
- Rugs and carpeting
- Paper products
- Milled or ground food such as flour, meal, cereals, cake mixes and pet food
- Nuts and dried fruits
- Meats and other animal products such as wool, fur and angora
- Spices, coffee and tea

The type of damage caused varies with the insect and the stored product. Some insects stain and severely damage fabrics and hard goods. Others consume large amounts of stored food, reducing the amount for sale. Still other pests make fresh and stored food products inedible and unmarketable. In all cases, stored-product pests can cause significant financial losses.

Common pests of stored products include moths, beetles and cockroaches. These pests can be controlled with fumigant pesticides in some situations.

The most common moths found in non-agricultural areas that are a pest for stored products include:

- Indianmeal moth
- Webbing moth

The most common beetles found in non-agricultural areas that are a pest for stored products include:

- Rice weevil
- Granary weevil
- Cigarette beetle
- Drugstore beetle
- Confused flour beetle
- Red flour beetle
- Sawtoothed grain beetle
- Merchant grain beetle
- Larder beetle

Other pests:

- Cockroaches
- Rodents

# Pests of Raw Agricultural Products

A wide range of pests infest soil and agricultural products. Insects, mites, nematodes, diseases and rodents can all harm soil-grown crops and stored commodities. This manual will focus on pests that are commonly controlled by fumigation.

Determining the type of pest causing damage is often difficult. Many are small and hard to see. Others hide in cracks, crevices or within grain kernels themselves. In the field, pests hide in the soil and in the roots and stems of plants. With no suspect present, your only clue may be the damage itself. Often the damage from one pest can be distinguished from that of another pest. To manage a pest effectively, you must be able to identify it. You must also understand its life cycle and environmental requirements. Treatment of an unidentified pest can lead to poor results. You may also be in violation of state and federal pesticide laws. This unit will help you recognize the most common pests of soil and agricultural products.

Each pest has a set of characteristics that can be used to identify it. This “profile” includes appearance, preferred habitat and food, signs of damage, seasonal life cycle and periods of activity. Some pests look different and/or have different body forms during their life. It is important to recognize the “profile” for a pest during each stage of its life.

Often, successful pest management depends on early diagnosis. Since many pests controlled by fumigation are small and hard to see, it is important to look for signs of damage. Effective diagnosis of an infestation depends on several factors:

- Recognition of damage
- Accurate identification of what is causing the problem
- Knowledge of the pest’s life cycle and habits
- An assessment of the distribution, density and dynamics of the pest population.

Regular and careful monitoring will detect early warning signs of pest activity. A well-trained pest manager can match symptoms with a probable cause. Close examination will usually find the pest. Knowing the pest’s biology will help you decide when and how to manage it

effectively and economically. Finally, you will need to study the pest population to decide if fumigation is necessary. You will need to know at least three things:

1. How large is the pest population?
2. How are the pests in the population distributed (for example, randomly or in clusters)?
3. Is the population increasing or decreasing?

This unit describes some of the most common pests of soil and agricultural products. Each section includes a description of the pest, its life cycle, its habitat preferences and the damage it causes. Although the list of pests is long, it is by no means complete. For information about pests not included in this manual, consult your local Extension office/agent.

This unit also describes prevention and control options (chemical and nonchemical) for each pest. When chemical control is necessary, baits and nonfumigant pesticides should be your first line of attack.

## Locations to Find Pests of Raw Agricultural Products

Insects are the most common pests of raw agricultural products. Raw products include whole grains (corn, rice, wheat, etc.), cured tobacco, baled cotton, seeds and other unprocessed agricultural goods. They attack these commodities in:

- Grain elevators
- Silos
- Storage bins
- Barns
- Railroad cars
- Tractor trailers

Although most insects can be nuisances, only a few cause serious damage. Fumigation is reserved for the most damaging insect pests and pest situations.

## Primary Feeders vs. Secondary Feeders of Stored Grain

Insect pests of stored agricultural products can be divided into two groups: primary and secondary feeders. The distinction is based on the feeding habits of the pest.

Primary feeders are capable of destroying whole, sound grain. The most damaging primary feeders are those that develop within grain kernels. These insects feed on the “germinal” region (early growth) of the seed, reducing its nutritional value and its ability to sprout. Damage caused by internal feeders also makes grain more susceptible to secondary feeders (insects that feed on grain debris). Adult females of internal feeders deposit eggs on or in whole kernels. Larvae develop within the kernels.

**Primary arthropod feeders include the:**

- Angoumois grain moth
- Rice, granary and maize weevils
- Lesser grain borer

Secondary feeders feed only on damaged grains and seeds. The outer layer of the grain or seed must be damaged – cracked, holed, abraded or broken. This may be caused by physical damage during harvesting, rapid drying or by the feeding of a primary feeder. Some secondary feeders live in grain storage areas with primary feeders. The grain trade generally refers to secondary-feeding beetles as “bran bugs” or “bran beetles.” Concentrations of bran beetles may raise the temperature and/or moisture level within stored grain. These conditions favor rapid population growth.

**The most common secondary feeders of raw agricultural products include the:**

- Indianmeal moth
- Mediterranean flour moth
- Tobacco moth
- Cadelle beetle
- Cigarette beetle
- Confused and red flour beetles
- Flat grain beetle
- Sawtoothed and merchant grain beetles
- Yellow mealworm beetle
- Grain mite

Both primary and secondary feeders can cause significant financial losses to growers of raw agricultural products. Common pests of raw agricultural products include moths, beetles, mites and rodents. You can control these pests with fumigant pesticides in some situations.

**Other pests of raw agricultural products include:**

- Rodents
- Rats
- Mice

## Common Pest Descriptions

### Moth Pests

Moths are second only to beetles in the amount of damage they cause to stored products. Thankfully, only the larval stage causes damage.

### Damage

Moth larvae damage grain by eating and contaminating it so that it is not fit for human consumption. Some moths like whole grains. Others prefer milled or ground foods such as flour, cereals and pet food. Damage usually occurs when these items are stored for an extended period. If control is poor, moths may follow a product throughout the manufacturing and distribution process. You can find moth pests in fields, storage bins, mills, delivery trucks, retail stores and consumers’ homes.

### Life Cycle

To control moths, you must understand their life cycle. Moths are close relatives of butterflies. They develop by complete metamorphosis. Female moths lay eggs singly or in small groups. An adult female can produce several hundred eggs during her brief life. The caterpillars hatch from the eggs and feed on nearby food. Each caterpillar grows and sheds its skin several times. After feeding for several weeks, the caterpillar spins a cocoon. In the cocoon, it transforms into a pupa. The adult moth emerges several weeks later. Adults live for a short time and do not feed on grains. Females die soon after they lay their eggs. Moths may produce several generations per year, depending on the temperature and food source. In good conditions (warm temperatures and abundant food), they may complete their life cycle in one to three months.

### Identification

Adult moths have two pairs of wings that fold over the body when the moth is resting. Like butterflies, some moths have color patterns on their wings. Others have solid-colored wings. The antennae of female moths are long and slender. The male’s antennae are long and brushlike or featherlike.



Moth larvae called caterpillars resemble small worms with legs. Some species have distinct color patterns that can help with identification. It is easy to confuse moth larvae with beetle larvae. An easy way to distinguish between the two is to look at the middle of their bodies. Moth larvae usually have fleshy, leglike appendages called “prolegs” on several of the middle segments of their bodies. Prolegs are not present on the middle sections of beetle larvae.

There are many types of pest moths. The following are some of the most common and troublesome to raw commodities in Arkansas.

**Angoumois Grain Moth**  
*Sitotroga cerealella*

Adults have four wings and about a 1/2-inch wingspan. The forewings are buff to pale yellowish brown. Hind wings are gray and pointed, resembling a pointed finger. Both sets of wings are fringed with long hairs. Adults are nonfeeding, short-lived and attracted to light. In the spring, they often fly out to fields and lay eggs on the grain kernels while they are still on the plant.

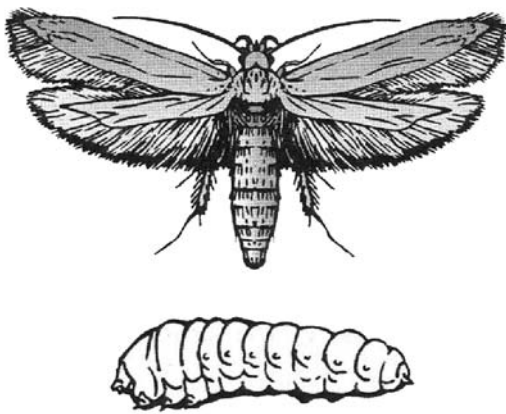

Angoumois grain moth adult and larva

Each female lays 40 to 400 eggs directly on grain kernels. The eggs are white when first deposited but soon turn red. Emerging larvae are white with yellowish heads and reddish brown mouthparts. Each larva bores into a whole grain kernel, spinning a silken web over the hole through which it enters. Once inside the kernel, larvae pupate inside the kernel. When they emerge, Angoumois grain moths leave a distinctive round flap over the hole in the grain.

Angoumois grain moths are primary feeders that attack only whole kernels or caked material.

Barley, rye, corn, oats, rice, wheat and various seeds are common targets. Larvae attack grain in the field as well as in storage. They cause a reduction in grain weight and quality. Heavily infested grain smells bad and is less attractive for consumption. Corn cribs infested with this insect will contain ears with small holes in individual kernels. Ears throughout the crib will be infested. In bins, however, only the top few inches of grain will be infested. The Angoumois grain moth prefers damp grain to dry grain. Adult moths cause no damage.

**Indianmeal Moth**  
*Plodia interpunctella*

Adult Indianmeal moths have four wings spanning about 3/4 inch. You can distinguish them from other moths by the color pattern of their front wings. The outer two-thirds of the front wings are reddish brown and the bases are grayish white. The hind wings are pale gray. The head and thorax are reddish. Adult Indianmeal moths are weak fliers. They are usually active for only a few hours in the evening. Most of the time, they remain close to the infested material.

Female adult Indianmeal moths lay from 100 to 400 eggs singly or in groups directly on food material. The small, pale yellow eggs hatch in about three days. Larvae emerge and feed on nearby grain products. They are usually dirty white but may have a greenish or pinkish tint. Full-grown caterpillars are about 1/2 inch long with a brown head. Caterpillars spin silk thread as they crawl. Heavily infested materials are often covered with a fine, weblike mesh of silk. Caterpillars usually move away from their food



Indianmeal moth adult and larva

to spin a cocoon and pupate. Sometimes you will find Indianmeal moth caterpillars crawling across ceilings or walls far from the source of infestation.

In agriculture, the Indianmeal moth is one of the most common pests of grain storage and processing facilities, as well as stored products in homes and warehouses. It is a secondary pest that feeds on cracked corn and grain that is damaged by other insects. It attacks grain and grain products, seeds, nuts, a variety of dried fruits and other commodities. Because of its preference for corn, the Indianmeal moth is common in the corn-growing and corn-storage areas of the United States. Adult Indianmeal moths cause no damage.

In stored products and around the home, Indianmeal moth larvae are one of the most common pests of stored flour products, ground meal, birdseed and dry pet food. They also feed on other dry foods including dried fruit, seeds, powdered milk, chocolate and candy. Adult Indianmeal moths cause no damage.

### **Mediterranean Flour Moth**

#### ***Ephestia kuehniella***

Adult moths are about 1/2 inch long with a wingspan of a little less than an inch. The forewings are pale gray with wavy black lines running across them. The hind wings are dirty white. When the adult is at rest, the head and abdomen are slightly raised, making the wings look as if they slope downward. Adults fly at night in a very characteristic zigzag pattern. Adults are also nonfeeding and short lived.

Adult females lay up to 675 white eggs on or near food. In three to five days, pinkish white larvae emerge. Larvae have reddish brown heads, a few small hairs and a few black spots on their bodies. They spin silken tubes within

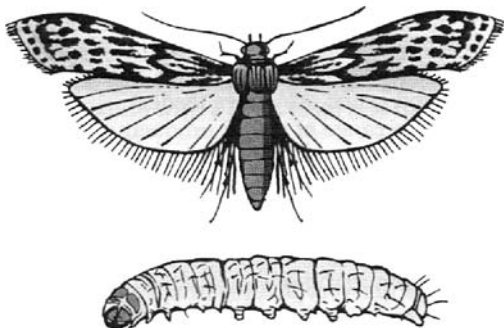

**Mediterranean flour moth adult and larva**

which they feed and mature. When fully developed, larvae are 1/2 to 2/3 inch long. Larvae are active crawlers. As they move, they spin silken threads that mat food particles together. These mats can clog processing equipment. Pupation occurs near clean food, away from large amounts of infested material.

The Mediterranean flour moth is a secondary feeder that prefers flour and meal. However, it also infests grain, nuts, seeds and other stored foods. Adult Mediterranean flour moths do not cause damage.

### **Tobacco Moth**

#### ***Ephestia elutella***

The tobacco moth is smaller than, but similar to, the Mediterranean flour moth. Adults are light grayish brown with two light-colored bands extending across each forewing. Its wingspan is about 5/8 inch. Black scales border the forewings. The hind wings are uniformly gray in color. Adults moths are nonfeeding and short-lived. They are attracted to lights at night and fly toward the top or roof of buildings at dawn and dusk.

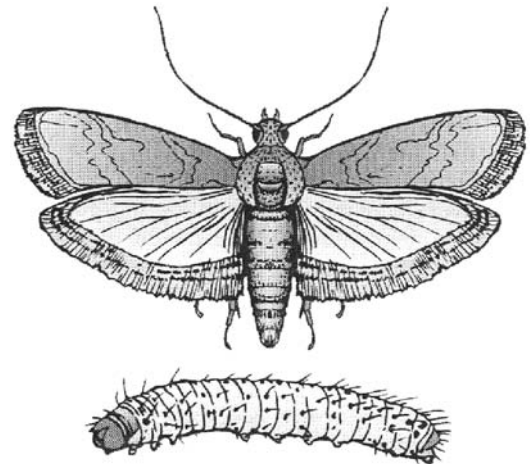

**Tobacco moth adult and larva**

Adult females lay up to 270 eggs singly or in small clusters on or near food. When they emerge, larvae move onto and over produce, feeding and spinning threads that can form webs. Larvae are pinkish to yellowish to offwhite with brown heads and pronotums. They molt five times and are about 1/2 inch long at maturity. When full grown, larvae migrate to sheltered areas to pupate.

Found worldwide, the tobacco moth is a severe pest of stored tobacco. It is a secondary

feeder that attacks the highest-priced tobacco grades since these contain the greatest amount of sugar. Larvae deposit silken webbing containing fecal pellets on the cured tobacco leaf as they feed. When infestations are high, tobacco moths may consume entire leaves except for the midvein. Tobacco moth larvae also feed on a range of cereal, vegetable and seed products. Adult tobacco moths do not cause damage.

### Webbing Clothes Moth

*Tineola bisselliella*

### Casemaking Clothes Moth

*Tinea pellionella*

The adult webbing and casemaking clothes moths look very similar. Adult clothes moths have four wings and a 1/2-inch-long wing spread. Their fore wings are light gray and sometimes mottled with brown scales. The hind wings are small and pale. Both sets of wings are fringed on the back margin. To distinguish between the species, look at their upper wings. The casemaking clothes moth has three dark

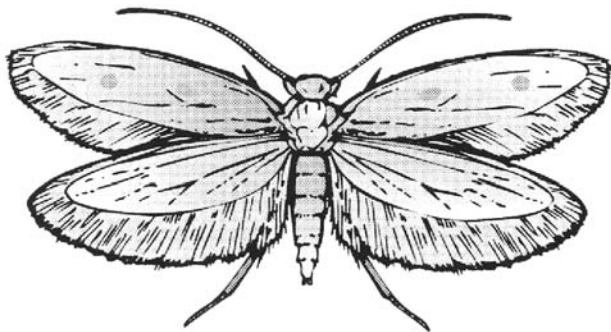

Casemaking clothes moth adult

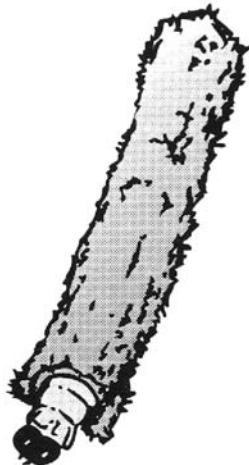

Casemaking clothes moth larva in a case

spots on its upper wings. These spots are absent on the webbing clothes moth.

Clothes moths mate and begin laying eggs two days after they emerge as adults. Females lay 40 to 50 eggs directly on food. Whitish larvae, less than 1/2 inch long, emerge in one to three weeks. The head and first segment of the larval body are brown. In exposed areas, larvae spin a silk tube or mat to cover their body. When they pupate, the larvae leave these empty cases and mats behind. The presence of silk tubes or mats is a sure sign of infestation.

Larvae feed on wool, feathers, bristle brushes, fur and other items made of animal fibers. They will also infest synthetic fabrics that are interwoven with animal fibers. Sometimes, clothes moths spin silken tunnels on infested woolens. Damage is most extensive to the surface of fabric. Adult clothes moths cause no damage.

### Control

To control moths attacking food and fabrics, prevention is key.

**Food Products** – Routine cleaning of all food handling equipment, with preventative spot fumigation, may reduce or eliminate the need for large-scale fumigation. Good sanitation involves removing spilled flour, meal, dust and other stored product in and around the holding area. Be sure to clean corners, floors and walls. Bits of product remaining can harbor insects that can move into the new products stored in the same area.

If an infestation does develop, first find and destroy infested materials. Then treat the location where they were stored. Thoroughly clean the area to remove spilled food products. Practice good housekeeping to prevent reinfestation.

**Fabrics** – Control small infestations by cleaning fabrics and storing them in tight containers with moth crystals. Large infestations such as in a warehouse may require fumigation. However, the problem must be severe enough and/or the products must be valuable enough to justify the expense of fumigation. Practice good housekeeping to prevent reinfestation.

Use fumigation as a last resort.

## Control of Moth Pests

To control moths, prevention is key. Routine cleaning of all storage facilities, with preventive spot treatments and space sprays, may reduce or eliminate the need for large-scale fumigation. Good sanitation involves removing spilled grain, grain dust and other stored products inside and outside the storage area. Be sure to clean corners, floors and walls. Bits of product remaining can harbor insects that can move into the new products stored in the same area. Also, make sure that grain and feed in adjacent buildings are not infested. Moths can fly from one building to the next.

Prevention also involves following good grain storage practices. Monitor for insect infestations and heating in stored grain. Aerate to maintain low moisture levels in the grain. Mix and level the grain so fines and other grain debris are evenly distributed throughout the grain. For more information on proper grain storage, see Unit 4

If an infestation does develop, find and destroy infested materials. Then treat the location where they were stored. Thoroughly clean the area to remove spilled product. Practice good housekeeping to prevent reinfestation. Use insecticides to help prevent damage when environmental conditions are favorable for moth infestations. Use fumigation as a last resort.

## Beetle Pests

There are hundreds of thousands of beetle species in the world. Fortunately, only a few attack raw agricultural and stored products. Those that do, however, can cause serious damage and large financial losses if left uncontrolled.

### Damage

Beetles attack a wide range of agricultural and stored products. Most species infest a specific commodity or type of commodity. For example, cigarette beetles prefer dried plant materials such as cured tobacco, herbs and spices. Rice, granary and maize beetles attack stored grains. By knowing which pest(s) attack(s) which product(s), you can more quickly pinpoint the source of damage.

## Life Cycle

Like moths, beetles develop by complete metamorphosis: egg, larvae, pupae and adult. Female beetles lay eggs singly or in small groups on a variety of foods. The larva, or “grub,” that hatches from the egg will feed on the available food. The grub stage may last 14 to 16 months. Full-grown grubs build cocoons out of scraps of food. They pupate inside these cocoons. After several weeks, adult beetles emerge. Adults live for several months or as long as one year. Both adult beetles and grubs are active feeders, damaging a range of stored products. In warm climates or heated buildings, beetles can produce six or more generations a year.

## Identification

Beetles are very diverse in appearance. However, there is one feature common to most beetle species. Adults have a pair of thin inner wings covered by a pair of shell-like outer wings. These outer wings are called “elytra” or “wing covers.”

The following are a few of the most common beetle pests of raw agricultural products.

### Cadelle

#### *Tenebroides mauritanicus*

Cadelle beetles are one of the largest stored-products pests. Adults measure 1/3 to 1/2 inch in length. They are long, flattened and shiny black. They have brown antennae and legs. Adult cadelles are long-lived, often surviving for more than a year.

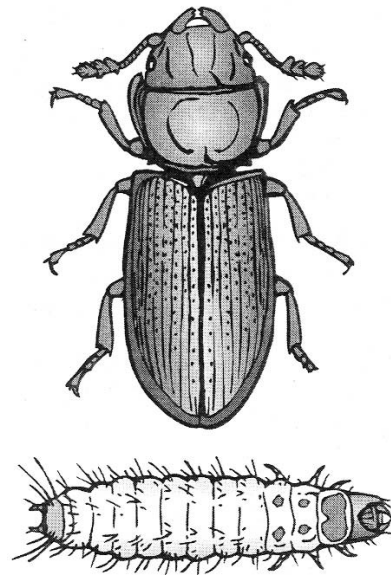

Cadelle adult and larva

The adult female cadelle lays about 1,000 eggs over several moths. Emerging larvae are grayish white with a black head and thoracic shield. When larvae are mature, they measure about 3/4 inch long. Larvae have a black plate with two hornlike projections on the upper side of their last abdominal segment.

Cadelle beetles are secondary pests. They attack grain in rice mills, flour mills and storage bins on farms. The larvae and adults feed by moving from grain to grain and devouring the germinal region. Cadelle larvae also cause damage by boring into the floor and walls of wooden storage bins. They sometimes burrow into empty bins as larvae and remain dormant until fresh grain is stored. A seemingly clean bin may hold thousands of insects. Cadelle larvae and adults are large and can go without food for 52 (adults) to 120 (larvae) days. Since they live for nearly one year, they are more common in old grain bins and flour mills.

**Cigarette Beetle**  
*Lasioderma serricorne*  
**Drugstore Beetle**  
*Stegobium paniceum*

Adult cigarette and drugstore beetles are small, oval insects. They usually measure 1/16 to 1/8 inch long. They look hump-backed because their heads are bent at an angle under their thorax. Their bodies are covered with small hairs that give them a silky, yellowish brown to reddish color. You can distinguish the two beetles by their antennae, wing covers and flight habits. Adult drugstore beetles have enlarged terminal segments of their antennae. They seldom fly and their wing covers have faint, longitudinal rows of punctures or pits. On the other hand, cigarette beetle antennae are sawlike. They often fly and they have scattered punctures over their wing covers.

Adults of both species are nonfeeding. The cigarette beetle female lays her eggs in groups of 30 to 40 eggs. Female drugstore beetles lay eggs singly. Both deposit their eggs on or near food sources. When the eggs hatch, tiny, C-shaped larvae emerge. The larvae are creamy white with yellow heads and brown mouth parts. Mature larvae are about 1/6 inch long. Larvae are often covered with the material they infest.

As its name implies, the cigarette beetle is primarily a pest of dried tobacco. It can infest stored, bundled leaves as well as finished

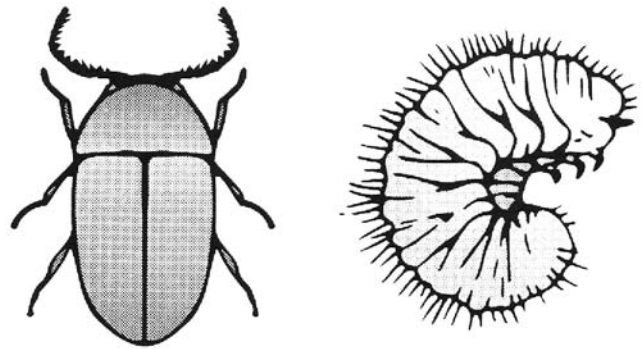

Cigarette beetle adult and larva

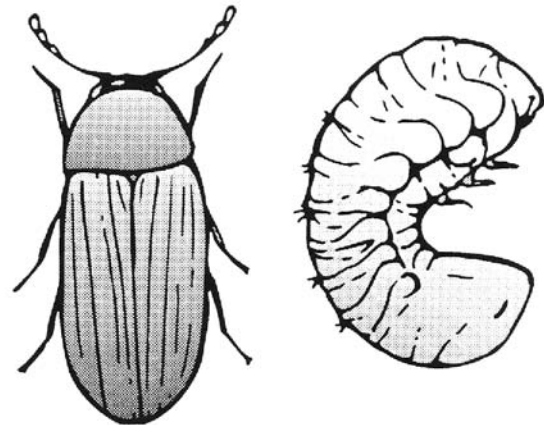

Drugstore beetle adult and larva

products like cigars and cigarettes. However, this beetle can also feed on a variety of stored food products including cereals, ginger, raisins, dates, pepper and dried fish.

The drugstore beetle feeds on a variety of foods and spices including red pepper, cayenne pepper, ginger and paprika. They also attack some medicines. Drugstore and cigarette beetles can penetrate most paper packaging materials.

**Confused Flour Beetle**  
*Tribolium confusum*  
**Red Flour Beetle**  
*Tribolium castaneum*

Adult confused flour beetles and red flour beetles are long, flat, shiny, reddish brown insects. They measure about 1/7 inch long. The head and upper parts of the thorax are densely covered with minute punctures or "pits." The wing covers are ridged lengthwise. You can distinguish between the two beetles by their antennae and ability to fly. The antennae of the confused flour beetle gradually enlarge toward the tip, producing a four-segment club. The red

flour beetle's antennae enlarge abruptly at the last few segments, giving the antennae a knobbed appearance. The red flour beetle is a strong flier. The adults are very active, especially in the evening hours. The confused flour beetle cannot fly.

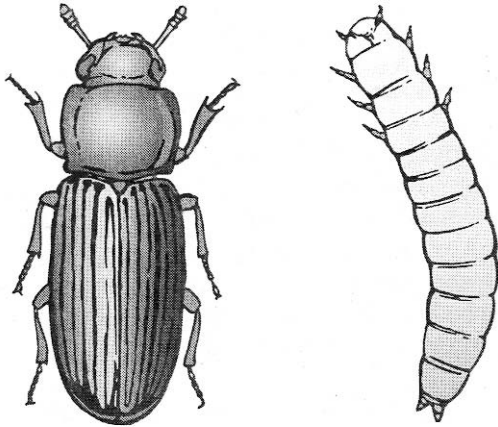

**Confused flour beetle adult and larva**

Female flour beetles lay an average of 450 eggs directly on the food source. Eggs are small and clear white. The female covers the eggs with a sticky secretion to which bits of the food adhere. Small, brownish white larvae hatch in five to twelve days. They are full grown in one to four months. A full-grown larva is about 3/16 inch long and tinged with yellow. Larvae feed on broken kernels, flour, meal and other starchy materials. They are often hard to detect because they cover themselves with bits of the food they infest. They may appear as tiny lumps in the flour. The larvae pupate and transform into adults.

Confused and red flour beetles are serious pests in flour mills. They do not penetrate whole grain kernels or undamaged grain. Instead, these secondary feeders cause damage by scraping the surface of foods or eating finely ground material. Their preferred foods include grains and grain products, peas, beans, flour, dried fruits, shelled nuts, spices and other commodities. These beetles may leave a bad odor that affects the taste of infested products.

### **Flat Grain Beetle** *Cryptolestes pusillus*

The adult flat grain beetle is tiny, flat and reddish brown. It measures 1/16 inch long. You can distinguish it from other stored-product pests by its long antennae, which often grow two-thirds the length of the insect's body.

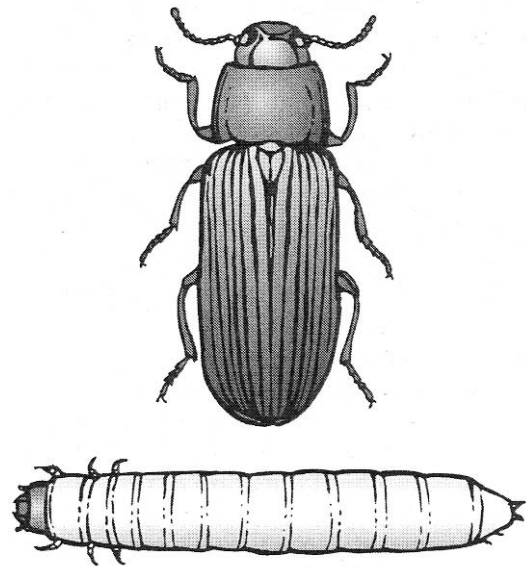

**Flat grain beetle adult and larva**

Female flat grain beetles lay small white eggs in the crevices of grain. When they emerge, larvae are slender and pale, with dark-colored legs and a dark head. Each larva has a pair of black, spinelike "tail horns" at the end of its body. Mature larvae form cocoons to which food particles stick.

The flat grain beetle is a widely distributed secondary pest. It primarily feeds on the germinal region of stored grains, especially wheat. It prefers damaged grain with a high moisture content.

### **Lesser Grain Borer** *Rhizopertha dominica*

The adult lesser grain borer is 1/8 inch long and shiny dark brown or black. It has a slender cylindrical form. Its body surface is somewhat roughened, and its head turns down under its thorax. Lines of small pits occur on the wing covers. Powerful jaws allow the lesser grain borer to bore into wood as well as grain. The last three segments of the antennae are enlarged on one side. Adult lesser grain borers are strong fliers and long-lived.

Adult female lesser grain borers lay up to 500 eggs singly or in clusters in loose grain. When the larvae emerge, they are C-shaped and white with dark heads and claws. Larvae burrow into and feed on the interior of nearly all types of stored grain. When mature, the larvae measure about 1/8 inch. They complete development by pupating inside grain kernels. It is often difficult to detect infestations of lesser

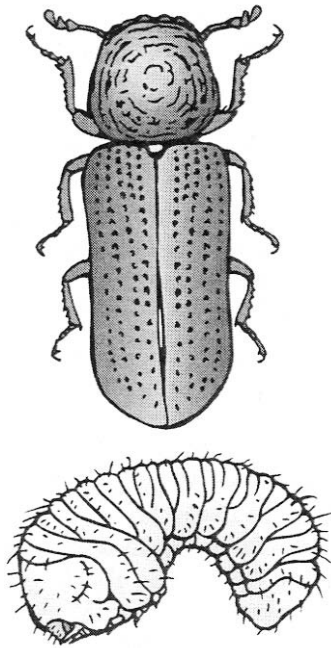

**Lesser grain borer adult and larva**

grain borers because the adults and larvae are usually together inside the infested grains.

Lesser grain borers occur worldwide. They are primary feeders that attack cereal and coarse grains, especially whole corn and wheat kernels. Both adults and larvae are voracious feeders and can penetrate packaging. Grain infested with the lesser grain borer has a characteristic sweet and slightly pungent odor. This odor contains a male-produced pheromone that has proven to be an effective lure for traps.

### **Rice Weevil**

*Sitophilus oryzae*

### **Granary Weevil**

*Sitophilus granaries*

### **Maize Weevil**

*Sitophilus zeamais*

Weevils are among the most destructive pests of grains, seeds and grain products. Most are primary feeders that attack the inside of grain kernels. Of these, the rice weevil, the granary weevil and the maize weevil are the most common in Arkansas.

Adult rice and granary weevils vary in size but average about 1/8 inch long. The bodies of rice and granary weevils are reddish brown to black with ridged wing covers. Their thoraxes are densely pitted. Their mouthparts form elongated snouts, characteristic of all weevils. You can distinguish between the granary and

rice weevils by the shape of their pits, the color of their bodies and their ability to fly. Adult rice weevils are dull in color and readily fly. They tend to have round pits covering the thorax. They also have four pale reddish to yellow marks on the corners of the wing covers. Adult granary weevils have oval pits, a polished coloration and they cannot fly.

Their wing covers are solid in color. The maize weevil and the rice weevil are so close in appearance that identification should be left to the experts. Maize weevils are slightly smaller than rice weevils.

Adult rice and maize weevils live for four to five months. Each female lays 300 to 400 eggs. Adult granary weevils can live for seven to eight weeks. Each female lays 50 to 200 eggs. Females of all three species use their strong mandibles to chew a small hole in a grain kernel. There they deposit a single egg and seal the hole with a gelatinous fluid. The small, white, legless larvae hatch, feed and develop inside kernels of grain. Since rice and maize weevils can fly, infestations may develop in the field before harvest. On the other hand, granary weevils cannot fly. You most often find these insects only where grain is stored.



**Rice weevil adult**

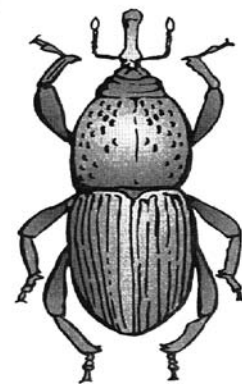

**Granary weevil adult**



**Rice/granary weevil larva**

Granary weevils are tolerant of low temperatures and cold climates. Within grains, larvae can survive at least ten weeks at 41°F. Adults easily overwinter in unheated buildings and bulk grain. Adult rice and maize weevils do not normally overwinter in cold climates unless the grain heats up due to a high moisture content.

Rice, granary and maize weevils are primary feeders that attack grain before harvest and in storage. They feed on both unbroken and broken grain kernels. Wheat, corn, oats, rice, sorghum and buckwheat are just some of their preferred foods. These pests also infest grain products such as spaghetti and macaroni. Both the adults and larvae damage agricultural products.

**Sawtoothed Grain Beetle**  
*Oryzaephilus surinamensis*

**Merchant Grain Beetle**  
*Oryzaephilus mercator*

Adults of these two beetles are 1/8 inch long, slender, dark brown and flat. They have sawtoothed-like projections on each side of the thorax. The larvae are yellowish white and less than 1/8 inch long. They become covered with the food they ingest and appear as small lumps in flour. Merchant grain beetles are known to fly, whereas sawtoothed grain beetles do not fly.

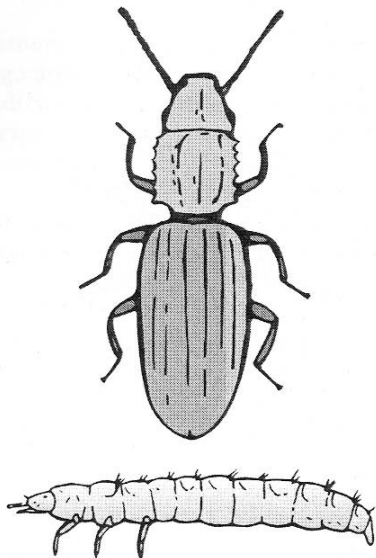

**Sawtoothed grain beetle adult and larva**

Adults of these two beetles usually live six to ten months, but some may live as long as three years. The female lays 50 to 300 eggs in flour, meal or other stored products. The eggs

hatch in flour, meal or other stored products. The eggs hatch in about four days, and the larvae begin feeding immediately. When the larvae are full grown, they construct cocoons out of fragments of foods. Within these cells, the larvae change to pupae and then to adults.

Sawtoothed and merchant grain beetles are secondary feeders that attack nearly all foods of plant origin. Although they are not able to attack intact kernels, they do cause a considerable amount of damage to grains by infesting slightly damaged pieces. Sawtoothed and merchant grain beetles also feed on grain products such as flour, meal, cereal and macaroni, as well as nutmeats, candy and dried fruits. Since these beetles are very flat, they easily hide in cracks and crevices and often penetrate improperly sealed packaged foods. The sawtoothed grain beetle prefers areas of high temperature and humidity.

**Yellow Mealworm or “Mealworm Beetle”**  
*Tenebrio molitor*

Adult mealworm beetles are about 1/2 inch long. Their bodies are shiny dark brown or black. Tiny punctures occur in rows along the wing covers. The antennae are slightly clubbed at the tip. Yellow mealworm beetles have well-developed wings and are strong fliers.

Adult mealworm beetles lay their eggs in grain or food products. Each female produces up to 500 bean-shaped eggs. The eggs are white and sticky, quickly becoming covered with food particles. Larvae are pale brown to yellow,

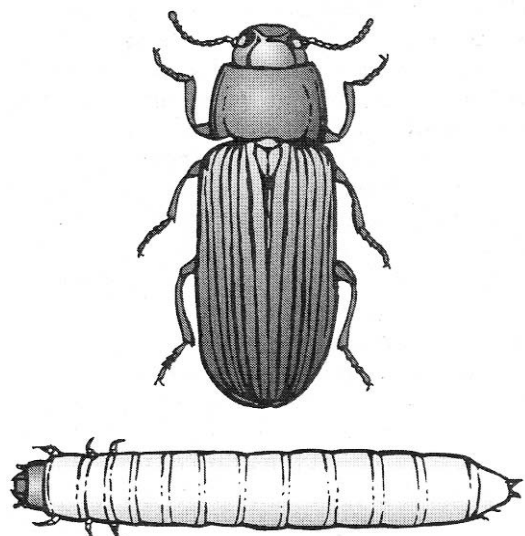

**Yellow mealworm beetle and larva**



smooth and hard bodied. When fully developed, they measure 1 1/4 inches long. Larvae develop slowly, living at least one year. They pupate near the surface of the food.

The mealworm beetle is a common pest of grain, grain dust and debris. Yellow mealworm infestations typically indicate poor sanitation. You may find them in grain spillage, neglected corners where grain dust has accumulated or under bags of grain. They also occur in poultry houses, where chicken droppings mix with grain.

## Larder Beetle

### *Dermestes lardarius*

Adult larder beetles are 1/4 to 3/8 inch long, oval and elongated. They are dark brown to black with a broad pale yellow band across the front third of their wing covers. The band is speckled with darker spots. Also noticeable are the short, clubbed antennae.

Adult females lay 100 to 800 eggs on food or in cracks where food is stored. Brown, hairy larvae emerge in 12 days. They range in length from 3/8 to 5/8 inch. To pupate, larder beetle larvae bore into solid materials such as ham and wood. After three to five days, adults emerge.

Adults and larvae feed on a variety of animal products including dried fish, ham, bacon, meats, cheese and dried pet food. They will also attack dried museum specimens such as insects, hides, feathers, horns and hair. Larvae cause most of the damage, but adult feeding can also cause problems. Larder beetles are often found with masses of dead insects gathered at windows or ventilators.

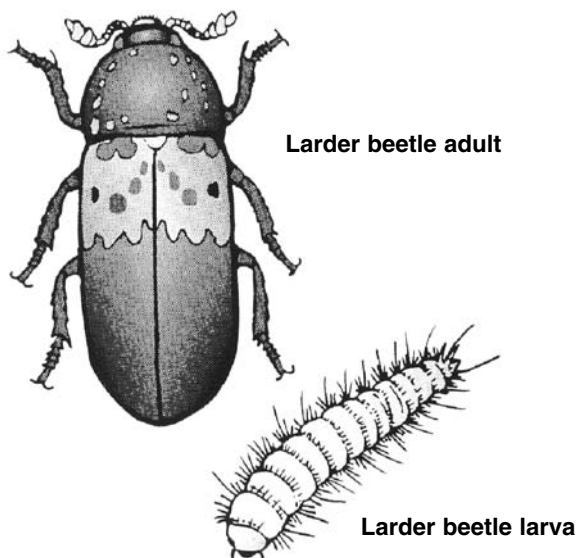

Larder beetle adult

Larder beetle larva

## Control

Controlling beetles in stored products is much the same as controlling moths. Prevention is key.

**Food Products** – Clean in and around storage areas regularly. Good sanitation involves removing spilled flour, meal, dust or other stored product in and around the holding area. Be sure to clean corners, floors and walls. Bits of product remaining can harbor insects that can move into new products stored in the same area. Apply nonfumigant pesticides to areas that are hard to reach. Routine cleaning, with preventative spot fumigation, may reduce or eliminate the need for large-scale fumigation.

If an infestation does develop, first find and destroy infested materials. Then treat the location where they were stored. If the infestation is severe, you may need to fumigate. Practice good housekeeping to prevent reinfestation.

**Animal Products** – Practice good sanitation to prevent larder beetle infestations. This involves keeping areas free of hair, dead insects, spilled animal food and other items in which larder beetles commonly nest. When small infestations develop, find and remove infested items. If you cannot identify the source of infestation and the problem is severe, fumigation may be necessary. Fumigation may also be needed when an individual item, such as an animal hide, is attacked. This is true if

- other control options such as chemical sprays would damage the item, or
- other types of pesticides are not able to penetrate the item and kill the beetles.

## Control of Beetle Pests

Controlling beetles in stored products is much the same as controlling moths. Prevention is key. Start by cleaning in and around product storage areas regularly. Practice good sanitation by removing spilled grain, grain dust and other stored product inside and outside the storage area. Be sure to clean corners, floors and walls. Bits of product remaining can harbor insects that can move into new products stored in the same area. Apply nonfumigant pesticides to areas that are hard to reach. Routine cleaning, with preventive spot fumigation, may reduce or eliminate the need for large-scale fumigation.

Prevention also involves following good storage practices. Monitor for insect infestations and heating in stored products and grain. Aerate the storage facility to maintain low moisture levels in the grain. Mix and level the grain so fines and other grain debris are evenly distributed throughout the grain. For more information on proper grain storage, see Unit 4.

If an infestation does develop, first find and destroy all infested products. Then treat the location where they were stored. If the infestation is severe, you may need to fumigate. Practice good housekeeping to prevent reinfestation.

## Other Pests

### Identification

#### Grain Mites

##### *Acarus siro*

Mites are not insects. They belong to a group of arthropods called “arachnids.” This same group includes spiders. Mites look and behave much like insects with a few differences. Adult mites have eight legs and two body segments. Insects have six legs and three body segments.

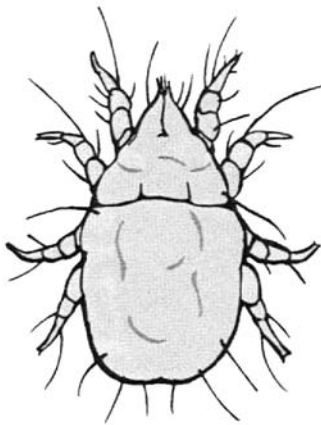

Grain mite

Mites go through three stages of development: egg, nymph and adult. Some references refer to the first nymphal instar as a larva, but it is technically a nymph. Adult and nymphal mites have eight legs and are similar in appearance.

Adult grain mites are pearly white with pale yellow to reddish legs. Their bodies are oval, measuring about 1/128 to 1/64 inch long. Two pairs of long hairs trail from the rear of the body. Grain mites are not hard shelled.

Mites develop by gradual metamorphosis. An adult female can lay up to 800 eggs in her lifetime. She deposits white, oval eggs one at a time directly in food material. When the larvae hatch, they feed and grow quickly for about three days. Fungi attract the mites to the food source. Fungi on unbroken grain weaken the hull, allowing mites access to the germ where they feed and reproduce. Mites cannot survive when the humidity drops below 60 percent. Their life cycle takes 17 to 28 days.

Also called the “flour mite,” the grain mite occurs worldwide. It infests grain and flour with a high moisture content. It is responsible for “mite dust” on the surface of cheese or on the floor near bags of flour or wheat. Grain mites also attack cereals, animal feeds, dried fruits and other vegetable materials. The grain mite occurs in fields, barns, bird nests, grain elevators and other areas. By attaching itself to insects, birds and other animals, the grain mite can disperse widely. Large populations leave a characteristic minty odor. Grain mites can cause a type of dermatitis in humans known as “grocer’s itch.”

### Control of Grain Mites

The best way to control grain mites is to monitor the humidity and moisture level in and around stored products. Ventilate storage areas well. Keep the relative humidity below 60 percent. It is also important to move susceptible products and clean storage areas periodically.

When small infestations develop, remove and destroy the infested product. Clean the area thoroughly. Apply a nonfumigant pesticide to kill remaining mites and their eggs. Large infestations usually require fumigation.

Accurate identification of pests is vital for control methods of any type to be effective. Once you decide fumigation is the best way to control the pest, your knowledge of methods and application procedures comes into play.

## Test Your Knowledge

**Q. Give several examples of raw agricultural products.**

- A. Whole grains (corn, wheat, rye, etc.) cured tobacco, baled cotton and seeds.

**Q. Describe the difference between primary and secondary feeding insects.**

- A. Primary feeding insects are capable of destroying whole, sound grain. The most damaging primary feeders are those that develop within grain kernels. These insects feed on the “germinal” region (early growth) of the seed, reducing its nutritional value and its ability to sprout. Adult females of internal feeders deposit eggs on or in whole kernels. Larvae develop within the kernels.

Secondary feeding insects feed only on damaged grains and seeds. The outer layer of the grain or seed must be damaged – cracked, holed, abraded or broken. Secondary feeders live in grain storage areas or in flours, meals and other processed cereal products.

**Q. Is damp grain or dry grain more susceptible to insect infestation?**

- A. Damp grain.

**Q. What stage in a moth’s life cycle causes damage to stored products?**

- A. The larval (caterpillar) stage.

**Q. How can you distinguish between moth larvae and beetle larvae?**

- A. Look at the middle of their bodies. Moth larvae usually have fleshy, leglike appendages called prolegs on several of the middle segments of their bodies. Prolegs are absent on the middle segments of beetle larvae.

**Q. Describe the life cycle of a moth.**

- A. Moths develop by complete metamorphosis. Females lay eggs singly or in small groups. The caterpillars that hatch from the eggs feed on nearby food. Each caterpillar grows and sheds its skin several times. After

feeding for several weeks, the caterpillar spins a cocoon. In the cocoon, it transforms into a pupa. The adult moth emerges in about 30 days. Adults live for a short time and do not feed. Females die soon after they lay their eggs.

**Q. A pest has spread silk webbing over some stored grain. Which of the following insects is most likely the cause?**

- Indianmeal moth
- Rice weevil
- Grain mite
- Sawtoothed grain beetle

- A. The Indianmeal moth

**Q. If the kernels in the top few inches of grain in a bin each have a small hole in one end, what pest is most likely the cause?**

- A. The Angoumois grain moth.

**Q. What is the best way to prevent moths from attacking stored grain and other raw agricultural products?**

- A. Good sanitation. This involves removing spilled grain, grain dust and other stored product inside and outside the storage area. Be sure to clean corners, floors and walls. Bits of product remaining can harbor insects that can move into the new products stored in the same area. Also, make sure that grain and feed in adjacent buildings are not infested. Moths can fly from one building to the next. Prevention also involves following good grain storage practices. Monitor for insect infestations and heating in stored grain. Aerate to maintain low moisture levels in the grain. Mix and level the grain so fines and other grain debris are evenly distributed throughout the grain.

**Q. On what grade of tobacco does the tobacco moth normally feed? Why?**

- A. The tobacco moth attacks the highest-priced tobacco grades since these contain the greatest amount of sugar.

**Q. On what products does the Mediterranean flour moth normally feed?**

A. The Mediterranean flour moth is a secondary feeder that prefers flour and meal. However, it also infests grain, nuts, seeds and other stored foods.

**Q. True or False: Like moths, beetles develop by complete metamorphosis.**

A. True.

**Q. What stages in a beetle's life cycle damage stored products?**

A. Adult beetles and beetle larvae (grubs) damage stored products. Both stages have chewing mouthparts, enabling them to feed on a variety of products.

**Q. The larvae of what beetle bore into the floors and walls of wooden storage bins?**

A. The cadelle.

**Q. How can you distinguish between adult rice weevils and adult granary weevils?**

A. You can distinguish the two beetles by the shape of their pits, the color of their bodies and their ability to fly. Adult rice weevils are dull in color and readily fly. They tend to have round pits covering their thoraxes. Adult granary weevils have oval pits, a polished coloration and they cannot fly.

**Q. Which species of beetles prefer to feed on the germinal region of grains?**

A. The cadelle, the flat grain beetle and the lesser grain borer.

**Q. Why are lesser grain borer infestations often hard to detect?**

A. The adults and larvae are usually together inside the infested grains.

**Q. What is the preferred food of the cigarette beetle?**

A. The cigarette beetle feeds on dried tobacco products, including whole leaves, cigars and

cigarettes. It also feeds on stored food products, including cereals and spices.

**Q. Why are flour beetle larvae hard to detect?**

A. They are small, and they cover themselves with bits of the food they infest. They may appear as tiny lumps in flour. However, unless a stored product is sifted, the larvae are usually hard to find.

**Q. Which of the following pests penetrate intact grain kernels?**

- Rice and granary weevils
- Confused and red flour beetles
- Sawtoothed and merchant beetles

A. The rice and granary weevils.

**Q. What do sawtoothed grain beetles and merchant grain beetles feed on?**

A. Nearly all foods of plant origin. Although they are not able to attack intact kernels, they do cause a considerable amount of damage to grains by infesting slightly damaged pieces. Sawtoothed and merchant grain beetles also feed on grain products such as flour, meal, cereal and macaroni, as well as nutmeats, candy and dried fruits.

**Q. Describe the preferred habitat of mealworm beetles.**

A. Mealworm beetles prefer dark, damp areas to feed on grain, grain dust and debris. Yellow mealworm infestations typically indicate poor sanitation. You may find them in grain spillage, neglected corners where grain dust has accumulated or under bags of grain. They also occur in poultry houses, where chicken droppings mix with grain.

**Q. What is the best way to prevent mites from damaging stored products?**

A. Control grain mites by monitoring the humidity and moisture level in and around stored products. Ventilate storage areas well. Keep the relative humidity below 60 percent. It is also important to move susceptible products and clean storage areas periodically.

# Pests of Wood

Each year, Arkansas home and business owners lose thousands of dollars due to damage caused by termites, beetles and other wood-destroying insects. These insects not only harm the appearance of wood; they can also reduce its strength and integrity. Many wood-destroying insects can be controlled with surface or contact pesticides. Others spend their entire lives within the wood. These insects may never come to the surface or roam within the structure itself. Consequently, they may not be vulnerable to surface treatments. In these cases, fumigation may be the only logical approach.

Wood-destroying insects attack both structural wood and unfinished wooden products. The most common wood-destroying insects controlled by fumigation include drywood termites, powderpost beetles and old house borers.

*NOTE: Under some conditions, fumigation may control a severe carpenter ant infestation or a subterranean termite colony that is surviving without soil contact. Some termites form “aerial” nests and can live solely within their galleries. Carpenter ants have been found infesting flat roofs with foam insulation. In such cases, fumigation of a structure for these wood-destroying pests may be appropriate.*

## Termites

Termites are one of the most serious and destructive pests of wood structures and wood products in the United States.

### Damage

Termites live within soil or wood. They require wood or wood products for food. Colonies often live in stumps and decaying logs, but are capable of invading buildings and feeding on structural wood as well. In nature, termites are beneficial because they break down dead and dying plant material. In wooden structures, however, termites become pests.

### Life Cycle

Termites live in colonies. Each colony contains specialized groups of termites called “castes.” Each caste performs certain jobs or

functions that are necessary for the survival of the colony. In general, there are four castes of termites. These include:

- **Workers** – Creamy white and wingless insects. Workers gather food, maintain the galleries, tend the young and groom the other termites.
- **Soldiers** – Wingless insects with enlarged heads and swordlike mandibles (jaws). Soldiers guard the colony against predators.
- **Primary Reproductives** – Dark colored insects with wings and large eyes. Primary reproductives are the future kings and queens of new termite colonies. In the spring, these “swarmers” fly out of their colonies to start new colonies of their own. This caste is produced in mature colonies (three to five years and older).
- **Secondary Reproductives** – With only wing pads, these reproductives will never leave the colony. They supplement egg production in the presence of the king and queen. They can also take over the egg laying if the queen dies or begins to fail. Like primary reproductives, this caste is only present in mature and growing colonies. Each colony also has a king and a queen. These individuals reproduce constantly. A mature queen may lay 5,000 to 10,000 eggs per year. In three to five years, a new colony can reach a mature size of 60,000 termites or more. The king and queen of termite colonies start out as primary reproductives.

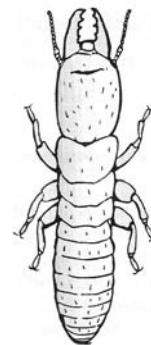

Drywood termite soldier

### Identification

Termites are small yellowish white to brown insects. Their identification can be tricky. Many people confuse winged termites with flying ants.

Both swarm near structures. You can tell them apart by comparing three things:

Character	Winged Termites	Winged Ants
Antennae	straight	bent
Waists	thick	narrow
Wings	equal size and shape	fore wings larger than hind wings

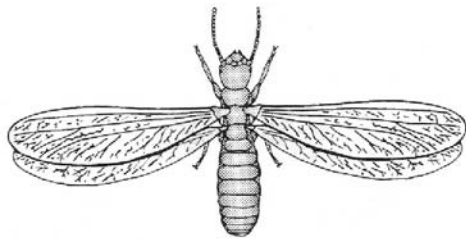

Winged termite

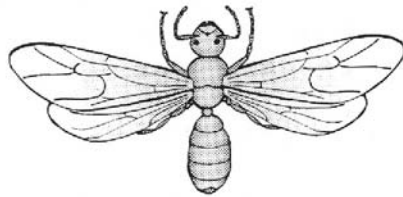

Winged ant

Three types of pest termites occur in the United States: dampwood, subterranean and drywood termites.

### Dampwood Termites (scientific name varies)

Dampwood termites are not found in Arkansas. Their distribution is limited to coastal areas of southern states where they infest wood saturated with water. Controlling excess moisture can eliminate these pests.

### Eastern Subterranean Termites (*Reticulitermes flavipes*)

Eastern subterranean termites occur throughout Arkansas. It is the species of termites that most commonly infests structures. They have strict moisture needs and therefore nest in the soil and forage underground. Subterranean termites feed on wooden structures such as buildings, telephone poles and fence posts. Occasionally, they attack living trees and shrubs.

Control of subterranean termites is limited to liquid treatments and baiting systems. Fumigants are usually not effective because subterranean termites almost always nest underground. Applying a fumigant to a structure infested with subterranean termites will control only the insects inside the structure. The underground nest will remain unharmed. In time, reinfestation may occur. Using fumigants to control subterranean termites is usually a waste of time and money, and it places chemicals into the environment unnecessarily.

### Southeastern Drywood Termites (*Incisitermes snyderi*)

As a rule, the southeastern drywood termite is the only type of termite successfully controlled by fumigation in Arkansas. However, drywood termites are not common in Arkansas. When they do occur, you can usually trace their origin to furniture or other wood moved into Arkansas from tropical countries or southern regions of the United States.

Drywood termites attack wood directly. They require little moisture, so they live entirely within the wood and have no connection with the soil. As they feed, they cut across the grain of wood, excavating large galleries connected by small tunnels.



Drywood termite frass pellets

They produce small, cylindrical fecal (frass) pellets with six depressions on the sides. The termites often push the pellets out of the infested wood through small holes. These frass pellets are unique to drywood termites and are used for identification.

Drywood termites most often infest exposed wood such as window and door frames, trim, eaves and attics. They also damage furniture, picture frames and other individual items.

### Control

Control drywood termites by eliminating the colony. You can accomplish this by treating the infested furniture or wood through vault fumigation or by drilling and injecting chemicals into the galleries. Fumigation of a whole structure is usually the only practical and effective method in areas of high infestation. Soil treatments are not effective.

## Beetles

Several types of beetles invade and damage wood. These include powderpost beetles and the old house borer.

### Powderpost Beetles

#### *Lyctidae, Anobiidae, Bostrichidae*

There are three families of powderpost beetles: *Lyctidae*, *Anobiidae* and *Bostrichidae*. They most often attack joists, subflooring, hardwood flooring, sill plates and interior trim. Powderpost beetles may also damage furniture and other wood products. If only a single generation of larvae has fed within the wood, it is usually still structurally sound. However, the feeding of generation after generation can reduce the strength and integrity of the wood.

Adult powderpost beetles are small and reddish brown to nearly black. The larvae are curved and lightly colored. Powderpost beetle larvae feed on seasoned wood. In the tunnels, they leave undigested wood particles called “frass.” Frass usually appears as a fine wood dust or powder. When you cut or break infested wood, the interior reveals galleries filled with frass. Slight jarring of the wood often causes a fine powder to sift from the holes. These are all sure signs of a powderpost beetle infestation.

Powderpost beetle larvae pupate in the wood. When the adults emerge, they work their way out of the wood leaving “exit holes.” Exit holes range in size from 1/32 to 5/16 inch wide, depending on the species of beetle that made them. All powderpost beetle exit holes are round. Pest control operators often use exit holes to identify which beetle is causing the problems.

### Lyctid Beetles

Lyctid beetles are known as “true powderpost beetles.” Adults are small, slender, flattened and reddish brown to black. They vary in length from about 1/32 to 1/4 inch long. Lyctids usually infest the sapwood of hardwood lumber and manufactured products. Females lay up to 50 eggs in the pores of the wood. Once hatched, larvae bore into the wood. Larvae are C-shaped, 1/4 inch long and nearly white. The frass of lyctids

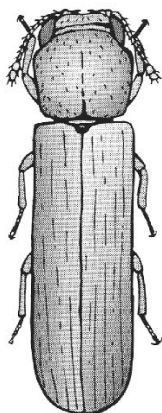

Lyctid beetle

tends to be finer and more powdery than that of other powderpost beetles. It is also more abundant. Exit holes are tiny, ranging from 1/32 to 1/8 inch wide.

### Anobiid Beetles

Anobiid beetles include the furniture and deathwatch beetle. Both species have similar features. Adult anobiids are slightly less than 1/8 to 1/4 inch long and red to brown to black in color. Females deposit their eggs in cracks and crevices of seasoned wood. Anobiid beetles seem to prefer the sapwood of softwood lumber and manufactured products. When the larvae emerge, they begin to feed and produce frass that is coarse and powdery. Larvae are C-shaped, 1/2 inch long and nearly white. The frass also contains distinctive fecal pellets shaped like hotdog buns. Exit holes range from 1/16 to 1/6 inch wide.

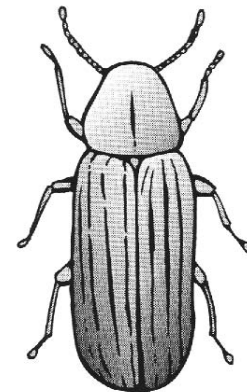

Anobiid beetle

The furniture beetle infests structural wood and furniture. The deathwatch beetle prefers structural timbers in damp areas. The deathwatch beetle gets its name from the ticking sound it makes in the dead of night.

### Bostrichid Beetles

Bostrichid beetles, also known as “false powderpost beetles,” are harder than lyctids or anobiids. Adult bostrichids are cylindrical. Their heads are rarely visible from above, giving them a humped-back appearance. Color varies from dark brown to black and length from 1/16 to 1 inch. The C-shaped larvae are less than 1/2 inch long and nearly white. They produce a grainy or mealy frass that is tightly packed in the galleries. Bostrichids attack both softwood and hardwood lumber. Exit holes are large, ranging from 1/16 to 5/16 inch wide.

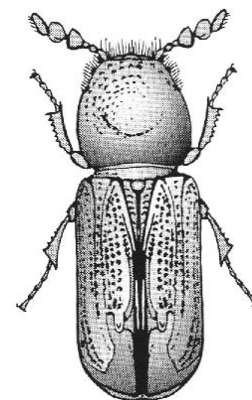

Bostrichid beetle

## Beetle Control

Powderpost beetle problems occur in hardwood flooring, old buildings, log homes, antiques and other valued wooden items. Floors of recently constructed buildings sometimes show infestations appearing as exit holes. These holes are usually restricted to a few boards in an entire room. The usual cause is the inadvertent use of one or two pieces of infested lumber when the floor was laid. Fortunately, only a single generation of powderpost beetles will emerge. The presence of floor fillers, varnishes and waxes will prevent further egg deposits. Treatment is not usually necessary. However, the beetles can attack old hardwood items on which the finish has become weak.

Pest control operators must sometimes treat suspected infestations of powderpost beetles that occur in the structural members (sills, joists, girders, etc.) of old houses. To determine whether there actually is an active infestation, examine 100 holes at random. Look for holes that contain fresh sawdust and are not discolored from long exposure to the air. These holes are “new.” If there is an active but small, localized infestation, coat the wood with a nontoxic, permanent surfacing material instead of fumigating.

When beetles are emerging from cabinets, flooring, moldings, furniture or other valuable items, you may need to fumigate to stop the damage that the exit holes can create. No chemical treatment other than vault fumigation is likely to penetrate in lethal enough quantities to prevent emergence.

*NOTE: Female powderpost beetles will not deposit their eggs into wood that is treated with a coating such as paint, varnish, whitewash or waterproofing material. Thus the wood, if protected on all surfaces, will not be attacked.*

### Old House Borers (*Hylotrupes bajulus*)

The name “old house borer” can be misleading. This insect is as likely to attack timbers in recently constructed houses as it is old ones. In fact, the old house borer is mainly a pest of newer structures. It requires seasoned, wide-grain wood of softwoods such as pine, spruce and fir. These woods must have at least one surface that is free of paint or other permanent finish.

Old house borers belong to the Cerambycidae or “longhorn” beetle family. Adults are about 3/4 inch long and grayish brown to black. They have two white patches on the wing covers. Larvae are 1 1/4 inch long and nearly white. Old house borers feed only on softwoods such as pine. The larvae leave distinctive ripples on the surface of the galleries. Unlike powderpost beetles, old house borers leave irregularly-shaped (often oval) exit holes from 1/4 to 3/8 inch wide. Gallery ripples and large, oval exit holes are used to identify old house borer damage.

An old house borer infestation often spans several decades. The life cycle of one beetle ranges from three to twelve years. Damage is most likely to occur in attics and other areas not frequently examined. An infestation may also develop if infested wood is used to build a new structure. In this case, the emergence holes of the adult beetles may appear at the surface of plaster, drywall and other hard and unlikely substances. Old house borers commonly reinfest.

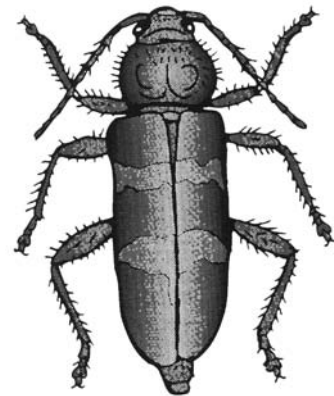

Old house borer

### Old House Borer Control

Like powderpost beetle infestations, you can prevent old house borer damage by covering all surfaces of wood with a paint, varnish or similar treatment. This prevents female beetles from laying eggs on the surface of the wood.

Where there is an ongoing infestation of old house borers, control is usually a long-term project. In widespread infestations, spot treatments with residual sprays may not work. Fumigation may be necessary.



## Test Your Knowledge

**Q. Why is structural fumigation not usually effective against subterranean termites or carpenter ants?**

- A. Subterranean termites almost always build their nests or galleries underground. Carpenter ants usually build their primary nests outside of structures. While a fumigant will kill the insects within the structure, underground and outdoor nests will remain unharmed. In time, reinfestation may occur.

**Q. Name the three most common wood destroying insects controlled by fumigation.**

- A. Drywood termites, powderpost beetles and old house borers.

**Q. How can you distinguish between winged termites and winged ants?**

- A. Look at their antennae, waists and wings. Winged termites have straight antennae, thick waists and wings that are equal in size and shape. Winged ants have bent antennae, narrow waists and fore wings that are larger than the hind wings.

**Q. Describe the frass pellets of drywood termites.**

- A. They are small and cylindrical with six depressions on the sides. These pellets are unique to drywood termites and are used for identification.

**Q. Name the four castes of drywood termites. Which caste is the most commonly seen?**

- A. Workers, soldiers, primary reproductives and secondary reproductives. Soldiers are the caste most commonly seen.

**Q. Describe the frass of powderpost beetles?**

- A. Powderpost beetle frass appears as a fine wood dust or powder. Slight jarring of infested wood can cause the frass to sift from holes. This is a sure sign of a powderpost beetle infestation. In addition, the frass of anobiid beetles has a distinctive hotdog bun shape.

**Q. What are exit holes? Why are they important to pest control operators?**

- A. An exit hole is the location where an adult beetle has emerged from wood. Exit holes range in size and shape depending on the species of beetle that made them. Because adult beetles are rarely seen, exit holes are often the best and only way to identify the infesting beetle.

**Q. Name three types of powderpost beetles.**

- A. Lyctid, anobiid and bostrichid.

**Q. How can you protect wood from being attacked by wood-boring beetles?**

- A. Treat wood on all sides with a coating of paint, varnish, whitewash or other sealant. Female beetles will not deposit their eggs on treated wood surfaces.

**Q. Describe the difference between the exit holes of powderpost beetles and the exit holes of old house borers.**

- A. Powderpost beetle exit holes are generally small (1/32 to 1/4 inch wide) and perfectly round. Old house borer exit holes are larger (1/4 to 3/8 inch wide) and irregularly shaped.

**Q. True or False: Old house borers attack only aged wood.**

- A. False.

## Miscellaneous Pests

A few pests controlled by fumigation do not normally damage stored products or wood. The most common of these are the bed bug (*Cimex lectularius*) and rodents.

### Bed Bugs (*Cimex lectularius*)

Bed bugs are a type of “true bug.” Adults are 1/4 inch long, reddish brown, wingless, oval and flat. Females lay whitish eggs in cracks and crevices. When nymphs emerge, they are smaller and lighter in color than the adults. There are five nymphal stages. Each one requires a blood meal to molt to the next stage.

Adults and nymphs feed on human skin at night, and hide in cracks and crevices of sleeping areas during the day. Heavily infested areas have a characteristic “musty” odor. Bites cause intense irritation and swelling. They appear as small, whitish, hardened spots surrounded by larger inflamed areas. Nymphs and adults can withstand long periods of starvation.

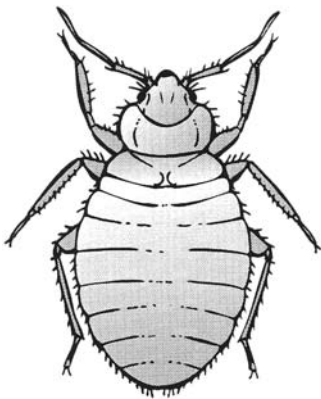

Bed bug adult

Bed bug infestations most often develop in settings where large numbers of people live. Examples include apartment buildings, nursing homes and prisons.

### Control

Prevent bed bug infestations with good sanitation. If infestations still occur, pesticides may be necessary.

Fumigation is rarely practical to control bed bug populations. This is largely because of where bed bugs cause problems. Evacuating large numbers of people from nursing homes or

apartment buildings can be difficult or even impossible. Prisons create the biggest challenge. Instead, control bed bug infestations with contact pesticides when possible. Routine applications may be necessary. Take special care when treating mattresses, box springs and upholstery. Keep pesticide exposure to your client low. Do NOT treat infants' or sick persons' bedding or bed frames. Instead, replace them with uninfested items.

Occasionally, you may need to treat an area occupied by residents who are sensitive to pesticide sprays. Examples include nursing homes and day care centers. In these cases, fumigation may be a better alternative. Remember, fumigation is usually reserved for severe situations only.

## Cockroaches

There are more than 4,000 species of cockroaches in the world. However, only about ten are normally found living with people. These ten species have adapted to human habits. Our homes and other structures (for example, warehouses) provide them shelter, food and water. In Arkansas, the most common invaders are the American cockroach, German cockroach, Oriental cockroach and brownbanded cockroach.

### Damage

Cockroach infestations are not only a nuisance; they threaten human health and product quality as well. Cockroaches contaminate food with their feces, their body parts and the disease-causing organisms they carry. Cockroaches carry four strains of poliomyelitis, more than 40 different disease-causing bacteria and the eggs of several pathogenic worms. In addition, they have an unpleasant odor. Cockroaches contaminate nearly all stored products including food, packing materials, glues and pastes, grease, soaps, fabrics and other items. They also transfer stains and odors to surfaces they touch.

### Life Cycle

Cockroaches undergo gradual metamorphosis. Females do not lay eggs one at a time. Instead, they produce small egg cases that contain from 6 to 40 eggs. The number of eggs per case varies by species. Females deposit their egg cases in protected places with adequate food and water.

“Nymphs” begin feeding soon after they hatch from the egg case. They have the same diet as the adults. Nymphs look like small wingless adults. After shedding their exoskeletons several times to grow larger, they become mature, reproductive adults.

Most mature cockroaches have wings. Adults live for a few months to over a year, depending on the species. They mate several times, and the females generally produce one egg case per month.

## Identification

Cockroaches vary somewhat in their appearance and habits. All species have chewing mouth parts and flattened oval bodies. Their antennae are long and slender. When viewed from above, the head is covered by a shieldlike structure called a “pronotum.” Some species have well-developed wings. Others have no wings. Cockroaches are fast-moving insects that seek cover in the daytime or when disturbed at night. However, when infestations are heavy, you can see cockroaches foraging during the day.

The following describes the features, behavior and preferred food of the four most common cockroach pests in Arkansas.

### American Cockroach (*Periplaneta Americana*)

The American cockroach is the biggest species in Arkansas. Adults range from 1 1/3 to 1 1/2 inches in length, but may grow as long as 2 inches. Adults are reddish brown. The pronotum has a light-colored margin. In this species, the male has wings longer than the abdomen. The female’s wings are shorter, just covering the abdomen.

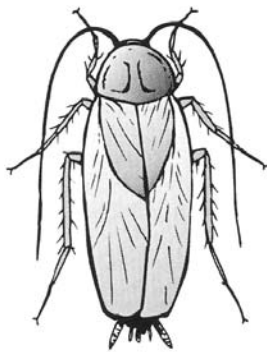

**American cockroach**

The female American cockroach usually deposits her egg case as soon as she produces it. She may live for 12 to 18 months and usually lays 10 to 15 egg cases.

Nymphs feed on the same material as the adults. They take a year or more to complete their development. Adults and nymphs actively

forage during the warm months of the year. American cockroaches are inactive during the winter, even in warm climates.

American cockroaches prefer warm, moist and dark habitats. They often infest basement areas near water heaters, floor drains or water sumps. They also like boiler rooms, sewer systems and warehouses. In Arkansas, this species is primarily an indoor pest. However, some individuals will move outdoors during the warm months. This can occasionally cause indoor control efforts such as fumigation to be ineffective if pests are able to escape to the outdoors. American cockroaches move by running from place to place. They have wings, but rarely fly.

American cockroaches damage all types of stored products including food, packing materials, glue, fabric and other items. Like Oriental cockroaches, American cockroaches produce frass that can stain and damage many items.

### German Cockroach (*Blattella germanica*)

The German cockroach is the most common and wide-spread structural cockroach. Adults are 1/2 to 3/4 of an inch long. Their bodies are yellowish-brown with two dark stripes running lengthwise on the pronotum. Both males and females have well-developed wings, but they do not fly. Wings cover the entire abdomen.

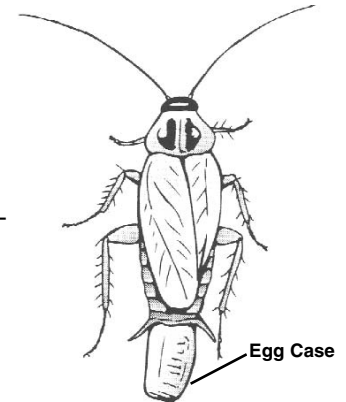

**Female German cockroach with egg case**

German cockroaches lay small brown egg cases. Each egg case contains from 30 to 40 eggs. The female carries the egg case until about 24 hours before the eggs are ready to hatch. Then, she places the egg case near food, water and shelter. Once she becomes an adult, a female lives about six months. On average, she will produce one egg case a month, yielding about 240 nymphs. The average life cycle is about 100 days under favorable conditions.

While females are producing and carrying an egg case, they are inactive. They do not feed or

seek water and often remain hidden. This can protect them and their young from certain pest control efforts such as baits and sprays. However, it does not protect them from fumigation.

German cockroaches live indoors only. They will eat almost any food consumed by humans. They are most commonly found where food is handled or stored. German cockroaches also damage other stored products including packing materials, glues, grease, fabrics and other items.

### **Oriental Cockroach** *(Blatta orientalis)*

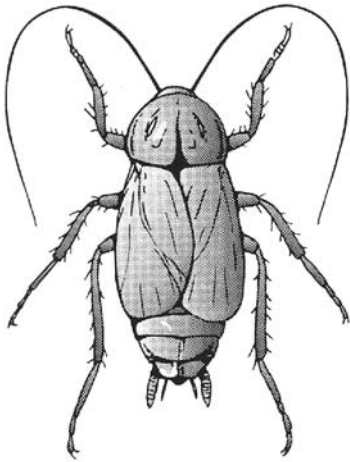

**Male Oriental cockroach**

Adult Oriental cockroaches are shiny black or very dark brown. Males are about 1 inch long, and females slightly longer. Females do not have wings, but they do have “wing pads.” Males have short, wide wings that cover about 1/2 to 3/4 of the abdomen. Neither sex can fly.

The female glues her egg case to a surface in a protected area soon after it forms. She usually produces eight egg cases during her life span. Nymphs develop slowly during the spring and summer. By fall, they are nearly full grown. Large nymphs overwinter with little feeding and molt to the adult stage in the spring. Adults live only a few months.

Oriental cockroaches are widespread in the United States. They can tolerate cool conditions, and are often active in the early spring. This species lives both indoors and outdoors. It is strongly associated with excess moisture. Oriental cockroaches often live in sewers and enter buildings through drains and small cracks. Once inside, Oriental cockroaches infest crawl spaces and basement areas. Drains and

cracks may provide an escape for these pests when threatened by indoor control efforts such as fumigation.

Like other cockroaches, the Oriental cockroach feeds on a wide range of stored products including foods, fabrics, glues, grease, soap and other items. They also produce frass that can stain many items.

### **Brownbanded Cockroach** *(Supella longipalpa)*

The brownbanded cockroach is similar in size and color to the German cockroach. However, the brownbanded cockroach has two light-colored bands running from side to side just below the pronotum, at the base of the wings. The pronotum is dark brown with light sides. It does not have stripes. The female’s wings are slightly shorter than her body, and the tip of her abdomen is rounded. By comparison, the male’s wings are longer than his tapered abdomen. Females measure 1/2 inch long. Males tend to be slightly smaller. Male brownbanded cockroaches can fly, but usually move by running on walls and floors. Females cannot fly.

Females carry their small egg case for about 36 hours. Then, they glue it to a surface in a protected place. The number of eggs per case ranges from 18 to 20. Each female will produce about 14 egg cases during her life. The average time for development from egg to adult is 150 to 160 days.

Unlike other cockroaches, brownbanded cockroaches can withstand somewhat dry environments. This allows them to move into all areas of a building or home. You will often find them close to the ceiling or above ceiling tiles.

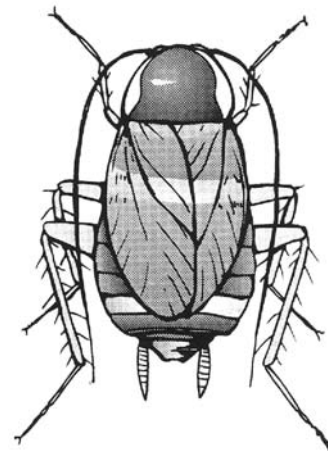

**Female brownbanded cockroach**

Brownbanded cockroaches also prefer buildings that maintain high temperatures. They favor areas near stoves or around electric motors of machinery and appliances. This species does not normally infest food establishments.

Brownbanded cockroaches are often difficult to control. Because this species is not attracted to moisture, moist or gel baits provide little relief. In addition, their high habitats (on ceilings or above ceiling tiles) are difficult to reach with pesticide sprays. For these reasons, fumigation is often the only choice for large infestations.

## Control

The first step in controlling cockroach infestations is to eliminate food, water and harborage sites (such as cracks and crevices). Poor sanitation, scraps left over from lunches, empty soda bottles and dirty appliances will support cockroach populations in office buildings and factories. In particular, keep shipping and receiving areas free of food and water sources. These areas are where cockroaches gain access to buildings.

Favorite cockroach “hideouts” include:

- Under sinks
- Behind baseboards
- In and under stoves and refrigerators
- In, behind and under built-in shelves and cabinets
- Under trash
- In washing machines
- Around machinery in warehouses
- In and under pallets, cardboard boxes and stored paper goods
- In cracks and crevices in concrete, brick or block walls

When chemical control is necessary, baits and nonfumigant pesticides should be the first line of attack.

While fumigation is rarely used to control cockroaches, it may be necessary in the following situations:

- When infestations are too severe for other pesticides (for example, mobile homes that have cockroaches living in walls, ceilings, under floors and in other hard-to-reach areas)
- When a high-value product is at stake

- In a storage facility where product turnover is too fast for baits to kill cockroaches before the next shipment

## Rodents

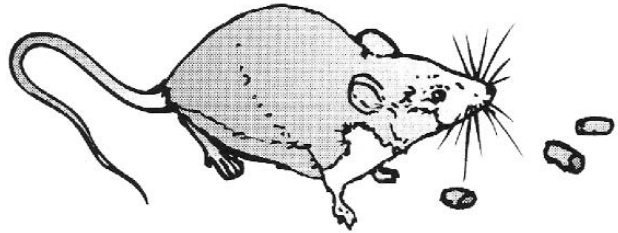

Mouse

Rodents are major pests of stored products. Four large, gnawing teeth (two on top and two on bottom) characterize these small to medium-sized mammals. Rodents include mice, squirrels, rats, groundhogs, gophers and similar mammals.

The most serious rodent pests causing damage to stored products in Arkansas are the Norway rat (*Rattus norvegicus*) and the house mouse (*Mus musculus*). The roof rat (*Rattus rattus*) is an occasional problem as well. Rodent pests consume and contaminate large amounts of stored products. One rat can consume about 50 pounds of grain a year and can contaminate much more. Rodents also gnaw holes in wood, rubber, wiring and insulation. Their burrows can undermine structures. Another common rodent pest, the groundhog (*Marmota monax*), causes damage by burrowing. Mounds of earth excavated from the burrows present a hazard to farm equipment, horses and riders. Groundhogs also damage fruit trees and ornamental shrubs when they gnaw or claw woody vegetation.

## Control

Control rodents with a combination of sanitation, exclusion and trapping. Nonfumigant rodenticides such as baits can also maintain populations at low levels. However, over a large area such as in a warehouse, fumigants may be the most cost-effective way to reduce rodent numbers.

Accurate identification of pests is vital for control methods of any type to be effective. Once you decide fumigation is the best way to control the pest, your knowledge of methods and application procedures comes into play.

# Test Your Knowledge

**Q. Why are cockroaches considered pests?**

- A. Cockroaches carry bacteria that cause disease. Many people are allergic to them, and they can cause some types of asthma. They have an unpleasant odor. They can stain and contaminate a number of stored products.

**Q. Describe the general body form of a cockroach.**

- A. Cockroaches have flattened bodies and long, slender antennae. When seen from above, the head is covered by a shieldlike pronotum. Most adult cockroaches have wings.

**Q. Describe the life cycle of cockroach.**

- A. Cockroaches develop by gradual metamorphosis. Females produce eggs in cases. In some species, the female carries the case on her abdomen until the young are ready to hatch. These females retreat to a protected spot while carrying a case. In other species, the egg cases are deposited in an out-of-the-way place soon after they form. Nymphs hatch from the eggs and gradually develop into mature adults.

**Q. What environmental conditions do most cockroach species prefer?**

- A. Warm, moist conditions.

**Q. Which species of cockroach can withstand dry conditions?**

- A. The brownbanded cockroach.

**Q. Which species of cockroach does not normally infest food establishments?**

- A. The brownbanded cockroach.

**Q. If a product is stained by cockroach frass, what two species would you suspect?**

- A. The American cockroach and the Oriental cockroach.

**Q. Which of the four species of cockroaches discussed in this manual is the largest in size?**

- A. The American cockroach.

**Q. Which of the four species of cockroaches discussed in this manual is the most common and widespread structural cockroach pest?**

- A. The German cockroach.

**Q. Describe three situations in which fumigation may be necessary to control cockroach infestations.**

- A. 1. When infestations are too severe for other pesticides (for example, mobile homes that have cockroaches living in walls, ceilings, under floors and in other hard-to-reach areas).  
2. When a high-value product is at stake.  
3. In a storage facility where product turnover is too fast for baits to kill cockroaches before the next shipment.

**Q. When is fumigation considered a method to control bed bugs?**

- A. When you need to treat an area occupied by residents who are sensitive to pesticide sprays. Examples include nursing homes and day care centers.

**Q. In what ways do rodents damage stored products?**

- A. By consuming and contaminating them. One rat can consume about 50 pounds of grain a year and can contaminate much more. Through their saliva, feces and urine, rodents can introduce pathogens that are harmful to humans and livestock.

**Q. Name two types of rodents that commonly damage stored products.**

- A. 1. The house mouse.  
2. The Norway rat.

# Pathogens and Pests in the Soil

Farmers, nursery operators and other growers battle with an enemy underground. Fumigants are one of many weapons used to keep crops healthy. In Arkansas, you can use soil fumigants to control nematodes, weeds and soil-borne pathogens such as bacteria and fungi. Fumigants are useful in greenhouses, nurseries and fields where peanuts, tobacco, cotton, vegetables, ornamental plants, turfgrass, small fruits and nuts are produced.

Although fumigants can kill a broad range of insects, pathogens, weeds and other organisms that live in the soil, they are not universally effective. Soil fumigants are most often used to control plant diseases, nematodes and weeds. Other control methods are usually more effective for soil insects.

When targeting nematodes and diseases, soil fumigation will usually only control root and lower stem problems. It is rarely effective on diseases and problems that attack leaves and upper stems. This is because the pathogens and pests that cause these problems usually do not come from the soil. Root and stem disease problems cause a range of symptoms. Infected plants usually display poor, uneven growth. They may wilt even though plenty of water is available. They may have poor color when adequate fertilizer is present. If you dig up infected plants, their roots are usually smaller than normal, distorted and/or rotten. Infected fields often have patchy symptoms – the plants in one area of a field may show more distress than the plants in another area of the same field.

Fumigants are often used to control root and stem problems because of their broad range of effectiveness against pathogens and pests. For example, when nematodes and soil insects feed on plant roots, they often spread diseases caused by fungi, bacteria and viruses. By controlling nematodes and soil insects in addition to pathogens, fumigation can reduce disease problems more than other control methods.

Fumigating the soil will also kill most annual weed seeds. However, some perennial and small, hard-seeded weeds will survive soil fumigation.

As with fumigation of raw commodities, correct identification of the target pest is critical. It will help you select the best control

method for the situation. Identification of soil insects and plant pathogens can be difficult because they are often hard to find. Instead, you may have to identify these pests by matching the types of damage they cause with what you observe where the problem(s) occurs. Correct identification of nematode problems, on the other hand, often requires a “nematode assay.” A laboratory performs this type of procedure. Weed identification takes practice, but these pests are easy to see and sample during the growing season.

If you need help with identification or diagnosis, contact you local University of Arkansas Division of Agriculture county Extension agent. You may also need to collect samples (insects, soil and/or plant tissue) and send them to the diagnostic laboratory.

## Nematode Pests

Nematodes are tiny, transparent roundworms that usually live in soil. Because most nematodes are microscopic, it is easy for people to spread them. You can move nematodes from place to place in soil and on footwear, tools and equipment.

Nematodes are very abundant. A bucket of soil may contain millions of them. Most species are free-living and harmless. Some are even beneficial because they attack other pests. Nematode parasites of insect pests are an example. However, many nematodes are parasites of plants and animals. A plant parasitized

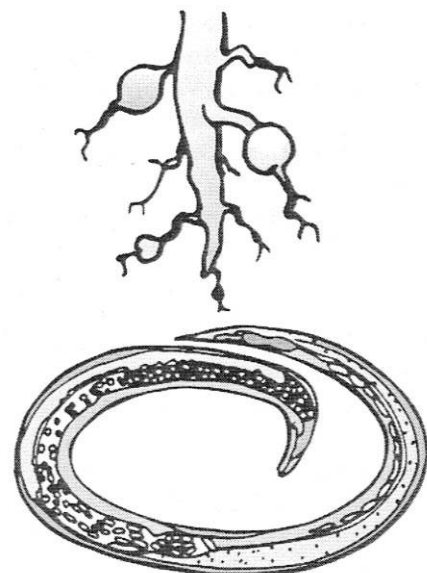

Typical nematode and nematode damage

by nematodes often displays slow and uneven growth. Eventually the plant may decline. Nematode-infected plants that are also being attacked by a disease or are under severe environmental stress can die.

Plant parasitic nematodes have a hollow, needlelike tooth called a “stylet.” They insert their stylets into host plant cells and feed on the contents. Some plant-infecting nematodes lay eggs, develop and feed inside a host plant. Other types feed outside the host and lay eggs in the soil. Some do both.

Different species of nematodes attack different plant parts. Nematodes that parasitize roots cause plant stunting and poor growth by reducing the size and effectiveness of the root system. Root-knot nematodes (*Meloidogyne* spp.) remain inside roots for most of their life cycle. Infected roots swell to form galls where adult females are located. Cyst nematodes (*Globodera* spp.) develop inside roots, but adult females are barely visible as “cysts” on the surface of infected roots. Lesion nematodes (*Pratylenchus* spp.) wander in and out of host roots, feeding and damaging root cells as they go. Others, like dagger (*Xiphinema* spp.) and spiral nematodes (*Helicotylenchus* spp.) nematodes can also transmit viral diseases to plants. The foliar or spring crimp nematode (*Aphelenchoides* spp.) lives within the leaf tissues of many indoor plants. It kills leaf tissue, resulting in brown lesions on older leaves. Regardless of the type of nematode, plants weakened by nematode infestations are often more susceptible to other infectious diseases.

Sometimes you can identify nematodes by the type of damage that they cause. In other cases, you will need to send root and soil samples from several locations in an infected field to a laboratory. There, experts can identify and count the nematodes. Base your control efforts on the number and types of nematodes that they find.

## Control of Nematode Pests

Crop rotation and the use of resistant plant varieties are the best methods to control nematodes. Planting the same crop year after year in a field allows nematode populations to build to damaging levels. Alternating (rotating) crops that are susceptible to nematodes with crops that are not susceptible helps keep nematode populations low enough that they do not cause significant damage. Many plants and crops also have varieties that resist nematode parasitism. By planting these varieties, you can often increase yields and reduce nematode

populations most effectively. This is especially true when you rotate the fields as well.

You can also prevent nematode problems by practicing good sanitation. Good sanitation includes thoroughly washing tools and equipment before use. Also, avoid using irrigation water from sources into which infested soil might drain. Do not reuse growing media from greenhouses and nurseries. Fumigate or steam soil and growing media stored outside before bringing it inside for use. If nematodes do infest a field or soil in a greenhouse, you can often reduce damage by keeping plants healthy and free from external stresses. For example, be sure that plants have an adequate supply nutrients and water. When working with annual crops, prevent buildup of nematode populations by destroying crop residues as soon as possible after harvest.

When nematode levels get high, you may need to treat the soil with steam, nonfumigant nematicides or fumigants. Keep in mind that most nonfumigant and fumigant nematicides also kill insects – both beneficial and harmful. See Unit 4 for more information on alternatives to fumigation.

## Plant Diseases

Plants get sick just as people do. These problems are often caused by microscopic organism called “pathogens” that live in the environment surrounding plants. Pathogens may damage susceptible plants by damaging their roots and stems. If the disease damage is severe enough, the plant could die. Fumigants are one of many tools you can use to prevent this damage by eliminating the pathogen.

## Disease Development

Plant diseases are the result of a battle between the plant and the pathogens that surround it. Although pathogens are often present around plants, they are capable of causing disease only under certain conditions. Scientists who study plant diseases illustrate the relationship between the pathogen, the plant (host) and the environment by what they call the “disease triangle.”

The right type or strain of a pathogen must contact a susceptible variety of plants under just the

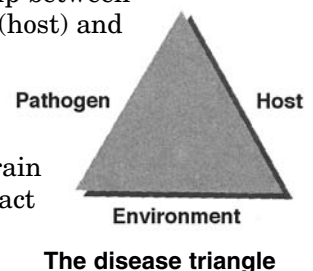



right environmental conditions for disease to occur. When this happens, you will often need to intervene to prevent damage.

Bacteria and fungi are the two main types of plant pathogens that live in the soil.

## Bacterial Diseases of Plants

Bacteria are single-celled, microscopic organisms. Disease-causing bacteria usually get their food energy from the organisms that they infect. Most soil bacteria require some sort of opening in a plant surface to enter. However, other bacteria produce chemicals called “toxins” that can poison plants even when the bacteria do not actually infect them. Like nematodes, soil bacteria can spread in soil and on footwear, tools and equipment. They can also spread in water runoff through and from infested fields.

Bacterial infections on leaves often appear as oily, greasy or water-soaked spots. Symptoms on stems and roots include rotten areas (often with a sour smell), cankers and wilting. Rotten areas caused by bacterial diseases are usually very moist. Sometimes a viscous, slimy mass will be oozing in and around infected tissues. Wilting caused by bacterial infection of roots and stems often occurs on just one side of an infected plant. Some bacterial diseases that affect leaves are “localized.” This means that the bacteria are confined to spots on leaves and stems. If left unchecked, most bacterial diseases spread throughout their host plants, often killing them.

Many types of bacteria live in soil. Only a few cause plant disease. Accurate identification of bacterial diseases can be difficult because symptoms are often similar to those caused by

other pathogens. Contact your local Extension agent for help in making a diagnosis. This will save time and ensure that you use the right control option for the problem at hand.

## Fungal Diseases of Plants

Fungi cause more plant diseases than any other type of infectious agent. Fungi are simple, often microscopic organisms that cannot make their own food. They obtain what they need by decomposing dead plant or animal matter or by infecting living things. Unlike most bacteria, fungi do not usually need an opening or wound through which to enter plants.

Most fungi produce reproductive spores that function like the seeds of flowering plants. Each spore can start a new fungal infection. Spores can lie dormant for many years. In this way, they can survive periods when the environment is unfavorable or when a susceptible host is not present. Although fungal spores are microscopic, some fungi that live in soil produce other structures that can be seen with the unaided eye. Like nematodes and soil bacteria, soil fungi are frequently spread on footwear, tools and equipment and in water runoff from infested fields.

Fungi can infect plant roots and stems at most stages of their life cycle. Moist soil conditions favor infection. Like bacterial wilt, fungal wilt diseases can spread throughout an infected plant, eventually killing the plant. Many soil fungi cause “damping-off” diseases. Damping-off kills young plants just before or after the seedlings emerge from soil. Larger, older plants may survive fungal attack but often show reduced growth and visible damage on their roots and stems. This is particularly true on areas of the plant that are close to the soil surface.

Fungi that infect plant roots and stems are hard to detect. The symptoms they cause are often similar to those caused by bacteria. However, fungal root and stem rot can be either wet or dry. Root and stem rots caused by soil fungi usually cause the entire plant to wilt, compared to the one-sided wilts associated with bacteria. Because accurate diagnosis often requires growing the pathogen in a laboratory or the use of new diagnostic assays, contact your local Extension agent if you are not sure of the cause of a root or stem problem. Some soil fumigants control both fungal and bacterial

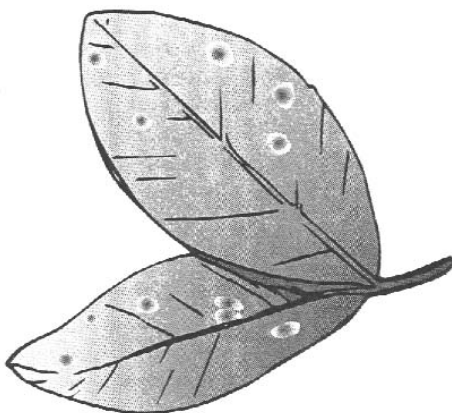

Early leafspot on a plant

diseases. Others are only effective against one or the other. An incorrect diagnosis can lead you to use the wrong pesticide. This wastes time and money and puts unneeded chemicals into the environment.

## **Viral Diseases of Plants**

Viruses are so small that you cannot see them using an ordinary light microscope. Viruses do not need oxygen as do most living things. Nor do they require nutrients for energy. Viruses are composed of chemical compounds called nucleic acids (RNA or DNA) surrounded by a “protein coat.” Like bacteria, viruses require an opening or wound in order to enter a plant. Once in a plant cell, a virus takes over the function of that cell. It forms new viruses at the expense of the normal growth and health of the cell. Viral diseases cause yellowing and burning of leaves, distorted plant growth, stunting and decline and sometimes death of plants. Currently, there are no pesticides available to treat virus-infected plants.

Although viral diseases are usually associated with symptoms on above-ground plant parts, some viral diseases attack plants through the roots. For example, “ring spot” diseases cause leaf spots shaped like rings. However, the viruses that cause these diseases can be introduced into plants by nematodes that feed on plant roots. The nematodes that transmit these viruses do not actually enter plant roots. Instead, they introduce virus particles into the plant as they feed on the root surface. You can use chemicals that control nematodes (nematicides) in some crops to prevent or minimize some viral diseases. These work by reducing the number of nematodes in the soil that might transmit these viruses.

## **Control of Plant Diseases**

Understanding the factors that favor or cause plant diseases will help you plan a management program. Environmental conditions such as compacted soil, too much or too little water and temperature extremes can stress plants and make disease problems worse. By changing cultural practices to favor the plant over the pathogen, you can often prevent or reduce disease. Good sanitation can also help you avoid plant disease by keeping the plant away from disease-causing organisms. Keep

tools and equipment clean to reduce the odds of transferring soil-borne pathogens from one field to another. Adjust planting sites and dates and rotate crops to reduce the chances that soil pathogens will contact roots and stems. Destroy crop debris promptly to decrease the number of pathogens that carry over to future crops.

Another way to reduce pathogen buildup and damage to crops is to plant disease-resistant crop varieties. This is often the most effective method available to reduce disease levels. However, resistant varieties may not have some of the desirable characteristics (yield, quality, appearance, etc.) that more susceptible varieties possess. In these cases, you may need to use a pesticide. See Unit 4 for more information on alternatives to fumigation.

There are many types of fumigant and nonfumigant pesticides available to control soil-borne pathogens. Use fumigants when you need to target root diseases caused by nematodes or bacteria or when a number of different soil organisms are present at damaging levels. Fumigants that control more than one disease or pest problem are called “multipurpose fumigants.” You will usually need to apply fumigants several weeks before planting. Otherwise, fumigant residues may damage emerging crops. Base your control decisions on the amount of disease that occurred in previous years.

## **Weeds**

You can also use soil fumigants to control weeds. A “weed” is simply a plant growing where it is not desired. For example, a corn plant growing in a soybean field is a weed. Weeds compete with desirable plants for water, nutrients, light and space. Some weed species harbor insects and diseases that can move to and infest crop plants. Sometimes weeds pose a public safety hazard. For example, plants like water hemlock, horse nettle, black nightshade and jimsonweed are toxic. They are a danger to livestock and people.

Most of the plants that are considered weeds are very hardy. They are also good competitors. Many weeds produce a large number of seeds. The seeds of some species may remain viable for long periods. In addition, many weeds have good ways to spread their seeds – by wind, animals, or by floating in water.

## Common Weed Crops: Crabgrass and Bull Thistle

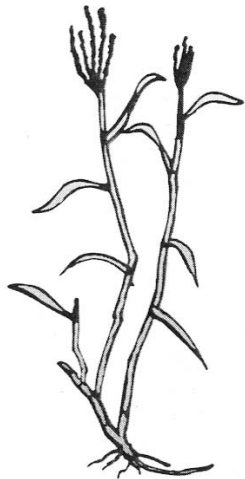

Crabgrass

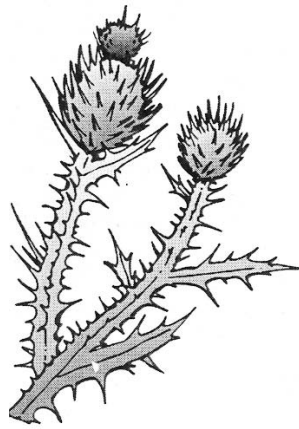

Bull thistle

Before planting a crop, you can use fumigants to control weeds. Other herbicides that are applied after planting may damage the crop. Fumigants are also helpful when there is no practical way to apply other herbicides correctly.

### Control of Weeds

There are many ways to control weeds. Some options include:

- Tilling
- Hoeing
- Hand weeding (when practical)
- Use of mulches and landscape fabrics
- Crop competition
- Crop rotation
- Fire
- Biological control
- Chemical control (including fumigation)

Generally, the best management program involves a combination of methods. When pesticides are required, choose between nonfumigant herbicides and fumigants. Herbicides are pesticides that kill or inhibit the growth of undesired plants. Nonfumigant herbicides are available as solids and liquids. They affect only plants and germinating seeds. Some nonfumigant herbicides are more effective at a certain stage in the plant's life cycle. On the other hand, soil fumigants that kill weeds will kill most weeds in the soil, including most dormant weed seeds. They are effective at all stages in the plant's life cycle. Use soil fumigants when

you need to control all types and stages of weeds. Base your decision about whether to fumigate on the type and number of weeds that were present in the field in past years.

*NOTE: The soil fumigants that kill weeds will control most types of weeds. Fumigants do control most weeds. However, deep-rooted perennials are more difficult to control than annuals. In addition, some perennial and small, hard-seeded weeds such as white clover can survive soil fumigation.*

### Insect Pests

Soil fumigation controls several insect pests that live in the soil and injure crops. Examples include wireworms, white grubs, rootworms, ants and cutworms.

#### Wireworms

Wireworms are the larvae or "grubs" of various species of click beetles. These grubs have distinctive segmentation and often look like pieces of copper wire. Wireworms feed on the roots and in the piths of many plants. Wireworm damage reduces plant vigor and provides openings for soil-borne pathogens.



Wireworm

#### White Grubs

White grubs are the larvae of various species of scarab beetles. They feed on the roots of many different plants, particularly sod. The larvae of one type of scarab beetle, the green June beetle, can cause serious problems in plant beds by uprooting seedlings.

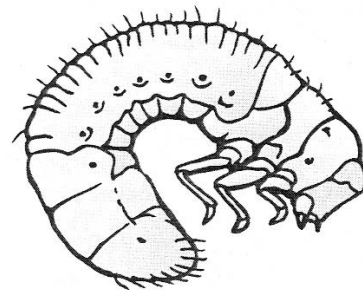

White grub

## Cutworms

Cutworms are caterpillars that “cut off” the stems of plants and feed on their root stalks and leaves. Adult cutworms are medium-sized gray to brownish moths that are active at night. The moths of some species emerge in the early spring, mate and lay their eggs on plants where the larvae develop. Other species overwinter as larvae. When the land is plowed, the larvae in the soil are active and will attack young crop plants that are seeded or transplanted into the field.



Cutworm

## Control of Insect Pests

Early plowing helps to reduce wireworm and cutworm populations. Various grasses and early

spring weeds are favorable egg-laying sites for cutworm moths. Crop rotation helps control white grubs and reduce problems with wireworms and cutworms. Fall plowing that exposes white grubs to predation by birds also helps reduce grub infestations. Several insecticides applied to the soil provide effective control of soil insects at much lower costs than soil fumigation. See Unit 4 for more information on alternatives to fumigation.

Do not use soil fumigation solely for insect control. The control of these and other insects is a side benefit of fumigation’s main purpose: to control nematodes, soil-borne pathogens or weeds. In-row soil fumigation for nematodes provides good control of soil insects, but it will not kill insects outside the treated zone. Some insects are able to move to avoid the fumigant. In addition, nonfumigant insecticides usually provide effective control of insect pests at much lower costs than do fumigants.

# Test Your Knowledge

**Q. Describe the typical symptoms caused by root and stem diseases.**

- A. Infected plants usually display poor, uneven growth. They may wilt although plenty of water is available. They may have poor color when adequate fertilizer is present. If you dig up infected plants, their roots are usually smaller than normal, distorted and/or rotten. Infected fields often have patchy symptoms – the plants in one area of a field may show more distress than the plants in another area of the same field.

**Q. How can people spread nematodes, pathogens and weed seeds from one field to another?**

- A. In soil and on footwear, tools and equipment. These pests can also travel in water runoff from infested fields.

**Q. What portion(s) of a plant do nematodes typically infest/damage?**

- A. Different species of nematodes attack different plant parts. Most focus on the roots. Root-knot nematodes remain inside roots for most of their life cycle. Cyst nematodes develop inside roots, but adult females appear as “cysts” on the surface of infected roots. Lesion nematodes wander in and out of host roots, feeding and damaging root cells as they go. Others, like dagger and spiral nematodes, feed on roots from outside the root system. The foliar or spring crimp nematode lives within the leaf tissues of many indoor plants.

**Q. Describe the typical symptoms of a plant parasitized by nematodes.**

- A. Plants are often stunted, displaying slow and uneven growth.

**Q. Explain how crop rotation and the use of resistant plant varieties help to control nematode damage.**

- A. Planting the same crop year after year in a field allows nematode population to build up damaging levels. Alternating (rotating) crops helps keep nematode populations low enough that they do not cause significant

damage. Many plants and crops have varieties that resist nematode parasitism. By planting these varieties, you can often increase yields and reduce nematode populations. This is especially true when you rotate the fields as well.

**Q. Describe the typical symptoms caused by bacterial infections on plants.**

- A. Bacterial infections on leaves often appear as oily, greasy or water-soaked spots. Symptoms on stems and roots include rotten areas (often with a sour smell), cankers and wilting. Rotten areas caused by bacterial diseases are usually very moist. Sometimes a viscous slimy mass will be oozing in and around infected tissues. Wilting caused by bacterial infection of roots and stems often occurs on just one side of an infected plant.

**Q. What is the best way to identify bacterial and fungal infections on plants?**

- A. Accurate identification of bacterial and fungal infections can be difficult because their symptoms are often similar. Contact your local Extension agent for help in making a diagnosis. This will save time and ensure that you use the right control option for the problem at hand.

**Q. What soil condition(s) favors fungal infection of plants?**

- A. High moisture levels.

**Q. What is the difference between a plant wilting from a bacterial infection and a plant wilting from a fungal infection?**

- A. Root and stem rots caused by soil fungi usually result in wilting of the entire plant, compared to the one-sided wilts associated with bacteria.

**Q. Describe several nonchemical ways to control plant diseases.**

- A. Environmental conditions such as compacted soil, too much or too little water and temperature extremes can stress plants

and make disease problems worse. By changing cultural practices to favor the plant over the pathogen, you can often prevent or reduce disease. Good sanitation can also help you avoid plant disease by keeping the plant away from disease-causing organisms. Keep tools and equipment clean to reduce the odds of transferring soil-borne pathogens from one field to another. Adjust planting sites and dates and rotate crops to reduce the chance that soil pathogens will contact roots and stems. Destroy crop debris promptly to decrease the number of pathogens that carry over to future crops. The use of disease-resistant crop varieties may also control plant diseases.

**Q. Describe the typical symptoms of a plant infected with a virus.**

A. Viral diseases cause yellowing and burning of leaves, distorted plant growth, stunting and decline, and sometimes death.

**Q. How can fumigant and nonfumigant pesticides prevent or minimize viral diseases on plants?**

A. Currently, there are no pesticides available to treat virus-infected plants directly. However, because nematodes transmit some types of viruses to plants, pesticides that control nematodes can reduce the number of nematodes in the soil, thus, reducing the incidence of disease.

**Q. What types of problems do weeds cause?**

A. Weeds compete with desirable plants for water, nutrients, light and space. Some weed species harbor insects and diseases that can move to and infest crop plants. Weeds can also be a danger to livestock and humans (for example, toxic water hemlock, horse nettle and black nightshade).

**Q. When are fumigants a good choice to control weeds?**

A. Before planting a crop, you can use fumigants to control weeds. Other herbicides that are applied after planting may damage the crop. Fumigants are also helpful when there is no practical way to apply herbicides correctly.

List several nonchemical options to control weeds.

These include:

- Tilling
- Hoeing
- Hand weeding (when practical)
- Use of mulches and landscape fabrics
- Crop competition
- Crop rotation
- Fire
- Biological control

**Q. What is the main advantage of fumigants over nonfumigant herbicides?**

A. Fumigants kill most dormant weed seeds. Nonfumigant herbicides do not usually kill viable but dormant seeds.

**Q. What insect pest damages plants by cutting off the stems and feeding on the root stalk and leaves?**

A. Cutworms.

**Q. When should you use fumigation to control insect pests?**

A. When it is a supplemental effect from applications targeting weeds, pathogens or nematodes. Do not use soil fumigation solely for insect control.

# Monitoring and Sampling in Raw Agricultural Products and Soil

Inspect for pests before they become a problem, and you will save time and money. Sampling will tell you the physical condition of your commodity or soil, and which and how many pests are present. It will also help you evaluate the effectiveness of previous control programs and allow you to take corrective measures before fumigation is required. Be thorough and use appropriate sampling equipment. Know where, how and at what intervals you should sample.

## Detecting Pest Problems – Raw Products

To manage stored-grain insects effectively, always examine the grain before it is unloaded and moved into storage. Check grain for insects, moisture content and sour or musty odors. Use manual or hydraulic probes to withdraw grain samples from incoming loads. Sift and check these samples for insects.

**Table 2-1. Number of live insects required for Federal Grain Inspection Service designation as “infested”**

Grain	Insect Density Per Kilogram of Grain
Wheat, rye, triticale	<ul style="list-style-type: none"> <li>• More than one live weevil, or</li> <li>• One live weevil plus any other live insect pest, or</li> <li>• No live weevils, but two or more other live insect pests</li> </ul>
Corn, barley, oats, sorghum	<ul style="list-style-type: none"> <li>• More than one live weevil, or</li> <li>• One live weevil plus five or more other live insect pests, or</li> <li>• No live weevils, but ten or more other live insect pests</li> </ul>

Once grain has been stored, it is important to inspect bins regularly. Sample stored grain at 30-day intervals until it cools to less than 20°C. By taking samples, you can measure the grain temperature and moisture and detect any new insect problems. If there are “hot spots” (temperatures greater than 10°F higher than the rest of the grain), collect samples from these areas. Hot

spots indicate a high moisture content that favors insect and fungus activity. Determine the moisture content of your commodity and the presence of any insects. It is especially important to check for insects in samples from the grain surface and from areas where fines have collected. Infestations often begin in these locations.

Table 2-2 lists the minimum number of samples you should take when monitoring round bins. If temperatures are unusually high in certain spots, collect samples from those areas. Determine the moisture content and presence of any insects.

**Table 2-2. Minimum number of samples for determining temperature, moisture and insect levels in round bins**

Bin Height	Temperature Probes		Moisture and Insect Determinations	
	Shallow*	Deep*	Shallow*	Deep*
Less than 24 feet	2	3	3	5
Greater than 24 feet	2	5	3	10

*\*Take shallow samples at or just below the surface of the grain. Take deep samples from various depths determined by the sampling equipment and your ability to probe the grain mass. Be sure to take one shallow sample and one deep sample from the center of the grain mass. This is especially important if fines are concentrated in the central core.*

## Sampling Tools

Several types of probes are available for sampling grain. Industry suppliers can give you instructions for using these devices.

- Partitioned grain trier (“probe”) – This tool captures insects in stacked compartments. Suppliers sell 3-, 5-, 10- and 12-foot models. Always sample the center surface of the storage bin and at least two other locations near the surface. To operate the grain trier, insert it into the grain at a 10° angle with the compartments closed and facing upward. Once the trier is in the grain, open the compartments to take a grain sample. Then, shut the compartments and remove the trier from the grain. Place the samples from each section in a plastic bag or other container. Sieve each sample and check for insects.
- Deep-bin or deep-cup probes – Use these probes to collect samples from greater

depths within a grain mass. They extend up to 15 feet below the surface. The sample cup is attached to the end of a metal probe and inserted closed into the grain mass.

- Vacuum samplers or power probes – These tools allow you to collect samples from depths greater than 10 to 15 feet. A modified shop vacuum can collect samples from depths as great as 20 to 30 feet. Hydraulic or mechanically powered probes can collect samples from depths as great as 100 feet.

## Traps

Traps are another way to monitor insect activity in stored grain. Because traps depend on insect movement, they are not effective when grain or air temperatures are below 50°F. At these temperatures, insects are not active.

- Plastic probe or pitfall traps – These traps consist of a long, clear plastic cylinder with perforations drilled through the upper part. Insects crawl through the perforations and drop through a funnel into a lower catch-tube. See product literature for more complete instructions. Pheromones and food baits often enhance collections in these traps.

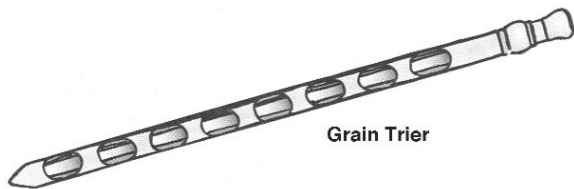

- Corrugated cardboard trap – This trap holds an oil lure that attracts and kills insects that are active where the trap is placed. You can use these traps on the surface of a grain mass to detect insect presence. They are also effective around bagged seeds or feeds in warehouses.

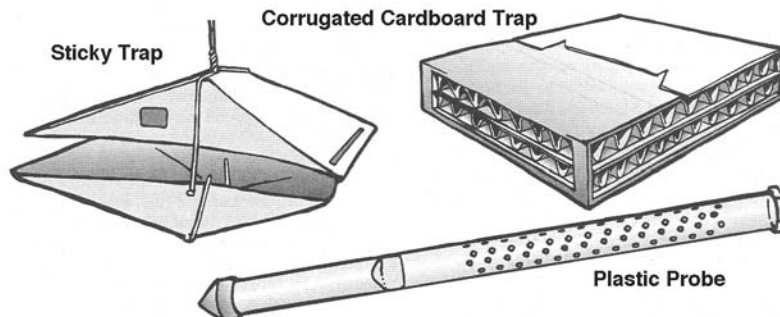

- Paper sticky traps – Baited with attractants, paper sticky traps allow you to monitor the flight of the lesser grain borer, cigarette beetle and several other pests in warehouses and processing plants.

If you need help with insect identification contact your local Extension agent

## Detecting Pest Problems – Soil

Plant managers must look for characteristic signs and symptoms to diagnose plant health problems. Detecting pest problems in soil involves careful and regular observation.

Living and nonliving factors can harm plants. In fact, nonliving factors are the most common cause of problems. Nonliving or “abiotic” conditions, such as too much or too little moisture or fertilizer, tend to cause uniform problems over large areas. Pesticide carryover from previous growing seasons or pesticide drift can also affect plants uniformly over large areas. Living or “biotic factors include diseases, insects and nematodes. Problems caused by these organisms rarely affect every plant in a field. Instead, they tend to concentrate in spots or areas within a field or planting. However, biotic problems can spread from small areas to attack large numbers of nearby plants, sometimes very quickly. Often both living and nonliving stress factors work together to cause plants to decline.

## Plant Samples

To identify the cause of a problem, you will often need to take plant samples. Collect plant parts that display characteristic signs and symptoms. Check for damage to roots, leaves or stems. Sometimes you can see pests or pathogens on or near damaged plants with the



unaided eye. When this is the case, the pest or the visible parts of the pathogen (for example, fungal spores or bacterial ooze are “signs” of disease). A symptom is a reaction of a plant that is suffering from some sort of disease, disorder or predation. Symptoms may include slow or irregular growth, wilting or even death. Roots and stems may be limp, mushy or abnormally dark in color. Discolored and abnormal areas may be visible along stems near where they emerge from the soil. Leaves may be chewed, discolored or have brown tips, margins, spots or scabs. Other symptoms are not visible unless the affected plant part is magnified. Some conditions have specific, unique symptoms and signs that are easy to identify. More commonly, however, it takes an expert to determine exactly what is causing the damage. If you need help identifying the cause of a plant health problem, contact your local University of Arkansas Division of Agriculture county Extension agent. You can also use an independent laboratory (available in some areas). Send samples of the advancing edge of the damaged areas on each plant – roots, stems and leaves – that include healthy as well as damaged tissue. Wrap samples in moist paper towels or newspaper – not in plastic – and send them by an overnight carrier to ensure freshness.

## Soil Samples

Soil samples are primarily used to diagnose and predict damage caused by nematodes. You will most often use these samples to perform two types of tests:

- Diagnostic nematode assays – used to identify whether a nematode is the cause of a particular problem
- Predictive nematode assays – used to predict nematode populations before the planting season begins

Both assays are performed by laboratories. In some areas, independent laboratories are available.

## Diagnostic Nematode Assays

If you suspect nematodes as the cause of a plant health problem, you will need to submit a soil sample for a diagnostic assay. Because many nematodes spend part of their life cycle in the soil and part in plant roots, accurate counts of their numbers require both soil and plant samples. This will tell you whether the

nematodes are the cause of the problem. Collect soil samples around live, symptomatic plants with a common crop history soon after symptoms appear. Avoid collecting samples when the soil is extremely dry or extremely wet. Collect samples using a soil-sampling core or shovel. Remove vertical core samples of soil from the feeder root zone of affected plants. The depth of the feeder root zone varies among crops, but a 6-inch depth is usually adequate for most annual crops and turf. Take soil samples for ornamental and perennial plants to an 8-inch depth. When sampling soils for deep-rooted perennials (for example, trees), take samples from two or three depths (for example, 6, 12 and 24 to 40 inches deep).

## Predictive Nematode Assays

Predictive nematode assays identify nematode problems before the planting season begins or before the problems become severe. This can help you predict when pesticide use (including soil fumigation) is necessary. For annuals such as field crops, collect soil samples for predictive assays in the fall. Nematode populations are usually highest at the end of the growing season and decline as the soil temperature drops. For turf and ornamentals, collect and submit soil samples for predictive assays before planting.

When sampling for both diagnostic and predictive nematode assays, it is important to take multiple soil samples. Nematode numbers usually change dramatically within a single field. If a field contains the same soil type throughout, collect at least 20 samples for each 4-acre section within a field. However, if a field consists of several soil types, divide the field into as many sections as there are soil types. Collect at least 20 samples for every 4 acres within a section. In a clean bucket, mix the 20 samples for each section. Place at least one pint of the soil mixture from each section into a nematode soil sample bag or plastic bag. Label the bag with the grower’s name, address, county, crop information and field or sample number. Protect the soil samples from extreme heat. Send them to a nematode diagnostic laboratory as soon as possible. Be sure to include background information such as the crop history with your samples. This will enable the technician to properly interpret the nematode counts.

Sampling pattern is important for all types of soil samples. This is because pathogens, pests

and nematodes tend to concentrate in certain areas within fields or plantings. The following guidelines suggest various sampling patterns or locations depending on the type of crop and pattern of planting:

- For solid-seeded crops, collect samples systematically throughout each section (Figure A).
- For row crops, collect samples from the feeder-root zone within the rows (Figure B).
- For established perennials, collect two samples from the dripline of each plant (Figure C).
- For individual plants such as trees or shrubs, collect ten samples – five near the trunk and five from the dripline (Figure D).

## Baiting and Trapping

Baiting and/or trapping soil pests is sometimes an effective way to monitor their activity. For example, one way to monitor wireworms is to place bait stations in fields after plowing. Use a mixture of wheat and corn under vermiculite to bait the trap. To sample cutworm populations, try placing clumps of clover in plowed fields. This may draw the cutworms to the clover, where you can count them.

If you need help with insect identification contact your University of Arkansas Division of Agriculture county Extension agent.

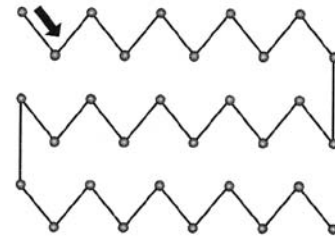

**Figure A. Sampling pattern for solid-seeded crops**

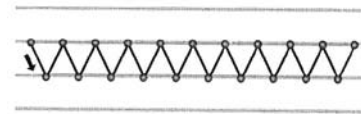

**Figure B. Sampling pattern for row crops**

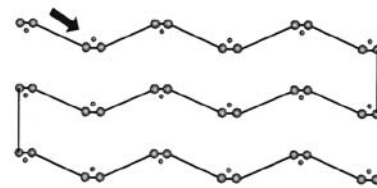

**Figure C. Sampling pattern for established crops**

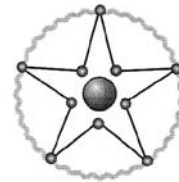

**Figure D. Sampling pattern for individual plants**

# Test Your Knowledge

**Q. What are “hot spots”? Why are they of particular concern in stored grain?**

A. Hot spots are areas in stored grain where temperatures are greater than 10°F higher than the rest of the grain. Hot spots indicate a high moisture content that favors insect and fungus activity.

**Q. Name several things you should look for or measure when sampling grain.**

A. 1. The presence of insects  
2. Sour or musty odors  
3. High grain temperatures  
4. High moisture levels

**Q. Why is it important to collect samples from the grain surface and areas where fines have collected?**

A. Insect infestations often begin in these locations.

**Q. If you needed to collect a sample 50 feet deep within a grain mass, what type of probe would you use?**

A. A hydraulic or mechanically powered probe.

**Q. What type of trap allows you to monitor the flight activity of insect pests?**

A. Paper sticky traps.

**Q. At what temperatures are insect traps often NOT effective? Why?**

A. Because many insect traps depend on insect movement, they are not effective when grain or air temperatures are below 50°F. Insect activity decreases below 50°F.

**Q. Describe the difference between how “biotic” and abiotic” factors cause plant health problems.**

A. Abiotic (nonliving) conditions such as too much or too little moisture or fertilizer tend to cause uniform problems over large areas. Pesticide carryover from previous growing seasons or pesticide drift can also affect plants uniformly over large areas. Biotic (living) factors include diseases, insects or nematodes. Problems caused by these organisms rarely affect every plant in a field. Instead, they tend to concentrate in spots or areas within a field or planting. However, biotic problems can spread from small areas to attack large numbers of nearby plants,

sometimes very quickly. Often, both living and nonliving stress factors work together to cause plants to decline.

**Q. What is the difference between a “sign” and a “symptom” of a plant disease?**

A. A sign of disease is a visible pathogen or part of a pathogen (for example, fungal spores, bacterial ooze). A symptom of disease is a reaction of a plant that provides a visual clue that the plant is suffering. Symptoms may include slow or irregular growth, wilting or even death.

**Q. Describe two different tests used to diagnose and predict damage caused by nematodes.**

A. Diagnostic assays are used to identify whether a nematode is the cause of a particular problem. Predictive nematode assays are used to predict nematode populations before the planting season begins or before problems become more severe. This can help you predict when pesticide use (including soil fumigation) is necessary.

**Q. Why is it important to take multiple soil samples when sampling for nematode assays?**

A. Diagnostic assays are used to identify whether a nematode is the cause of a particular problem. Predictive nematode assays are used to predict nematode populations before the planting season begins or before problems become severe. This can help you predict when pesticide use (including soil fumigation) is necessary.

**Q. Why is it important to take multiple soil samples when sampling for nematode assays?**

A. Nematode numbers usually change dramatically within a single field.

**Q. How would you sample the soil from a field that has several soil types?**

A. First, divide the field into as many sections as there are soil types. Collect at least 20 samples for every 4 acres within a section.

**Q. What sampling pattern would you use to collect soil samples around a single tree?**

A. Collect 10 samples – five near the trunk and five from the dripline.

# Unit 3. Characteristics and Effects of Fumigants

## Learning Objectives

After reading this unit, the reader will be able to:

- Describe several characteristics of fumigants
- Explain how these characteristics can affect how, when and where you use a particular fumigant
- Identify several factors that can affect fumigant performance during stored product and soil fumigation

Like all pesticides, several factors can affect how well a fumigant will work. These range from characteristics of the fumigant itself (boiling point, molecular weight, etc.) to external factors such as air movement, temperature, and applicator knowledge and skill. This unit will describe each of these factors. You will discover how small differences can have a big effect on fumigant performance and safety.

## Terms to Know

**Absorption** – When fumigant molecules penetrate into a material (commodity, soil or other item being fumigated).

**Adsorption** – When fumigant molecules stick to the surface of a material (commodity, soil or other item being fumigated).

**Aeration** – *Fumigant application*: The process of replacing fumigant-containing air or water with fresh air and/or water that contains little or no fumigant. Aeration must follow all fumigation operations.

**Boiling Point** – The temperature at which a liquid becomes a gas.

**Desorption** – The liberation or removal of a fumigant from treated surfaces and/or substances.

**Diffuse** – To spread or distribute, to move in all directions.

**Dosage** – The concentration of a fumigant (ounces, pm, etc.) times the exposure time (hours, minutes, etc.). The dosage requirements depend on the pest, the fumigant, the temperature, the rate of leakage (some leakage is inevitable), and many other factors.

**Equilibrium** – Even distribution. For example, a fumigant has reached equilibrium when there is an equal concentration of gas throughout a given structure.

**Field Capacity** – The moisture level of soil at which air has largely replaced water in soil macropores but not micropores. For example, at 50 percent field capacity, the total space between soil particles is shared equally by air and water, with most of the water being found in soil micropores.

**Inert** – Not reactive.

**Macropores** – The large spaces between soil particles in which air and water can move readily.

**Metabolism** – All chemical reactions that take place in a living thing. For example, insects metabolize food to produce energy.

**Micropores** – The small spaces between soil particles where little air movement occurs and water moves slowly. Plants absorb most of the water they need from soil micropores.

**Molecular Weight** – The sum of the atomic weights of all the atoms in a molecule. All fumigants have a unique molecular weight.

**Molecule** – The smallest particle of a substance that retains all of the properties of the substance.

**Pesticide Resistance** – The ability of an organism to tolerate a pesticide. There are different levels of resistance. For example, some insects may be sensitive, weakly resistant or strongly resistant to a specific insecticide. Total resistance is immunity.

**Seal** – To enclose an area so that fumigant gas cannot escape too quickly. A good seal will contain a lethal amount of gas long enough to kill the target pests.

**Soil Texture** – The relative proportion of the different sizes of mineral particles – sand, silt and clay – that make up a soil.

**Solubility** – How readily a substance will dissolve in a liquid.

**Sorption** – Adsorption and/or absorption.

**Stratification** – When fumigants rise or fall, making layers of gas within a confined area. Diffusion is incomplete, leaving some areas untouched by the fumigant. Stratification results in an incomplete treatment.

**Tilth** – The physical condition of soil that determines the ease at which it can be tilled or cultivated and its suitability for seed germination and plant growth.

**Vapor Pressure** – The pressure exerted by a liquid or a solid as it volatilizes (becomes a gas).

**Vaporize** – When a solid or liquid turns into a vapor (gas).

**Volatility** – How readily a substance transforms from a solid or liquid into a gas.

Unit 1 defined a fumigant as a pesticide in gas form. At a high enough concentration, this gas can kill bacteria, fungi, insects, nematodes and weeds. Unit 1 also explained that as a gas, fumigant molecules can move into tiny gaps, such as between kernels of grain, or through small openings in the soil. This is why fumigants are so effective in certain situations.

This unit will focus on factors that affect fumigant performance: both characteristics of the fumigant and external factors.

## Characteristics of Fumigants

There are many fumigants on the market. Your job is to select the best product for the pest and situation at hand.

Boiling point, molecular weight, specific gravity, solubility and flammability are different for all fumigants. Each characteristic makes a fumigant act a certain way under certain conditions. Understanding how these factors affect application will help you select the best product for the job.

Always consult the label information for each product that you consider. It will contain information on the following characteristics.

## Molecular Weight and Specific Gravity

All substances, including air and fumigants, have a “molecular weight.” The molecular weight of air is about 29. Fumigants with a molecular weight lower than 29 are lighter than air and may rise. Those with a molecular weight higher than 29 are heavier than air and may sink.

All substances also have a “specific gravity.” The specific gravity of air is 1. Fumigants with a specific gravity greater than 1 are heavier than air and may sink. Fumigants with a specific gravity less than 1 are lighter than air and may rise.

Gases are unique in that their specific gravities are related to their molecular weights. For example:

$$\text{Specific Gravity of a Fumigant} = \frac{\text{Molecular Weight of a Fumigant}}{\text{Molecular Weight of Air}}$$

*NOTE: This relationship is valid only when the temperature and pressure of the fumigant and air are the same.*

The molecular weight and specific gravity of a fumigant can help you determine how well it will distribute throughout an area. Even distribution is referred to as an “equilibrium.” Most fumigant gases are heavier than air. For example, the molecular weight of methyl bromide is 94.95, making its specific gravity 3.28. This means methyl bromide is 3.28 times heavier than air. When the molecular weight of a fumigant is greater than or less than air, you may need to use fans and/or other tactics to achieve equilibrium during fumigation.

## Boiling Point

Boiling point is the temperature at which a fumigant becomes a gas. Most fumigants reach their boiling point between -125.9°F and 233.6°F. “Low-boiling” fumigants become gases below room or moderate outdoor temperatures (68° to 77°). To stabilize these chemicals, manufacturers keep them as liquefied gases under pressure in cylinders or cans. Fumigants with boiling points higher than 68°F, “high-boiling” fumigants, are initially liquids at normal fumigation temperatures. While these chemicals have slow evaporation rates, they will

eventually vaporize during treatment. To use these products, you may need to wait for a warm day or increase the temperature within the area you plant to treat.

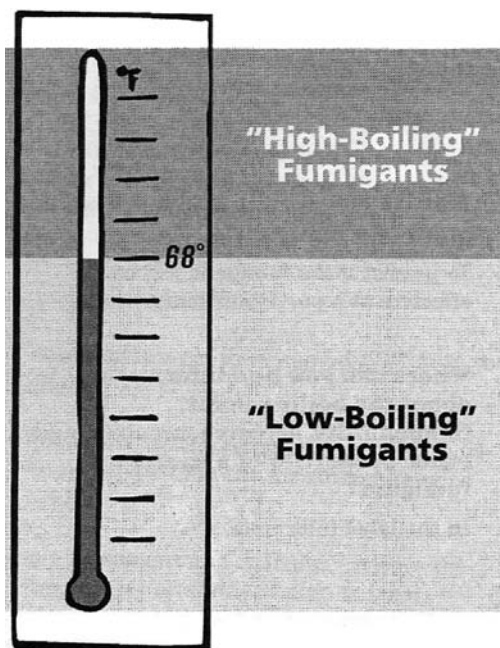

Boiling point also indicates the vapor pressure of a fumigant. In general, the higher the boiling point, the lower the vapor pressure, and the slower a fumigant will change to a gas.

## Solubility

Solubility tells you how readily a fumigant gas will dissolve in certain materials, depending on their moisture content.

Some fumigants are soluble in water, oil or other liquids. These pesticides may dissolve in commodities that have high moisture or oil contents. For example, methyl bromide is soluble in oil. If you use this fumigant to treat commodities with a high oil content, such as peanuts or soybeans, it may dissolve in the oil. Once dissolved, the methyl bromide may be difficult to aerate. This is particularly a problem when multiple treatments of these commodities are necessary.

## Flammability

Some fumigants, such as phosphine, are extremely flammable. Formulations of flammable fumigants may contain fire retardants. For example, some products that produce phosphine also produce ammonia and carbon dioxide. However the best way to prevent fire hazards is to apply and dispose of fumigants properly. Always read the label information to learn which conditions favor fire or explosions. The label information will describe how to avoid these problems.

**Table 3-1. Physical and chemical properties of fumigants commonly in use at the time this manual was printed.**

Fumigant	Molecular Weight	Boiling Point (°F)	Specific Gravity*	Flammability (in air)
1,3 dichloropropene	110.98	220.0	1.21	flammable
Carbon dioxide	44.01	-109.3	1.52	nonflammable
Chloropicrin	164.39	233.6	5.67	nonflammable
Dazomet	162.30	219.2	5.60	nonflammable
Metam sodium	129.18	221.0	1.21	nonflammable
Methyl bromide	94.95	38.4	3.28	nonflammable
Phosphine	34.00	-125.9	1.17	flammable
Sulfuryl fluoride	102.07	67.0	3.52	nonflammable

\* Specific gravity = the molecular weight of a fumigant divided by the molecular weight of air (29).

\*\* Carbon dioxide passes directly from the solid to the vapor state at this point.

# Test Your Knowledge

**Q. How can the molecular weight of a fumigant affect its ability to diffuse throughout a room?**

A. Fumigants with molecular weights lower than 29 are lighter than air and may rise. Those with molecular weights higher than 29 are heavier than air and may sink. Both extremes may require you to use fans and other means to prevent stratification.

**Q. Define stratification.**

A. When air and fumigant form layers and do not mix.

**Q. What does the solubility of a fumigant tell you?**

A. Solubility tells you how readily a fumigant will dissolve in water, oil or other substances. For example, if you apply a fumigant that is soluble in oil to grain that has a high oil content, the fumigant will dissolve into the oil of the grain. The fumigant will remain in the oil and contaminate the grain.

**Q. Why do you need to know the boiling point of a fumigant?**

A. To predict if the fumigant will be effective at a particular temperature.

**Q. Where can you find information about the boiling point, flammability, sorptive capacity and other properties of a specific fumigant?**

A. In the label information.

# Factors That Affect Fumigation of Raw Agricultural Products

A variety of factors affect the use and success of fumigants. Some of the most important factors in stored product fumigation are:

- Pest characteristics
- Temperature of the commodity or area you plant to treat
- Moisture in the commodity or area to be fumigated and in the air surrounding/within it
- Air movement and diffusion within the area you fumigate
- Construction of the structure within which you treat an item or the quality of the seal enclosing the area to be fumigated
- Applicator knowledge and skill

## Pest Characteristics – Raw Product Fumigation

Several aspects of the pest's biology can influence the effectiveness and timing of a fumigant treatment. These include:

- The insect's stage of growth. Pupa and eggs are the hardest to kill because they are not active. Adults and young larvae are most susceptible.
- The activity level of the insect. Active adults and larvae are easier to kill than are inactive or hibernating adults and larvae. This is because active insects have a higher metabolism, allowing them to process the pesticide faster. Therefore, whenever possible, wait until the insects are mature and active before fumigating.
- The feeding habits of the insect. Insects that develop outside grain kernels are usually more susceptible to fumigants than species that develop inside grain kernels.
- The size of the infestation. Heavy infestations are more difficult to control. Masses of insects generate large amounts of dust, damaged grain, webbing and cast skins. These materials interfere with fumigant penetration and increase sorption.
- Some insects have "resistance" to fumigants. Resistance is the ability of an organism to

tolerate a pesticide. There are various levels of resistance. For example, some insects may be sensitive, weakly resistant or strongly resistant to a specific insecticide. Total resistance is immunity. Frequent fumigation at dosages too low to kill all insects promotes problems with resistance.

Although this information is true for most insects, application recommendations vary with the pest. Use the information from Unit 2 to help you identify the most susceptible stage(s) of development and activity level(s) of the pest that you wish to control.

## Temperature

"Temperature" refers to the temperature

- Of the commodity that you plant to treat
- Under the tarp or within the structure where treatment will occur

Temperature affects both the dosage and exposure period needed for pest control. As a rule, the higher the temperature, the less fumigant you will need. This is because as temperature increases, insect metabolism increases. As metabolism increases, insects breathe faster, absorbing more fumigant. Less fumigant is needed to kill the pest. As the temperature drops, the reverse is true. Insect breathing slows. You may need to add fumigant to get the same level of control. Below 40°F, fumigants may not be effective at all.

Higher temperature also increases the volatility of fumigants. Volatility refers to how readily a substance turns into a gas (vaporizes). The higher the volatility, the faster a fumigant disperses and penetrates. Sorption by the material being treated decreases and less fumigant is needed. (See "Sorption" later in this unit to learn how temperature affects this process.)

Finally, temperature can cause a fumigant to "stratify." Stratification occurs when air and fumigant form layers and do not mix. In general, if the temperature of a fumigant is significantly lower than air, stratification becomes more severe.

For best results, fumigate when temperatures are above 60°F.

## Moisture

As the moisture content of a commodity increases, sorption increases. This makes it more difficult for a fumigant to penetrate a commodity. Therefore, products with high moisture contents



require higher doses of fumigant. High moisture contents also increase the potential that residues will exceed legal limits due to the increased sorption and slow desorption.

On the other hand, some dry fumigant formulations (such as phosphine tablets and pellets) need humidity to generate gas. These are called “moisture-activated” fumigants. If the air is too dry or the moisture content of the commodity is too low, these fumigants will stay in solid form.

## Air Movement

To be effective, a fumigant gas must diffuse (spread) evenly and quickly throughout the commodity or space that you are treating. The gas must enter small crevices, cracks or spaces so that a lethal concentration contacts every pest. Even distribution is called an “equilibrium.” The ability of a fumigant to reach equilibrium depends on several things. In general, gases diffuse more quickly at higher temperatures and lower air pressures. Fumigants also spread faster when their initial concentration is high and the penetration distance is short.

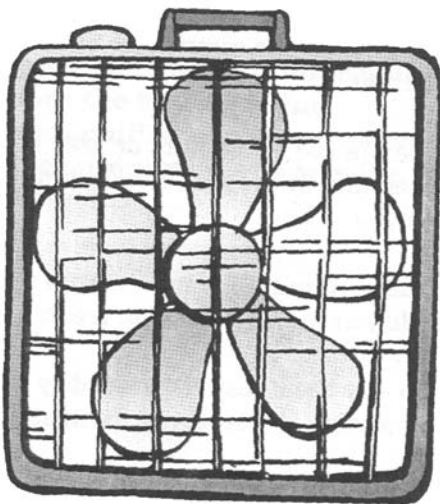

**Sometimes you will need help to distribute a fumigant throughout a treatment area.**

Some fumigants require air circulation to diffuse quickly. Without air circulation, the air and fumigant may form layers and fail to mix – a condition called “stratification.” Fans, ducts and blowers are often necessary. Select equipment that fits the job. Fans are usually sufficient to stir the air in open areas. Confined areas with tightly packed commodities may require blowers or ducts to move the fumigant from one place to another. However, once the fumigant reaches equilibrium, the problem of stratification decreases.

## Sorption

When a fumigant gas contacts materials, gas molecules undergo the process of “sorption.” There are two types of sorption: adsorption and absorption. Adsorption occurs when fumigant molecules stick to the surface of a treated material. Absorption occurs when the molecules penetrate into the material. Both types of sorption reduce the effectiveness of fumigants by removing molecules from the air. These bits of fumigant are no longer able to move freely and kill the target pest(s). Sorption also slows “aeration”: the process by which fumigant is released after treatment.

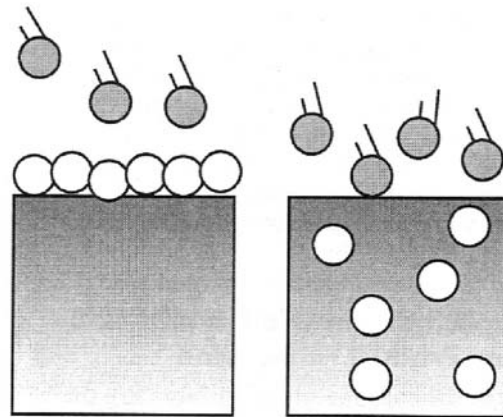

**Adsorption vs. absorption**

Some fumigants are more subject to sorption than others are. Read the label information for sorption information about each product you consider.

Commodities and the structures that house them also vary in their “sorptive” capacity. Loads of grain with many small pieces have a lot of surface area and are more sorptive. Inert surfaces such as metal are less sorptive.

Knowing how sorptive certain chemicals and commodities are is critical. This information will help you determine how much fumigant to use, how long to contain the fumigant and how long to aerate the treatment area or product. When sorption levels are high, you will need to use more fumigant. You will also need to increase the treatment time because diffusion is slower. When treatment is complete, aeration periods must be long enough to allow the fumigant to slowly “desorb” from the commodity. If aeration is too short, traces of fumigant may remain sorbed to the product. This can cause toxic residues, off-flavors or odors in the treated material.

As a rule, sorption is greater at cold temperatures. For example, if the temperature inside a warehouse is cool during fumigation,

the commodity(ies) will absorb or adsorb the fumigant at a higher rate. You will need to use more fumigant. The same is true for aeration. Aeration normally takes longer when temperatures are low or when products are cold.

Adsorption is usually greater with fumigants of high molecular weights and low vapor pressures.

## Construction of the Structure

Fumigant label information lists a range of dosages from which to choose. Each dosage fits a specific situation. The most important factor in selecting a dosage is the tightness of the structure. The ability of a building to hold a fumigant directly affects the amount of gas needed to sustain a lethal concentration throughout. Higher dosages are needed for structures that are of “loose” construction. For example, warehouses tend to have gaps around windows, doors and wall joints. Lower doses may be adequate for “tightly” constructed structures such as boxcars and fumigation chambers.

For loosely built structures, it is often better to “seal” the area than to increase the amount of fumigant you use.

## Seal

A tight seal around a structure or commodity ensures effective fumigation and the safety of those nearby. You can seal a structure or commodity in one of three ways:

- 1) Tape and seal all potential openings within a structure with plastic and fumigation tape.
- 2) Place a gas-tight tarp over the item or structure.
- 3) Use a fumigation chamber.

The quality of a seal is important. It can affect:

- The amount of fumigant needed (the tighter the seal, the less gas that will escape, and the less fumigant that will be needed)
- The length of time necessary to kill the target pest (the tighter the seal, the more constant the fumigant concentration, and the less time needed to achieve control)

A fumigation chamber is an example of a tight seal. Little gas escapes from a well-constructed chamber. On the other hand, placing

a gas-tight tarp over commodities or structures can provide a poor-to-excellent seal depending on:

- The condition of the tarp
- The tightness of the seams
- The type of ground seal

Structures in sandy soils or with dirt crawl spaces may lose gas through the soil. Commodities sitting on concrete floors may lose gas through the concrete. To prevent these problems, always tarp the top and bottom of structures and items on porous bases.

Some structures may be too large to tarp, such as warehouses or large grain bins. In these situations, a tape-and-seal job may be required. Always seal doors, windows and vents. This will prevent heavy loss through large gaps. In grain bins, you should also seal unloading augers, roof exhaust vents and eave gaps (openings where the roof meets the sidewalks). Although tape-and-seal fumigation can prevent many leaks, the fumigant can penetrate untarped walls, even when the walls are made solid materials like brick and concrete. You will usually need more fumigant to replace what is lost through untarped walls.

Also, consider the condition of the structure and the type of construction. A wooden structure, even when sealed, will not retain fumigants as well as one of brick, concrete or steel. This is because wood is more porous than the other materials. For example, round steel bins retain fumigant better than flat grain-storage bins, which are usually made of wood. In addition, wooden structures are often not built as “tightly” as structures made with other materials. For these reasons, it is often necessary to tarp wooden structures during fumigation.

## Applicator Knowledge and Skill – Raw Product Fumigation

In the end, you, the applicator, are the most important variable in raw product fumigation. Your education and training will directly affect the success and safety of your operation. Know and understand the properties of every product you plan to use. Consider how different factors will affect treatment. Understand the site – its limitations and its strengths. Choose your dosage and application methods accordingly.

## Test Your Knowledge

**Q. List several factors that influence a fumigant's effectiveness.**

- A.
1. Diffusion: how well a fumigant penetrates a commodity or how well it is circulated throughout an area.
  2. The sorptive capacity of the commodity to be fumigated.
  3. The temperature of the commodity or space to be fumigated.
  4. The moisture content of the commodity or area to be fumigated and the air surrounding/within it.
  5. The construction of the structure to be fumigated or the structure within which you will treat an item.
  6. The quality of the seal enclosing the area to be fumigated.
  7. The characteristics of the target pest.
  8. The level of resistance a pest may or may not have.

**Q. As a rule, at what temperature is fumigation most effective?**

- A. Above 60°F.

**Q. Define volatility. How does the volatility of a fumigant affect dosage?**

- A. Volatility refers to how readily a substance turns into a gas (vaporizes). The higher the volatility, the faster fumigant disperses and penetrates. Sorption by the material being treated decreases and less fumigant is needed.

**Q. What aspects of the pest and pest damage can affect fumigation? How does each aspect affect fumigant performance?**

- A.
1. The insect's stage of growth. Pupa and eggs are the hardest to kill because they are not active. Adults and young larvae are most susceptible.
  2. The activity level of the insect. Active adults and larvae are easier to kill than are inactive or hibernating adults and larvae. This is because active insects have a higher metabolism, allowing them to process the pesticide faster.
  3. The feeding habits of the insect. Insects that develop outside grain kernels are usually more susceptible to fumigants than species that develop inside grain kernels.
  4. The size of the infestation. Heavy infestations are more difficult to control. Masses of insects generate large amounts of dust, damaged grain, webbing and cast skins. These materials interfere with fumigant penetration and increase sorption.

**Q. What is the difference between adsorption and absorption? How do they affect the performance of a fumigant?**

- A. Adsorption occurs when fumigant molecules stick to the surface of the treated material. Absorption occurs when the molecules penetrate into the material. Both types of sorption reduce the effectiveness of fumigants by removing molecules from the air. These bits of fumigants are no longer able to move freely and kill the target pest(s). Sorption also slows "aeration" – the process by which the fumigant is released after treatment.

# Factors That Affect Soil Fumigation

The success of soil fumigation depends on how long a target pest is exposed to a lethal concentration of the fumigant. The distribution of fumigant between the air and moisture in soil is critical to this process. When you inject a fumigant into soil, it diffuses toward the soil surface through air spaces that exist between soil particles. The ability of fumigants to spread increases with the air content of soil. However, as it moves, the fumigant dissolves into the film of water that surrounds the soil particles. It is in this water that soil pathogens and nematodes live. Consequently, soil fumigants actually do most of their work within the films of water that surround the soil particles. When the fumigant reaches the soil surface, it escapes into the air and is degraded by ultraviolet light. Any fumigant left in the soil breaks down into nontoxic substances.

Many factors influence and distribution of fumigant between the air and water within treated soil. Some of the most important factors in effective soil fumigation are:

- Pest characteristics
- Soil temperatures
- Soil moisture
- Soil texture
- Soil tilth
- Soil organic matter content
- Applicator knowledge and skill

## Pest Characteristics – Soil Fumigation

Fumigants control soil pests in different ways. Soil insects are controlled primarily by exposure to toxic levels of fumigant in the air spaces between soil particles. Pathogens, nematodes and weeds, on the other hand, are killed by absorbing fumigant that is dissolved in the water that surrounds soil particles.

As with fumigation of stored products, several aspects of a pest's (insects, nematodes, pathogens and weeds) biology can influence the success of soil fumigation.

They include:

- The insect's stage of growth. Pupa and eggs are the hardest to kill because they are not active. Adults and young larvae are most susceptible.

- The activity level of the insect. Active adults and larvae are easier to kill than are inactive or hibernating adults and larvae. This is because active insects have a higher metabolism, allowing them to process the pesticide faster. Therefore, whenever possible, wait until the insects are mature and active before fumigating.
- The location of the pest within the soil. Soil pests in more exposed areas (i.e., areas closer to the site where fumigant is injected) are more vulnerable to soil fumigants.
- The sorptive capacity of a pest. The greater the sorption of a fumigant to a pathogen, nematode or weed, the better the control.
- Special features of the pest. For example, fumigants may not control hard-seeded weeds because their seeds have a waterproof coat that limits the uptake of fumigants. In addition, you need higher rates of soil fumigants to control cyst-type nematodes. In soil, most of these nematodes are present as eggs within cysts (the carcasses of dead adult females), which protect the nematode eggs from fumigants.

## Soil Temperature

Soil temperatures that are too high or too low can also affect fumigant performance. High soil temperatures reduce the solubility of fumigants in soil water. This can increase the speed at which fumigants diffuse through soil. If fumigants move too fast, concentrations may never reach high enough levels to be toxic. At soil temperatures above 75°F, excessive fumigants may be lost from the soil surface. On the other hand, cool soil temperatures, near 40°F, may prevent some fumigants from volatilizing. Temperatures between 50°F and 75°F at depths of 6 to 8 inches are ideal for soil fumigation.

## Soil Moisture

Soils that are too wet or too dry change the distribution of the fumigant. This can reduce the effectiveness of a treatment.

When soils are too dry, little fumigant can dissolve into soil water. Fumigant spread is rapid because fumigants diffuse through soil air spaces 10,000 to 30,000 times faster than they do through soil water. If you do not thoroughly seal the soil surface, the rapid spread of a fumigant allows it to escape from the soil too soon. This leaves little fumigant to dissolve into the

soil water. Low levels of fumigant in soil water mean that few target pests are actually exposed to the fumigant. Those that are may not contact enough fumigant for the treatment to be effective. Concentrations of fumigant may never get high enough to kill the target pests, or the concentrations may not remain high long enough to do the job.

When soils are too wet, fumigant dissolves into soil water too soon. This prevents it from spreading throughout the soil to be treated, thereby reducing the actual volume of soil the fumigant can contact. Consequently, some areas of the soil may contain too much fumigant, while others may not receive any. In addition, soil fumigants remain in soil water longer than they do in soil air spaces. “Fumigant injury” (damage to plants and crops caused by soil fumigants) can occur when fumigants persist beyond the normal waiting period in soils that have high moisture levels when you treat them.

Ideally, soils should be about half of “field capacity” when fumigated. Field capacity is the level of soil moisture at which soil water has moved out of the soil macropores and been replaced by air. To test the moisture content of soil, collect a small sample. Squeeze it in the palm of your hand. Soil with the right moisture content should barely retain its shape. If the soil is too wet, wait for it to dry before fumigating. If it is too dry, irrigate or wait for rain.

## Soil Texture

Soil texture affects fumigant performance by determining the size of the pore spaces within the soil. For example, sand and sandy loam soils are coarse. Coarse soils consist mostly of large mineral particles separated by large spaces. These spaces tend to be continuous, allowing fumigants to diffuse quickly and far from the point of injection. Clays and silt loams are fine-textured soils. They consist of a much larger percentage of small particles, which only allow spaces between them that are small and choppy. This restricts the flow of fumigants. Soil fumigants travel faster and more evenly in sand and sandy loam soils than in silt loams and clay soils. Fumigants also escape more readily from sandy soils.

## Soil Tilth

Tilth refers to the physical condition of soil relative to plant growth. It mainly concerns the size or volume of the pore spaces within the soil and the amount of water vs. air within those

spaces. Soil tilth is considered “good” when it promotes seed germination and plant growth. Agricultural practices such as plowing, cultivation and crop rotation significantly influence tilth.

Before fumigating soil, be sure it has good tilth. Soils with good tilth have relatively large, continuous spaces between soil particles with air and moisture levels that promote the rapid and even distribution of fumigants. If tilth is poor (such as from soil compaction), the size and continuity of airspaces decrease. This reduces the space available for fumigants to diffuse through soil.

In addition, be sure to break up dirt clods. Fumigants cannot penetrate dirt clods because they are small areas of highly compacted soil. It is also difficult to seal the soil surface when many clods are present.

## Organic Matter Content

Organic matter consists of plant and animal materials at various stages of decomposition. Soils with high levels of organic matter need higher rates of soil fumigants. This is because fresh or decaying plant material absorbs fumigants, reducing the total amount of product that remains to control soil pests. These effects increase when soil temperatures are too high or too low or when soils are too wet or too dry. Excess organic matter can also clog fumigation injection equipment and puncture plastic film used to seal the surface of fumigated soil. Be sure to plow under undecomposed plant debris at least several weeks before fumigation. This will promote decay that is more complete.

## Applicator Knowledge and Skill – Soil Fumigation

As the applicator, the treatment decisions that can influence the effectiveness of soil fumigation include the following factors.

### Time of Application

Time soil fumigation when environmental factors are best for fumigation. Pay particular attention to soil moisture and temperature. Although most soil fumigation is performed in the spring, soil temperatures, moisture and tilth are usually most favorable in the fall. Fall fumigation also frees up time in the spring, one of the busiest seasons for farmers. If you do

fumigate in the fall, however, be sure that fumigated areas are not contaminated over the winter by untreated soil from adjacent areas.

## Soil Preparation

Cultivate soil to a depth of at least 12 to 14 inches before fumigating. This will improve soil tilth and the success of the treatment. Thoroughly pulverize and smooth the top 12 inches of soil before applying the chemical. Subsoiling (cultivating soil below the plow layer) can also increase the effectiveness of fumigation by helping the chemical penetrate into deeper layers of the soil profile.

## Depth of Application

How deep to apply a fumigant depends on several things:

- The type and amount of product you plan to apply
- The characteristics of the soil (compaction, topsoil depth) in the area(s) to be treated
- The crop to be planted
- The organisms you wish to control

Remember that the objective is to treat as much of the “root zone” as possible. You will need to inject most fumigants at least 6 to 8 inches below the surface of the soil (measured before it is treated) or incorporate them to that same depth. Deeper application is often better. In many cases, such as in row fumigation where cultivation equipment builds a bed during fumigation, the depth of injection should be 14 to 20 inches below the surface of the soil (measured after treatment).

Injecting the fumigant at the wrong depth can cause a variety of problems. Shallow injection (12 inches deep or less) may miss target pests located below the level of application. Shallow injection can also result in excessive loss of fumigant from the soil surface. Applications that are too deep may prevent the product from diffusing into the top inch or two of soil, where many target pests (particularly weed seeds) live. Overly deep injections can also enter the subsoil. If fumigants are injected below the plow layer, the subsoil can act as a “fumigant barrier” or “fumigant sponge.” This limits needed movement of the pesticide upward through the soil.

The ideal injection depth for most situations is 18 inches. This should eliminate loss of

fumigant to the atmosphere and increase the amount of soil that is effectively treated.

## Chisel Spacing

Apply liquid fumigants to soil through injectors call “shanks” or “chisels.” Space these injectors according to:

- The type and amount of product you plan to apply
- The crop to be planted
- The organisms you wish to control

Fumigants diffuse outward from injectors to produce cylinders of treated soil. When performing “row treatments,” use one or two injectors that release just enough fumigant to treat the volume of soil for a single row in a field, planting or orchard. The soil between rows remains untreated. For “broadcast treatments,” space the injectors so that the cylindrical volumes of soil treated by each injection will overlap. This results in relatively uniform pest control over an entire field. You can space injectors as little as 6 inches apart, but no more than 12 inches apart. The best spacing will depend on the fumigant you use and the rate you apply.

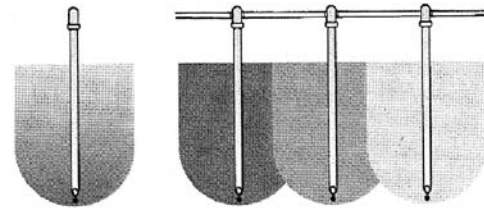

Fumigated soil volume and injector placement.

## Soil Sealing

It is important to establish a temporary soil seal during or immediately after soil fumigation. Sealing prevents fumigant from escaping prematurely from the top several inches of soil.

Without sealing, fumigants can also escape from chisel traces. Chisel traces are the depressions left in the soil by fumigant injectors. As the injectors travel across the soil, soil falls together behind them. The soil in these “traces” is often loose, leaving large airspaces between the soil particles. If soils are not sealed, a “chimney effect” may result where too much fumigant diffuses up through the chisel trace(s) toward the soil surface. Essentially, the fumigant follows the path of least resistance created by the larger air spaces.

There are several ways to seal soil. These include cultipacking, rolling, dragging, tarping and light irrigation. Cultipackers, rollers and drags seal the soil surface by moving more soil into chisel traces and by compacting the soil surface. You can also prevent fumigant from escaping by placing a polyethylene or plastic-coated nylon tarp over the treated soil. To seal soil with irrigation, water soils lightly and frequently – just enough to keep the top 2 to 5 inches of soil wet. Avoid flood irrigation. It can establish a water barrier near the soil surface that restricts diffusion of the fumigant into the top several inches of soil.

## **Exposure Period**

After treatment, leave fumigated soil undisturbed for several days to several weeks. The exposure period needed will depend on:

- The type and rate of fumigant
- The crop to be planted
- The target pest(s)
- Environmental conditions (particularly soil temperatures and moisture)

Waiting periods of two to three weeks are common but depend largely on soil temperatures and moisture. Soil fumigants require longer waiting periods under cold, wet conditions. Read the label to determine the proper exposure period for each product that you use. Planting or seeding a crop too soon after soil fumigation can result in severe, irreversible damage to the crop or plants you are trying to protect. Injury after soil fumigation tends to be less common for seeded crops than for transplanted crops.

## Test Your Knowledge

**Q. Describe how fumigants move through the soil.**

A. Once injected into soil, a fumigant diffuses toward the soil surface through air spaces that exist between soil particles. As the fumigant moves, it dissolves into the film of water that surrounds the soil particles. It is in this water that soil pathogens and nematodes live. When the fumigant reaches the soil surface, it escapes into the air and is degraded by ultraviolet light. Any fumigant left in the soil breaks down into nontoxic substances.

**Q. Name several characteristics of soil that can affect the performance of a soil fumigant.**

A. 1. Moisture  
2. Temperature  
3. Texture  
4. Organic matter content  
5. Tilth

**Q. Name several things controlled by the applicator that can affect the performance of a soil fumigant.**

A. 1. Timing of the application  
2. How deep the fumigant is injected  
3. How far apart the chisels are spaced  
4. How well the soil is sealed  
5. How well the soil has been prepared  
6. The length of exposure

**Q. Why is fall considered one of the best times of year to fumigate?**

A. In the fall, soil temperatures, moisture and tilth are more favorable for soil fumigation. Fall fumigation also frees up time in the spring, one of the busiest seasons for farmers. If you do fumigate in the fall, however, be sure that fumigated areas are not contaminated over the winter by untreated soil from adjacent areas.

**Q. What is soil tilth, and how does it affect fumigation?**

A. Tilth refers to the physical condition of soil relative to plant growth. It mainly concerns the size or volume of the pore spaces within the soil and the amount of water vs. air within those spaces. Before fumigating soil, be sure it has good tilth. Soils with good tilth have relatively large, continuous spaces between soil particles with air and moisture levels that promote the rapid and even distribution of fumigants. If tilth is poor (such as from soil compaction), the size and continuity of air spaces decrease. This

reduces the space available for fumigants to diffuse through soil. In addition, be sure to break up dirt clods. Fumigants cannot penetrate dirt clods, because they are small areas of highly compacted soil. It is also difficult to seal the soil surface when many clods are present.

**Q. How should you arrange fumigant injectors for a row treatment vs. a broadcast treatment?**

A. When performing row treatments, use one or two injectors that release just enough fumigant to treat the volume of soil for a single row in a field, planting or orchard. The soil between rows remains untreated. For broadcast treatments, space the injectors so that the cylindrical volumes of soil treated by each injection will overlap. This results in relatively uniform pest control over an entire field.

**Q. What problems can occur if you inject a fumigant at the wrong soil depth?**

A. Shallow injection (6 inches deep or less) may not reach all the target pests in soil and can result in excessive loss of fumigant from the soil surface. Applications that are too deep may prevent the product from diffusing into the top inch or two of soil, where many target pests live. Injection below the plow layer can trap the fumigant in the subsoil and prevent it from moving throughout the topsoil in the area to be treated.

**Q. What is the ideal injection depth for most soil fumigants?**

A. A minimum of 6 to 8 inches below the soil surface (measured prior to fumigation). In row fumigation, you should place the chemical 14 to 20 inches below the surface of the soil (measured after the treatment has been applied).

**Q. Name five ways you can seal the soil after fumigation.**

A. Cultipacking, rolling, dragging, tarping and light irrigation.

**Q. Name several factors that influence the length of an exposure period following soil fumigation.**

A. 1. The type and rate of fumigant used  
2. The crop to be planted  
3. The target pest  
4. Environmental conditions (particularly soil temperature and moisture)



# Unit 4. Pest Management Options

## Learning Objectives

After studying this unit, the learner will be able to:

- Define Integrated Pest Management (IPM).
- Describe the advantages and disadvantages of fumigants.
- Evaluate several non-fumigant pest management methods for soil and stored commodities.
- Use several methods simultaneously or sequentially to solve a pest problem.

This unit describes the principles of Integrated Pest Management (IPM). It explains how you can use fumigation as one aspect of a well-planned IPM program. You will learn several advantages and disadvantages of fumigants. You will also learn several ways to manage pest and disease problems without fumigation. These “alternatives to fumigation” may be cultural, biological or chemical. By using a combination of methods, you may often achieve the best control.

## Terms to Know

**Action Threshold** – A pest population level that triggers a management response. Sampling and regular observation are necessary to assess threshold levels.

**Aeration** – *Fumigant application:* The process of replacing fumigant-containing air or water with fresh air and/or water that contains little or no fumigant. Aeration must follow all fumigation operations.

**Aeration** – *Grain storage.* The process of passing air through a stored product such as grain to regulate temperature and moisture content.

**Auger** – A grain transfer tool used to load and unload grain and other stored products.

**Binning** – Placing grain or another raw product into a storage bin.

**Biological Control** – The use of natural enemies (predators, parasites or pathogens) to control pests and pest populations.

**Cultivar** – An agriculturally derived plant variety with unique characteristics. For

example, there are several cultivars of corn. Each one has a unique flavor, color or pest resistance.

**Cultivation** – Plowing and/or tilling to loosen the soil, remove weeds, etc.

**Cultural Control** – A pest control method that involves changing one or more crop production practices (sanitation, cultivation, crop rotation, use of resistant plant varieties, etc.) to create an uninviting or unfavorable environment for pests.

**Cuticle** – The protective outer covering of an insect.

**Fines** – Broken kernels and pieces of small foreign material within a load of grain.

**Harborage** – Shelter, a home or refuge for an organism.

**Headspace** – The open area between the stored product and the ceiling of the storage facility.

**Herbicide** – A pesticide used to kill or alter the growth and development of plants.

**Hot Spot** – An area in stored grain that is much warmer (10°F or more) than the surrounding grain. A hot spot indicates that the grain has a higher than normal moisture content, possibly caused by insect or fungus activity.

**Insecticide** – A pesticide used to control or repel insects or to reduce the unwanted or harmful effects of insects.

**Integrated Pest Management** – A pest management system that uses all appropriate strategies to reduce pest populations.

**Multipurpose Fumigant** – A fumigant that controls more than one type of pest.

**Pathogen** – An organism that causes diseases.

**Pest Resistant Plant** – A plant variety or cultivar that can reduce the reproduction of a pest on it, thereby reducing pest damage. Sometimes resistance is 100 percent effective. This means that a resistant variety is immune to a disease. Usually, the resistance is only partially effective.

**Pest Tolerant Plant** – A plant variety or cultivar that can produce a similar yield and

quality whether a particular pest is present or not. By using tolerant cultivars, farmers can produce normal yields from crops in pest-infested fields.

**Pesticide Resistance** – The ability of an organism to tolerate a specific pesticide. There are levels of resistance. For example, some insects may be sensitive, weakly resistant or strongly resistant to a specific insecticide. Total resistance is immunity.

**Plenum** – An enclosure in which air or other gases are at a pressure greater than the atmospheric pressure outside the enclosure.

**Raised Bed** – An elevated planting surface also called a “ridged row” that is prepared by plowing and grading soil using cultivation equipment. Raised beds are separated by shallow ditches that improve drainage.

**Rodenticide** – Any substance used to control or repel rodents or to reduce the unwanted or harmful effects of rodents.

**Skinning** – Superficial injury, such as to the surface of a grain kernel during harvesting, transport and storage.

**Topdressing** – A material such as a pesticide applied to or mixed into the upper surface of grain or soil.

## IPM and Decision-Making

There are many ways to control pests of raw agricultural products and soil. Your job is to select the best method for the situation at hand. Pesticides and other control methods often provide good to excellent control temporarily. However, for consistent, reliable, long-term control, you will need to use Integrated Pest Management (IPM).

IPM is an ecological approach to pest control. It is based on the habitat and life cycle of the pest. It combines all of the most appropriate pest control strategies into a unified, site-specific plan. IPM plans may include both nonchemical and chemical management methods. IPM is dedicated to managing causes rather than simply treating symptoms. IPM balances the level of control needed with any associated risks. The goal of an IPM program is to reduce pest numbers to an acceptable level in a way that is practical, cost-effective and safe for people and the environment.

## Prevention

The first strategy of an IPM program is prevention. Prevention of pests in stored products relies on sanitation, proper storage and monitoring the condition of the commodity before and during storage. Prevention of soil pests depends on sanitation, crop rotation, cultivation practices and the health of the crop(s). Prevention may help you exclude pests or provide them with unsuitable living conditions. Stopping a pest problem before it occurs saves time and money.

## Sampling and Observation

IPM also relies on sampling and regular observation. Sampling and observation will help you determine if treatment is needed and/or if previous control measures were effective. Check commodity storage areas regularly. When sampling and observing stored products, check their physical condition. Look for signs of new infestations. Determine what pests are present, how many of each kind are in the area and how much damage they are causing. When sampling and observing crop fields, look at the above- and below-ground parts of plants. Check for

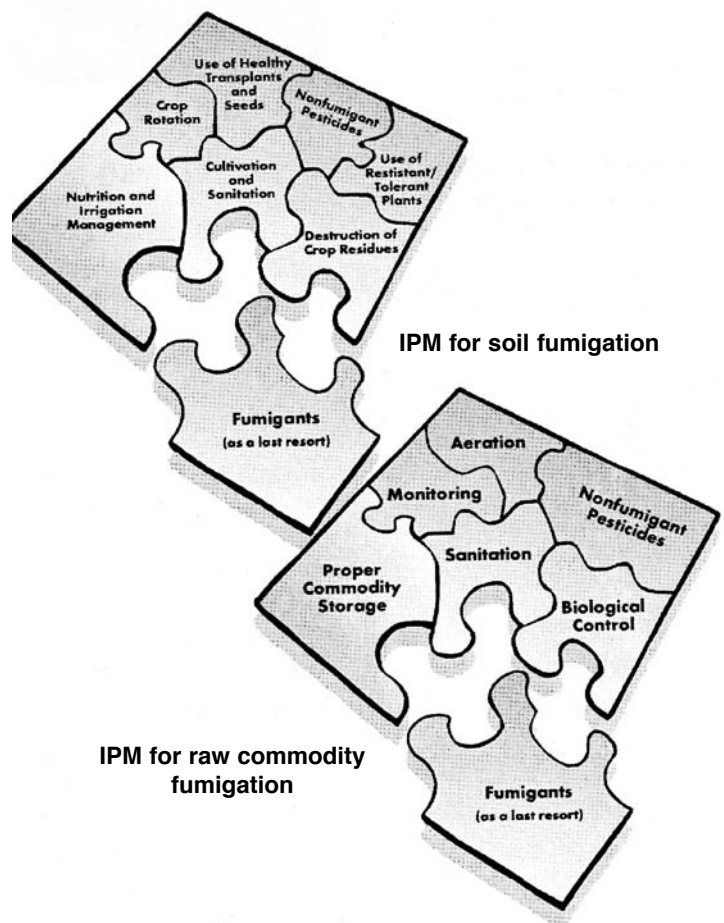

symptoms of disease or insect damage. Collect soil samples from fields to be planted. Submit them to a laboratory for a nematode assay – every year if possible.

## Thresholds

Use information from sampling and observation to make management decisions. Follow the action thresholds that indicate at what point pests need to be controlled.

Thresholds are the basis from IPM. “Damage thresholds” indicate how many pests must be present to cause a problem, such as economic damage or a safety threat. “Action thresholds” indicate the number of pests that must be present for a problem to be severe enough to warrant a control action. For example, the number of nematodes or nematode eggs in a soil sample is commonly used as an action threshold for soil fumigation. If the number in the sample exceeds the action threshold, the field needs treatment.

## Field/Product Histories

Knowing the history of a stored product or field is also useful when developing an IPM plan. For example, you can use the percentage of plants in a field killed by a particular soil-borne pathogen to determine when to apply a fumigant or other pesticide. If a soil-borne pathogen occurs at low levels one year, it can kill most of the plants in that field the next year if the field is not treated.

## When an Infestation Occurs

When an infestation does occur, identify the pest. Learn how it causes damage and when it is most vulnerable. Then, develop a control plan. Consider all appropriate control options. Your strategy should be economical and effective, while minimizing harm to people and the environment. Follow-up site inspections are critical. Did the control tactic work? Is re-treatment needed? Continue to monitor areas for long-term control.

Fumigation is only one option of an IPM program. Use it only as a last resort when nothing else works. For stored products, sanitation, proper grain storage and nonfumigant pesticides can often control pests without the help of fumigants. Control soil pathogens and pests with crop rotation, disease- or nematode-resistant varieties and nonfumigant pesticides.

Usually there is little you can do during the growing season to control soil pests. In some cases, you can apply nonfumigant pesticides when the crop is in the field. However, crop rotation, use of resistant plant varieties and fumigation must all be performed before the growing season starts. You cannot apply fumigants to fields that have already been planted because, in most cases, the process of injecting fumigant and the fumigant itself will injure the crop.

When deciding whether to fumigate stored products or soils, weigh these advantages and disadvantages.

## Advantages of Fumigants

- Depending on the specific situation and fumigant, fumigants are effective against insects, mites, diseases, nematodes, fungi, weeds and most other living things.
- Most fumigants are fast acting. They are the quickest way of controlling many pests.
- In some cases, they can provide total eradication.
- Human exposure is limited. Areas are evacuated during treatment and must be aerated before reentry.
- Most fumigants, when used properly, do not leave residues on surfaces.
- There are several ways to apply fumigants.
- They penetrate and treat spaces in soil and commodities like grain that cannot otherwise be reached.
- When treating raw products, you can apply them without disturbing the commodity.
- They usually are readily available.
- You can use some fumigants in or near food without leaving harmful residues, tastes or odors.

## Disadvantages of Fumigants

- They are highly toxic to most living things, including humans. Breathing even small amounts of some fumigants can be fatal.
- They may require special protective equipment, such as a self-contained breathing apparatus (SCBA) and gas detectors.

- They require highly trained applicators.
- They offer no residual control. Once an area, item or field is aerated, traces of fumigant do not remain to help control future pests.
- They must be confined in a tightly sealed area to be effective.
- Some may injure seeds and reduce germination. Others may leave toxic residues, tastes or odors if used incorrectly.
- Because they are fast acting, response to problems and emergencies must be quick. Spills, leaks and equipment failures usually call for immediate action.
- They usually require warm temperatures to be effective. Temperature requirements may be hard to meet, especially in the winter.
- Some are expensive.
- Some are corrosive.
- Some are flammable and explosive.
- Some fumigants are hard to remove from treated material.

Fumigants for raw products can be costly and dangerous. Always consider other pest control methods before fumigation. Fumigation should be your last resort. Use Integrated Pest Management (IPM) to select the best pest control method(s) for your situation. In this way, you may be able to reduce or avoid the need for fumigation.

## Pesticide Resistance

One of the biggest problems with pesticide use is “pesticide resistance.” Pesticide resistance develops when a group of pathogens or insects is able to tolerate doses of a specific pesticide that would kill a normal population of the same species. Surviving pests reproduce and pass their resistant traits to their offspring. Preventing resistance is of great importance for the pests of stored commodities. New laws and regulations have drastically reduced the number of insecticides approved for use against stored-product pests. As a pest control operator, you can protect the effectiveness of pesticides by:

- Using IPM
- Using alternative controls and nonchemical controls whenever possible
- Using pesticides only when necessary
- Avoiding repeated use of the same pesticide
- Doing a thorough job when applying a pesticide (do not leave behind pests that can develop resistance and reproduce)
- Fumigating only when nothing else works

## Alternatives to Fumigation

Many pests of raw commodities can be controlled without fumigants. The key is prevention. Prevention involves sanitation, proper grain storage and maintaining before and after it is placed into storage. In this way, you can keep pests away or reduce the number of pests that are able to develop. Other management strategies such as biological control, aeration, spot treatments, empty bin sprays, grain protectants, topdressing, pest strips and rodenticides help to reduce existing pest populations.

## Sanitation

The first step in preventing insect infestations is sanitation. By keeping bins and the areas around them clean, you can greatly reduce insect populations. Old grain and grain products provide food and habitat for insects. These residues can occur inside and around bins, in combines and in grain transfer equipment. Before storing fresh grain, clean the inside and outside of storage bins and buildings. Clean aeration ducts, augers and sidewalks. Use both a broom and vacuum. Dispose of all spilled or leftover grains and grain dust. Open the aeration ducts and augers to be sure they are clean. Clean bins immediately after they are emptied and again at least two to three weeks before adding grain. You should also clean bins before applying “empty bin sprays.” (See “Empty Bin Sprays” later in this unit). Always wear a dust mask when cleaning these and other storage areas. Mow regularly around bins to reduce harborage for rodents and insects.

## Proper Grain Storage

Harvesting grain does not end the danger of pests. You must also store it properly. Good grain storage can prevent infestation and the need for fumigation. In Arkansas, producers may store grain for a few weeks to a few years. The profitability of such storage depends on grain quality and marketing. Grain is usually

stored so that it can be sold when market prices are higher than they are during the harvest season.

## Grain Condition

The physical condition of grain when it is placed into storage influences its susceptibility to pests. Only high-quality, undamaged grain with a low moisture content can be stored successfully for long periods. Never mix new grain with old grain in storage.

## Drying Grain Before Storage

Grain is dried to prevent spoilage and to deter insect infestation. Most small grains are dried to 12 to 13 percent moisture. The moisture level may be 1 to 2 percent higher if the producer plans to hold the grain during the cooler part of the year only.

Drying methods may influence grain quality. High-speed, high-temperature drying produces more stress-cracked corn than low-temperature drying. Kernels with stress cracks break readily during handling. Broken kernels are more likely to spoil.

**Table 4-1. Maximum moisture contents for safe aerated grain storage in Arkansas.**

Grain Type and Storage Time	Maximum Moisture Content for Safe Storage (% wet basis)
<b>Shelled corn and sorghum</b>	
Sold as #2 grain by spring	14-15
Stored 6 to 12 months	13-14
Stored more than 1 year	12-13
<b>Wheat, oats, and barley</b>	
Stored up to 6 months	12-13
Stored 6 to 12 months	11-12
Stored more than 1 year	10-11

## Broken Kernels and Fines

Many insects that infest stored grain are not able to penetrate the seed coat of unbroken kernels. These pests depend on the presence of broken kernels and foreign material called "fines." Broken kernels are also more likely to spoil and mold than are unbroken kernels. Fines decrease the airflow from aeration fans. This can increase aeration time up to 50 percent. Fines

also tend to accumulate in the center of the bin. Fines hold moisture, further increasing the chance of insect and mold damage. This is especially true when fines are concentrated in certain parts of the storage.

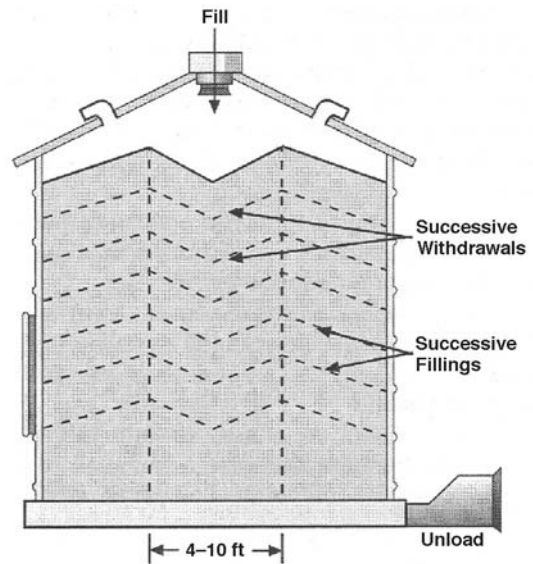

**Withdrawals during filling remove most fines from the core of fine material**

## Grain Cleaning

Cleaning grain before "binning" is the best way to minimize problems with fines. Rotary screen and aspiration cleaners work best. Rotary screen cleaners use a rotating screen to remove fines and foreign material from the grain as it is transferred to a dryer or storage bin. Avoid using perforated or screened sections in the auger. These usually do a poor job of cleaning the grain. They may even reduce grain quality by "skinning" or causing superficial damage to the kernels.

If you cannot clean the grain ahead of time, remove fines during bin loading. When grain is loaded into the center of a round bin, most of the fine material will collect in a center "core" under the spout. Eliminate this problem in one of two ways. First, try using a grain spreader. Grain spreaders distribute fines and grain evenly throughout the bin. This method retains the fines, which may have value as animal food. However, they tend to pack the grain, reducing airflow within the load. You can also remove the core of fine material periodically as the bin is filled. To do this, remove the grain from the bottom of the center core. Mix it with other grain and put it back in the bin.

## Peaked Grain

Peaks occur at the top of a grain pile just below the loading spout. There are several problems with leaving grain peaked in a bin. First, it is impossible to achieve uniform aeration. This is because air moves toward the nearest open areas, the sides, leaving the center core unaerated. (See "Aeration" later in this unit for more information on how it affects stored grain.) Second, when grain is loaded without a spreader, the fines tend to accumulate in the center under the spout. Fines are particularly prone to insect and fungal attack. They are also difficult to aerate. (See "Broken Kernels and Fines" earlier in this unit for more information on how they affect stored grain.) In addition, it is very difficult to enter a bin to sample the grain or to apply a topdressing if the grain is peaked and filled to the top of the bin. It is easier to walk on level grain than on sloped grain. There may also be insufficient headspace. Be sure to level the surface of stored grain so that it is not peaked.

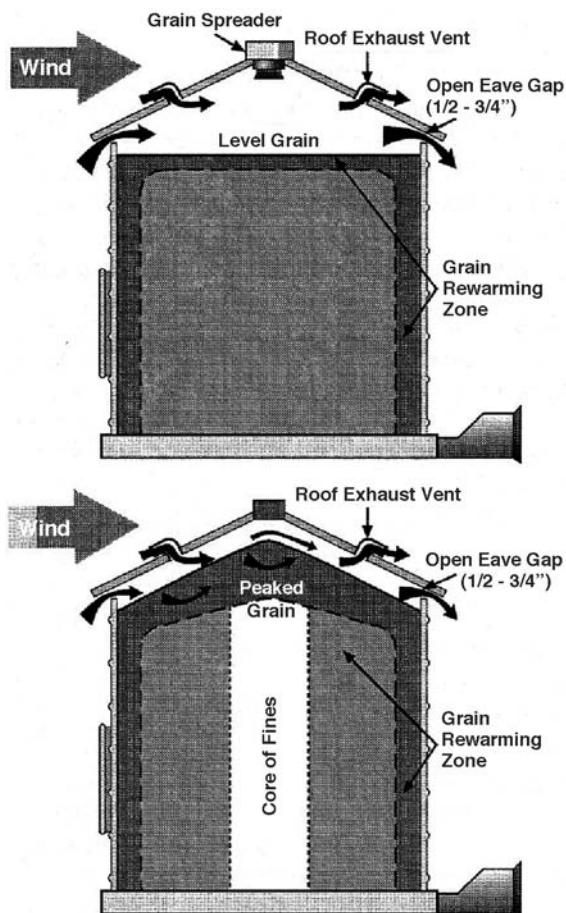

Peaked grain vs. level grain surface in storage bins.

## Storage Facilities and Packaging

Grain should always be stored in a steel bin. Be sure the bin is weather-tight, rodent-proof, and mounted on a moisture-proof concrete base. It should have a grain spreader, a perforated floor aeration system, an adequate fan and a weather- and rodent-proof roof vent. Caulk the seams of older bins and inspect them annually for moisture leaks. Buildings used to store other types of commodities should be dry and designed to exclude rodents, birds and flying insects. There should also be a minimum of harborage for pests. Move or eliminate unnecessary equipment, wood, rocks and other popular pest hideouts in and around storage facilities.

## Storage Time

Storage pest problems tend to be seasonal. Grains harvested and stored in the heat of the summer are more susceptible to pests than grains harvested in the fall when temperatures are cooler. As a rule, the longer a commodity is stored at 60°F to 90°F, the greater the chance of pest problems. If a producer needs to store a commodity for more than one year, or if conditions are more likely to be favorable to pests, he or she should increase monitoring and pest prevention efforts.

## Aeration

Proper aeration can control insects in many ways. Aeration is the movement of air through grain to regulate moisture and temperature. By preventing moisture from building up and moving through a commodity, aeration helps to limit mold growth. This, in turn, reduces the food supply for fungus-feeding insects. Aeration also controls "hot spots." Hot spots are sites that are much warmer (10°F or more) than the grain in the rest of the storage bin. These areas indicate that the grain has a higher than normal moisture content and may harbor insects or fungi.

Aeration procedures are the same for all types of stored grains. In the fall, aerate to lower the grain temperature below 60°F. At this temperature, most insect and mold activity will decrease. In the fall, winter and spring, aerate to control moisture migration and to create a uniform temperature throughout the grain

mass. If you plan to store grain through the summer, you may need to aerate to control moisture during this season as well. However, most grain is sold before summer to make room for the next crop.

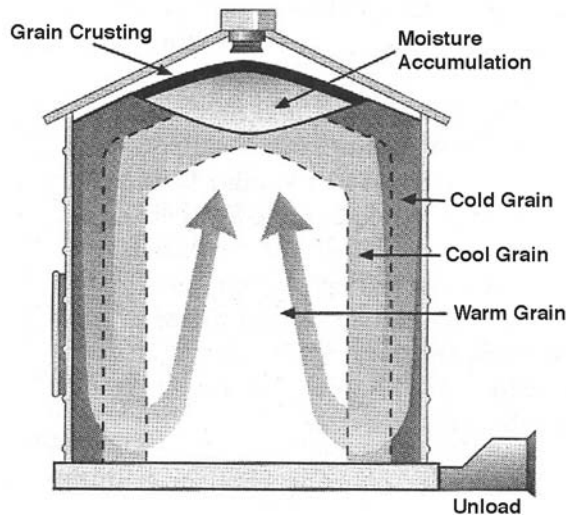

**Example of moisture migration in grain stored several months without aeration.**

## Biological Control

Biological control is the use of natural enemies (predators, parasites or pathogens) by humans to control pests and pest populations. These natural enemies, also called biocontrol agents, can sometimes reduce the number of pests in raw commodities. Predatory or parasitic insects are the most common biocontrol agents used to control insect pests of raw commodities.

Unfortunately, it may be difficult to effectively use biological control in an IPM program. This is because beneficial insects require some host insects to become established. It is difficult to keep these pest insects from reaching damaging levels. Stay informed about new developments in biocontrol that may help prevent infestation.

## Non-Fumigant Pesticides

### Empty Bin Sprays

Another management strategy is to coat empty bins with insecticidal sprays. These pesticides will kill eggs and insects missed during cleaning. Treat bins as soon as they are clean. Try to delay treatment until the weather is

warm and the insects are active. Insecticides are most effective at this time. If treatment occurs more than three months before the bin will be filled, repeat the application at least two weeks before storing the grain. Apply the spray to as many surfaces as possible. Be sure to hit all joints, seams, cracks, ledges and corners. Spray the ceiling, walls and floor to runoff. Spray beneath the bin and its supports. Treat the outside surfaces in a similar fashion. Then apply the insecticide in a six-foot border around the outside foundation. For increased protection, treat harvesting equipment, elevators, augers, trucks and wagons. Be sure these items are thoroughly cleaned. Insecticides will kill most insects emerging from cracks and crevices.

Unfortunately, empty bin sprays do not work for every type of storage bin. More and more producers are using metal bins with perforated floors. These floors aid in grain drying and aeration. They also permit broken grain and grain dust to gather in the subfloor plenum. This is an ideal area for insects to thrive. Additionally, subfloors are often difficult to remove. It may be difficult to inspect, clean or apply insecticides under them. In these cases, fumigation may be your only practical method of pest control.

## Grain Protectants

You can prevent or reduce insects by applying insecticides directly to the grain. These "grain protectants" are usually applied as grain is moved into storage. Grain protectants are intended to protect the grain, not to eradicate an existing infestation. For eradication, use a fumigant.

If a producer plans to hold grain for more than one month and the grain temperature is likely to be above 60°F, treat the grain with a protectant. To apply liquid protectants, use a gravity drip, compressed air or wipe-on applicator to apply the insecticide as the grain is augered or elevated into the bin. Mixing of the insecticide and the grain will occur during the bin-filling process. Use the auger diameter, angle and speed as well as the type of grain to determine the application rate.

Grain protectants are also formulated as dusts. You can apply dusts to grain in trucks before transfer. Spread the dust evenly over the surface of the grain and mix it in with a shovel. Complete mixing will occur as the grain is loaded into the bin.

Unfortunately, insecticides tend to break down faster in areas with high temperatures and moisture. If the moisture level of grain is greater than 13 percent and its temperature exceeds 90°F, a treatment may last for only a couple of weeks. When treating warm grain, be sure to aerate and cool it as soon as possible after it is introduced into the bin. Aeration will not remove the insecticide from the grain.

Most grain protectants are not registered for use on all types of grain. Be sure that you use the correct insecticide for the product you intend to treat. Consider all types of registered protectants including synthetic pesticides, naturally produced toxins, abrasives and growth regulators.

## Topdressing

Some areas of a grain bin, such as the headspace at the top, are likely to remain hot and humid. These conditions cause some grain protectants to break down quickly at the grain surface. The headspace is also the area where reinfestation tends to recur after fumigation. This is because chemical protectants break down more quickly, and the moisture content of the grain in this area makes it more favorable to insect pests. Treat the surface of the grain beneath the headspace with an insecticide registered as a topdress treatment. Both sprays and dusts work well. Mix half of the treatment with the upper 3 to 6 inches of grain. Be sure the grain is dry and less than 90°F. The bin should be insect-tight below the treated surface. Once the insecticide is in place, do not disturb the treated surface. It acts as a protective barrier over the entire load of grain. Topdressings can be especially useful against moths, such as the Indianmeal moth, that tend to stay near the grain surface.

*NOTE: Topdressings will kill insects on the surface and in the upper few inches of grain. They can also prevent new insects from entering the grain load from the top surface. However, they will not control existing infestations deeper in the bin.*

## Pest Strips

You can also hang resin strips in the headspace in the top of the bin to help control adult moths. Use one strip per 1,000 cubic feet of air space. Replace them once every three

months. For resin strips to be effective, you must temporarily seal the top of the bin, including the roof vent. Aeration will prevent this treatment from working.

## Rodenticides

Rodents harm stored grain by eating it and contaminating it with feces and saliva. There are many rodenticides registered for the control of rats, mice and other rodents. Before using rodenticides, fumigants or nonfumigants, to control vertebrate pests, develop an IPM program. Include prevention through structural exclusion and sanitation, sampling, and nonchemical controls such as snap traps. These methods may reduce or eliminate the need for rodenticides.

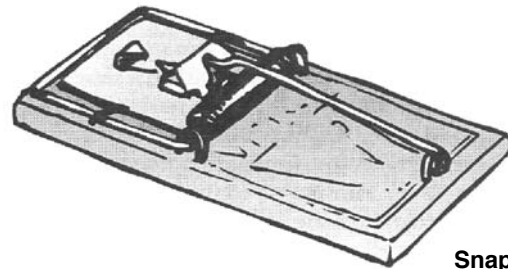

Snap trap

When pesticides are necessary, try nonfumigant rodenticides first. Choose between anticoagulants and nonanticoagulants. Anticoagulants cause death by internal bleeding. These chemicals are normally placed with baits in bait stations. Nonanticoagulants cause death by stopping the heart, damaging the intestines or liver or by attacking the central nervous system. These chemicals act quickly and rodents are usually less resistant to them. However, rodents are more likely to reject nonanticoagulants as food. You may need to prebait with untreated food to encourage consumption.

If control with nonfumigant rodenticides is poor, it is usually due to:

- Insufficient or low-quality bait
- Low numbers of bait stations
- Failure to treat the entire infested area
- Invasion from untreated areas such as outside a structure
- Poor placement of the stations



- Other foods being more readily available
- Pesticide resistance

When possible, pinpoint the problem and correct it before resorting to fumigation.

## Fumigation

Sanitation, proper grain storage, aeration and nonfumigant pesticides can go a long way toward preventing or reducing pests in stored grain and other raw products. For some situations, however, fumigation may be the only answer. Fumigants control pests by diffusing through the spaces between grain kernels as well

as into the kernels themselves. They often work better than nonfumigant pesticides because they can penetrate into places that are not accessible with insecticide sprays or dusts. They can also kill all stages in an insect's life cycle.

Before using a fumigant to control pests in stored grain and other raw products, make sure you need it. Monitor pest populations throughout the storage period. Do not hold grain or other raw products in storage for longer than necessary. Use all possible cultural and non-fumigant chemical controls to maintain pest populations below damaging levels. Before you decide to fumigate, make sure that pest populations are high enough to warrant fumigation.

## Test Your Knowledge

### Q. What is Integrated Pest Management (IPM)?

- A. IPM is an ecological approach to pest control. It is based on the habitat and life cycle of the pest. It combines all appropriate pest control strategies, including nonchemical and chemical management methods. IPM is dedicated to removing causes rather than simply treating symptoms. Prevention is key. IPM balances the level of control needed with any associated risks. The goal of an IPM program is to reduce pest numbers to an acceptable level in a way that is practical, cost-effective and safe for people and the environment.

### Q. How does fumigation fit into an IPM program?

- A. Fumigation is only one part of an IPM program. Because it is specialized, very toxic and often expensive, fumigation is usually the last resort to a pest problem.

### Q. Why is regular observation of stored grain and field crops important in effective pest management programs?

- A. Sampling and regular observation allows you to check for pests in an area to determine what pests are present, how many of each kind are in the area and how much damage they are causing. Sampling and observation will help you determine if treatment is needed and/or if previous control measures were effective.

### Q. List some of the advantages of fumigants.

- A.
1. They are effective against insects, mites, diseases, nematodes, fungi, weeds and most other living things.
  2. Most are fast acting.
  3. They are capable of providing total eradication.
  4. Human exposure is limited.
  5. Most fumigants, when used properly, do not leave residues on surfaces.
  6. There are several ways to apply fumigants.
  7. They penetrate and treat hard-to-reach areas.
  8. You can apply them without disturbing the commodity.

9. They are usually readily available.
10. You can use some fumigants in or near food without leaving harmful residues, tastes or odors.

### Q. List some problems with fumigants.

- A.
1. They are highly toxic to most living things.
  2. They require special protective equipment.
  3. They require highly trained applicators.
  4. They offer no residual control.
  5. They must be confined in a tightly sealed area to be effective.
  6. Some may injure seeds and reduce germination. Others may leave toxic residues, tastes or odors.
  7. Response to problems and emergencies must be quick.
  8. Temperature requirements may be hard to meet.
  9. Some are expensive.
  10. Some are corrosive.
  11. Some are flammable and explosive.
  12. Some fumigants are hard to remove from treated material.

### Q. How can you prevent pesticide resistance?

- A. As a pest control operator, you can protect the effectiveness of pesticides by:
- Using IPM
  - Using alternative controls and nonchemical controls whenever possible
  - Using pesticides only when necessary
  - Avoiding repeated use of the same pesticide
  - Doing a thorough job when applying a pesticide (do not leave behind pests that can build up resistance and reproduce)
  - Fumigating only when nothing else works.

### Q. How often should you clean grain storage bins to prevent insect infestations?

- A. Clean bins immediately after they are emptied and again at least two to three weeks before adding grain. Before storing fresh

grain, clean the inside and outside of storage bins and buildings. You should also clean bins before applying “empty bin sprays.”

**Q. Name several things you can do to reduce stored grain’s susceptibility to insects and disease.**

- A.
1. Clean and dry the grain before placing it into bins.
  2. Always store grain in a steel bin that is weather-tight, rodent-proof and mounted on a moisture-proof concrete base.
  3. Remove as much fine material as possible or spread out the fines throughout the load.
  4. Level the surface of the grain so that it is not peaked.
  5. When possible, store the grain in the fall when temperatures are cooler.

**Q. What technique can you use to maintain ideal moisture levels and temperatures within a load of stored grain?**

A. Aeration.

**Q. Why is it important to keep stored grain cool and dry when applying insecticides?**

A. Insecticides tend to break down faster in areas with high temperatures and moisture.

**Q. True or False: Topdressing will kill insects throughout a load of grain.**

A. False.

# Pathogens and Pests in Soil

## Alternatives to Fumigation

There are several methods and tools you can use to control pests and pathogens in soil besides fumigation. These include a variety of cultural controls methods and nonfumigant pesticides.

## Cultural Control Methods

Cultural control methods are some of the most effective nonchemical ways to control soil pests. Cultural practices include crop rotation, use of resistant plant varieties, destruction of crop residues, use of healthy transplants and seeds, cultivation practices, nutrition and irrigation management and sanitation. When properly used, these tactics reduce the need for or improve the effectiveness of fumigation and nonfumigant pesticides. Cultural practices are also often less expensive.

## Crop Rotation

Crop rotation is one of the most important cultural controls for managing soil-borne pathogens, nematodes, insects and weeds. Crop rotation works like this:

**Year 1** – A primary crop (tobacco, corn, etc.) is planted in a given field.

**Year 2** – A secondary crop (rye, fescue, etc.) that does not support soil-borne pests of the primary crop is planted in the same field. Without the primary crop to attack, soil-borne pest numbers will drop. Secondary crops are often called “non-host crops.”

**Year 3** – The primary crop is replanted. Because a secondary crop was planted in the field for one year, fewer pests will be present to damage the primary crop.

For example, tobacco is often rotated with wheat, rye or fescue. Many of the nematodes and pathogens that commonly attack tobacco (cyst and root-knot nematodes, and diseases such as black shank, bacterial wilt and black root rot) cannot reproduce or reproduce poorly on wheat, rye or fescue. Thus, during rotation, populations of these pests fall. When tobacco is replanted, pest problems are fewer.

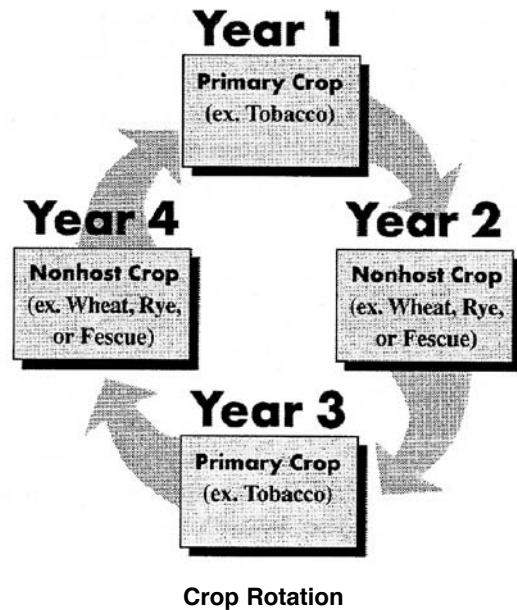

Longer rotations (when a secondary crop is planted for three or more years before a primary crop is replanted) are best. However, even a two-year rotation with a resistant or nonhost crop is better than planting the primary crop year after year in the same field.

## Resistant and Tolerant Plant Varieties

Many crops have varieties or cultivars that are “resistant” or “tolerant” to soil-borne pests. Resistant plant varieties reduce the ability of a pest to reproduce in or on that variety, thereby reducing the damage that the pest causes. Tolerant plant varieties, on the other hand, do not affect the reproduction of soil-borne pests. Instead, these plants are able to produce a similar yield and quality whether a particular pest is present or not. By using tolerant cultivars, farmers can produce normal yields from crops in pest-infested fields. Resistant and tolerant cultivars are often rotated with a nonhost crop. You can also combine resistant and tolerant plant varieties with other cultural practices, contact pesticides or fumigants to manage soil-borne pests.

## Destruction of Crop Residues

After harvest, fields usually contain a lot of leftover plant material. These residues act as food and habitat for soil-borne pests. Crop residues can sustain pests long after the crop is gone. Populations may even build up and carry over

into the next planting season. Destruction of crop residues after harvest eliminates this food source. Pest populations are unable to persist.

Destruction of crop residues is important for managing diseases on many crops, including tobacco. For example, the roots and other parts of tobacco plants are often still alive long after harvest. This living plant material provides food and shelter for soil-borne pathogens and nematodes. Insects can feed on leaves that remain on the plant or regrowth that forms from the stalks and roots. To discourage pest populations, it is important to kill the plants by turning the crop with a plow to expose the roots to the sun and wind. After the plants are dead, cut up debris into small pieces that will rot quickly. Incorporate these pieces into the soil. Plant a cover crop to reduce soil erosion.

Although cultivation is the most common way to eliminate crop residues, other methods are available as well. One option is to feed aboveground parts of some crops (like peanut vines) to livestock. Either allow the animals to graze the field after harvest or bale the vines for feeding elsewhere. In other situations, you can burn or compost crop residues.

## Healthy Transplants and Seeds

Using healthy transplants and seeds reduces the chance that a new soil pathogen will be introduced into a field. If a pathogen already exists in the field, many of the healthy plants and seeds have a good chance of avoiding infection. Even when the healthy plants or seeds become infected, the delay in onset of the disease (resulting from the amount of time it takes for the pathogen to find the host) often limits the amount of disease and ultimate damage. Many companies guarantee their seeds and transplants to be free of disease and pests. Be sure to purchase your seed and transplants from reputable vendors.

## Cultivation Practices

Certain cultivation practices can also reduce problems caused by soil-borne pests. These include:

- Planting into raised beds
- Deep plowing
- Increasing the amount of organic matter in soil



**Raised beds**

Planting into raised beds can enhance root growth, improve aeration and encourage soil drainage. These improved growing conditions help plants to develop more quickly. They may also slow the spread of pathogens that like wet soil conditions. Deep plowing works because some common soil-borne pathogens live primarily near the soil surface. Plowing buries these pathogens deeper in the soil profile, increasing the distance they must move to infect a new crop. Increasing organic matter can improve pest control by enabling the natural enemies of soil-borne pests to build up. Higher levels of organic matter improve the ability of these organisms to persist at levels high enough to reduce the populations of soil-borne pests.

## Nutrition and Irrigation Management

Healthy plants can often resist soil pathogens. Fertilize and add organic matter as recommended for the crop. Maintain a soil pH that is favorable to the crop. Irrigate when necessary. Proper irrigation can maintain a soil environment that is less favorable for some pathogens. Conditions that are too wet or too dry can stress the plants and allow pest populations to flourish.

## Sanitation

Whenever possible, clean farm implements before using them in a different field. Nematodes, insects and diseases live in the soil left on equipment. They can spread from

infested to healthy fields by “catching a ride” on vehicles and farm equipment.

## Nonfumigant Pesticides

Cultural practices can go a long way toward preventing or reducing soil-borne pests. However, sometimes you will need to use pesticides to prevent serious damage to crops. Fumigants are not always the best choice when it is necessary to use a pesticide. Nonfumigant pesticides usually control soil insects and some root and stem diseases better than fumigants. Nonfumigant pesticides also provide good to excellent control of nematodes and weeds in some cases. In addition, many nonfumigant fungicides, insecticides and herbicides can be used during the growing season, while fumigants cannot.

Nonfumigant pesticides are usually formulated as liquids or granules and applied directly to the soil or to the crop. In many cases, if you apply chemicals to the soil surface, you will need to incorporate them into the soil immediately after application.

## Fumigation

For some situations, fumigation may be the only answer. Some farmers have limited amounts of land. They may not have enough room to rotate crops. With no rotation, disease and nematodes can be difficult to manage

without pesticides. Pest-resistant crop varieties are not always effective or available. Biological and nonfumigant chemicals may not provide the same level of pest control as fumigants do for the specific pest(s) causing the problem. In fact, fumigants tend to provide better control of nematodes and soil-borne bacteria than do nonfumigant pesticides.

Before using a soil fumigant (or any pesticide), be sure you need it. If you suspect a nematode problem, take soil and/or root samples. Send them to a lab for analysis. Look for soil insects or evidence of their damage. Determine whether nematode or insect numbers are above the action threshold(s). Keep track of weed infestations and the number of plants in each field killed by a disease over time.

Some fumigants, called “multipurpose fumigants,” control more than one soil problem (for example, bacteria, nematodes, insects, and weeds). Others control only a single type of pest. Use a multipurpose fumigant when plant-parasitic nematodes are present in a field and you observe a high percentage of disease in the field during the previous season. For example, you may need to use a multipurpose fumigant in a tobacco field with root-knot or tobacco cyst nematodes if 5 percent of the plants died in previous years due to bacterial wilt.

Above all, be sure you are using soil fumigation as a last resort.

## Test Your Knowledge

**Q. Name several cultural control methods you can use to control pests and disease in soil.**

- A. Crop rotation, use of resistant plant varieties, destruction of crop residues, use of healthy transplants and seeds, cultivation practices, nutrition and irrigation management and sanitation.

**Q. Describe how crop rotation works.**

- A. 1. Year 1 – A primary crop (tobacco, corn, etc.) is planted in a given field.  
2. Year 2 – A secondary crop (rye, fescue, etc.) that does not support soil-borne pests of the primary crop is planted in the same field. Without the primary crop to attack, soil-borne pest numbers will drop.  
3. Year 3 – The primary crop is replanted. Because a secondary crop was planted in the field for one year, fewer pests will be present to damage the primary crop.

**Q. How do crop residues encourage pest and disease populations to flourish?**

- A. After harvest, bits of plant material left in a field act as food and habitat for soil-borne pests. Crop residues can sustain pests long after the crop is gone. Populations may even build up and carry over into the next planting season.

**Q. What kinds of cultivation practices can reduce soil-borne pests?**

- A. Planting into raised beds, deep plowing and increasing organic matter in soil.

**Q. Name three nonchemical ways you can enhance crop growth and help plants to resist soil pathogens.**

- A. 1. Utilize resistant and tolerant plant varieties.  
2. Destroy crop residue after harvest.  
3. Use healthy transplants and seed.  
4. Practice proper plant nutrition and irrigation management.

**Q. In general, what types of soil-borne pests are best controlled by fumigation?**

- A. Plant-parasitic nematodes and soil-borne bacteria and fungi.

**Q. When should you use a multipurpose fumigant?**

- A. When several soil-borne pests are present in a field at damaging levels. This situation is often indicated by a high percentage of disease in the field the previous season. Fumigation will help ensure proper control for subsequent seasons.

**Q. True or False. Fumigant pesticides are always the best choice for controlling soil-borne pests.**

- A. False. You can control many pests and pest problems by
- Rotating crops
  - Using resistant/tolerant plant varieties
  - Destroying crop residues
  - Using healthy transplants
  - Practicing good sanitation, cultivation practices and nutrition and irrigation management
  - Using nonfumigant pesticides

# Unit 5. Methods of Fumigation

## Learning Objectives

After studying this unit, the learner will be able to:

- Describe several methods of fumigation used to treat raw commodities and soil.
- Discuss the pros and cons associated with each method.
- Select the most appropriate fumigation method for a particular situation.
- Understand the importance of proper aeration.
- Aerate commodities and soil safely and effectively.
- Calibrate soil fumigation equipment.

This unit describes the most common methods used to fumigate structures, raw commodities and soil. Each method has advantages and disadvantages. You will learn what these are and how to use this information to select the best type of fumigation for a particular situation. This unit also discusses the importance of proper aeration. You will learn about factors that affect the speed and success of aeration. You will also discover how to perform these procedures yourself. Finally, this unit will discuss the importance of equipment calibration and some calibration techniques used for soil fumigation.

## Terms to Know

**Absorption** – When fumigant molecules penetrate into a material (commodity, soil or other item being fumigated).

**Adsorption** – When fumigant molecules stick to the surface of a material (commodity, soil or other item being fumigated).

**Air Wash** – A method of aeration used in vacuum fumigation. Air washing involves drawing a second vacuum after the exposure period is complete and then breaking this vacuum with fresh air.

**Billowing** – When air or gas causes something to bulge outward. In tarpaulin fumigation, this occurs when gusting winds cause a tarp to bulge away from the item or structure that it is covering.

**Blower** – A machine that generates and directs an air stream in a particular direction.

**Boxcar** – A large, roofed container with enclosed sides used to transport freight. Boxcars

usually have sliding doors on each side. Trains usually transport boxcars.

**Calibration** – The process of measuring and adjusting the amount of pesticides a piece of equipment applies.

**Chisel** – A strong, heavy, tractor-drawn tillage tool with curved points used to stir soil deeply without turning it.

**Cultivate** – To plow, till or loosen the soil.

**Desorption** – The liberation or removal of a fumigant from other substances.

**Diffusion** – The process of spreading out or distributing evenly in a space.

**Dosage** – The concentration of a fumigant (ounces, ppm, etc.) x the exposure time (hours, minutes, etc.). The dosage requirements depend on the pest, the fumigant, the temperature, the rate of leakage (some leakage is inevitable), and many other factors.

**Fumigation Tape** – Strips of adhesive material used to seal doorways, windows and other areas where gas might escape during fumigation. You can also use fumigation tape to join together two or more tarps during tarpaulin fumigation. Fumigation tape has a plastic or vinyl coating that reduces fumigant penetration.

**Gas Detector** – A device used to check the concentration of fumigant in the air.

**Gastight** – Something that does not allow gas to enter or pass through. Gasproof.

**Ground Seal** – The sealing of tarps to the ground to prevent fumigant loss during fumigation.

**Liquefied Gas** – A fumigant that must be kept under pressure in order to remain a liquid. These fumigants change from liquid to gas when released from their pressurized containers.

**Nonsparking Fan** – A machine that safely recirculates air in potentially explosive environments.

**Parts Per Million (PPM)** – The number of parts of a substance in one million parts of another substance. For example, if a gas detector reads “5 ppm,” it means that there are five parts of fumigant to every one million parts of air.

**Permeable** – Having pores or openings that permit liquids or gases to pass through.



**Plow Layer** – The band of soil that extends from the soil surface to the depth reached by cultivation – usually 5 to 8 inches below the soil surface.

**Prepac** – Aluminum phosphide fumigant tablets that are packed in a gas-permeable material.

**Pulverize** – To break something into small particles by crushing or beating it.

**Seal** – To enclose an area so that fumigant gas cannot escape too quickly. A good seal will contain a lethal amount of gas for long enough to kill the target pests.

**Self-Contained Breathing Apparatus (SCBA)** – A type of respirator that supplies fresh air from an outside or portable source. Air enters a mask that tightly covers the entire face.

**Shank** – The curved iron bar that connects the working point of a cultivator to the beam or cross bar of the cultivator. You can attach different types of working points to each shank depending on whether the soil is to be stirred, turned, etc.

**Ship Hold** – The area or deck of a ship commonly used to transport cargo.

**Sorption** – The process of taking up or holding a chemical either by adsorption or absorption.

**Subsoil** – The layer of soil located just below the plow layer.

**Tarpaulin** – A semipermeable material used during fumigation to confine fumigant in a specific area during the exposure period.

**Volatile Liquid** – A fumigant that exists as a liquid under atmospheric pressure but evaporates under normal temperatures.

Once you pinpoint a pest problem and decide fumigation is necessary, you are ready to choose a treatment method. There are several types of fumigation. Each has its pros and cons. Your job is to select the best method for a given situation. Your decision will be based on:

- The pest you need to control
- The item, area or structure you need to treat
- The location of the product or condition of the soil
- The product you need to treat or what crop(s) will be planted after treatment
- Your client's budget
- The proximity of the area to other people
- Weather conditions
- The severity of the infestation

All methods of fumigation have one thing in common: they must achieve and maintain an

adequate concentration of toxic gas long enough to kill the target pest(s).

This unit describes the most common methods of fumigation used to treat stored products, whole structures and areas within structures. This unit describes the most common ways to fumigate stored products, whole structures, areas within structures, raw commodities and soil. You will learn how and when each method is normally used. You will learn how to implement each method. You will also discover basic safety considerations associated with each method. With this information, you can make educated decisions.

Finally, you will learn about equipment calibration – its importance and calibration techniques used for soil fumigations.

Remember, fumigants are highly toxic and dangerous. They are reserved for only the most severe infestations. Be sure fumigation is the best option for your situation.

## Fumigation Methods

Raw agricultural products are stored in bins, silos and other structures. They may also be kept in boxcars, trucks or in ship holds for short periods during transportation. Because fumigants can move through tiny cracks and crevices, fumigation must occur in structures that are relatively airtight. Some buildings and boxcars are naturally well-sealed. Others may need fumigation tape, polyethylene sheeting or other materials to make them airtight. Still other structures, particularly those that are leaky, may need to be tarped. Fortunately, several fumigation methods are available.

The two most common methods used to fumigate raw commodities are:

- **Vault Fumigation** – Vault fumigation uses atmospheric or vacuum chambers to treat infested products. Other structures such as truck trailers, boxcars, grain bins, silos and other storage structures can be vaults if they are well-sealed.
- **Tarpaulin Fumigation** – Tarpaulin fumigation places commodities under a tarp or covers and entire structure. Fumigant is released beneath the tarp and held until pest control is complete.
- **Spot (Local) Fumigation** – Spot fumigation is used to treat small items or areas with light to moderate infestations. Spot fumigation is also used routinely to prevent infestations from developing or recurring.

## Vault Fumigation

Vault fumigation treats infested commodities within an airtight or sealed structure. These structures or “vaults,” such as truck trailers, boxcars or ship holds, may serve dual purposes. Others, like vacuum chambers, are specially designed for fumigation. Sealed silos and grain bins are also fumigation vaults. Although you must take basic safety precautions, fumigation in atmospheric vaults and vacuum chambers poses fewer risks than other methods of fumigating agricultural products. These structures are better designed to deliver, contain and exhaust the fumigant.

For simplicity, this unit will discuss three types of vault fumigation:

- Fumigation in atmospheric chambers
- Fumigation in vacuum chambers
- Fumigation in sealed structures

### Fumigation in Atmospheric Chambers

An atmospheric chamber can be any airtight structure under normal air pressure. It is usually a small building located away from other structures. Some are specially built for fumigation. Others are modified from existing structures.

You can construct a suitable, low-cost atmospheric chamber using a gastight room with an appropriate door. A minimum of equipment is required. You will need tools to apply, distribute and remove the gas. Heating may also be necessary. Steam pipes are best and should be able to heat the area to 70°F during treatment. Locate the chamber so that you can easily move goods in and out of it. Also, be sure to minimize hazards to workers and the environment. Atmospheric chambers should not be within or connected to other structures where fumigant passage may occur.

#### Advantages of Atmospheric Chambers

Once atmospheric chambers are built or modified for fumigation, you can use them again and again. Commodities can be moved in and out of the vault without special preparation. Vaults have a constant volume, so you do not have to compute the volume for each treatment. You can permanently install special equipment to monitor fumigant levels.

#### Disadvantage of Atmospheric Chambers

Atmospheric chambers are costly to set up, and they hold a limited amount of product. It

also takes time and money to move commodities into and out of the chamber.

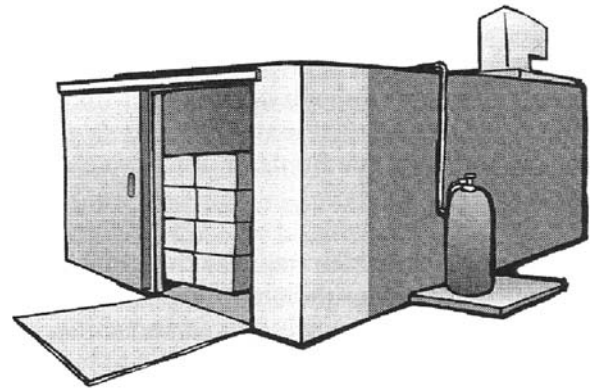

Atmospheric vault

### Fumigation in Vacuum Chambers

Vacuum chambers are large steel structures. Unlike other vaults, treatment occurs in a “vacuum” rather than at atmospheric pressure. In a vacuum, the air pressure is lower. This does two things. First, it denies oxygen to the pest. Under a vacuum, the oxygen level inside a chamber decreases. Pests become stressed and are easier to kill. Second, the vacuum helps the fumigant penetrate the commodity. This may reduce fumigation time from 24 hours to 4 1/2 hours depending on the fumigant used. In addition, by adding an “air-wash cycle” (breaking the vacuum and drawing a second vacuum), aeration after treatment is also fast. Despite its benefits, beware. Some fumigants (such as phosphine) explode under vacuum conditions. Always read the label information to be sure your product is safe to use in a vacuum chamber.

Vacuum fumigation is used to treat densely packed items and other materials that are difficult to penetrate at atmospheric pressures. It is also useful for plant quarantine and products that need to be treated quickly. Do not treat tender plants or produce in a vacuum. Fresh fruits, vegetables and other such items cannot withstand the reduced pressures.

There are two main ways to conduct vacuum fumigation: sustained-vacuum fumigation and restored pressure fumigation. The “sustained-vacuum method” starts when you reduce the pressure inside the chamber and introduce the fumigant. The slightly reduced pressure (vacuum) is held until the end of the treatment. In the “restored pressure method,” you would lower the pressure, introduce the fumigant and then restore the pressure in one of four ways.

1. **Gradual Restoration** – Release the fumigant and then slowly introduce air until

the air pressure returns to normal. This usually takes two to three hours.

2. **Delayed Restoration** – Hold the vacuum for about 45 minutes following discharge of the fumigant. Then, allow air to rapidly enter the chamber.
3. **Immediate Restoration** – Just after releasing the fumigant, rapidly let air into the chamber by opening one or more valves.
4. **Simultaneous Introduction of Air and Fumigant** – Use special metering equipment to release a mixture of air and fumigant into the chamber.

These four techniques to restore pressure are listed in order of effectiveness – number one being the most effective for most situations. The “sustained-vacuum method” falls between methods two and three.

“Air-washing” must follow all vacuum fumigation procedures. This process removes the fumigant/air mixture, then flushes the chamber with clean air several times until it is safe to open the door for unloading. Air-washing is more intensive than aeration. Because vacuum fumigation forces the fumigant into a commodity, sorption of that chemical is strong. Without forcing fresh air into the chamber, the fumigant may remain within the commodity.

Vacuum fumigation requires the same safety precautions as do other fumigation methods. These may include wearing a respirator and using monitoring tools to test for leaks. See Units 6 and 7 to learn more about fumigation.

## Portable Vacuum Fumigation Chambers

When you need to fumigate small amounts of product in several locations, a portable vacuum fumigation system brings added flexibility. A portable unit consists of:

- A vacuum such as “shop vac” or other high-capacity vacuum cleaner
- Two pieces of heavy-duty vinyl sheeting that you can clamp or zip together (similar to food storage bags)
- Fumigation dispensers
- Connecting hoses
- A security lock
- A gas concentration monitoring valve
- A carrying case
- A gas discharge standpipe

Portable systems allow you to develop a vacuum between the layers of vinyl. The vacuum

pulls the vinyl tight around the commodity. Once the vacuum reaches the optimal level, you can apply the fumigant.

## Advantages of Vacuum Fumigation

Commodities fumigated in vacuum chambers require much shorter exposure times. The fumigant can penetrate dense commodities. Vacuum chambers have most of the other advantages of atmospheric chambers.

## Disadvantages of Vacuum Fumigation

Vacuum fumigation in chambers takes a large initial investment. Commodities must be moved into and out of the chambers. You cannot use phosphine or other fumigants that are explosive under a vacuum. In addition, more fumigant is required, and the amount of product that can be fumigated in vacuum chambers is limited.

## Fumigation in Sealed Structures/Tape-and-Seal Fumigation

There are two types of structural fumigation: structural fumigation by sealing, also called “tape-and-seal” fumigation (a type of vault fumigation), and structural fumigation by tarping (a type of tarpaulin fumigation).

Both methods work by turning an entire structure (grain bin, silo or boxcar) into a temporary fumigation chamber. To do this, it helps if the building is airtight. Tape-and-seal fumigation accomplishes this by working only with buildings that are in good repair. Workers find and seal all leaky spots with fumigation tape. The goal is to create a “vault” that is as close to airtight as possible. Structural fumigation by tarping creates an airtight environment by placing a tent over the entire structure. See “Tarpaulin Fumigation” later in this unit for more information on this method.

Tape-and-seal fumigation allows you to treat commodities stored in many building types. You can fumigate products in brick, concrete and stucco buildings that are in good repair if you tape and seal the roof if it is likely to leak. Monitor the fumigant concentrations to ensure that an adequate dosage is achieved to kill the target pest. In addition, when treating commodities in large structures, you must run gas detectors throughout the structure to monitor fumigant levels in different areas. This will ensure that all areas receive an equal amount of fumigant.

## Advantages of Tape-and-Seal Fumigation

Nontarget pests such as rats and mice are usually controlled along with the insects. In addition, little material is needed to make the structure relatively airtight. Unfortunately, this advantage is usually offset by the labor required to find and seal leaks.

## Disadvantages of Tape-and-Seal Fumigation

Building occupants must leave the structure during treatment. You must also remove items that the fumigant may damage. Tape-and-seal fumigations are notoriously leaky. It is easy to overlook vents, cracks, conduits and other areas that may permit gas to escape. The fumigant may diffuse through interior walls, making it hard to maintain the required concentrations of gas. Insects in the exterior walls and eaves may survive if gas levels are too low to penetrate these sites.

## Preparing for Tape-and-Seal Fumigation

Once you decide that tape-and-seal fumigation is necessary, do a thorough on-site inspection. Frequently, the success of a fumigation operation will depend on what you learn, what you decide and how you plan. Ask yourself a number of questions.

### General

- Can you move the infested commodity and treat it elsewhere?
- If removing the infested commodity is not practical, can you fumigate it in place without treating the entire structure?
- What is the volume (cubic feet) of airspace or volume (cubic feet) of the commodity?
- What is the cubic footage of the building? See Appendix B for information on how to calculate volume.

### Inside the Building

- Are there any broken windows that you need to replace?
- Are there cracks in the ceiling, walls or floor that you will need to seal?
- Are there floor drains, sewer pipes or cable conduits that may leak? Many fumigation

attempts have failed because floor drains under stacked commodities went unnoticed. In another case, a fumigant leaked into a telephone cable tunnel that led to an occupied building. A number of people became ill.

- How will you handle ventilation fans, air conditioning ducts and flues?
- Will interior partitions interfere with fumigant circulation?
- Are the interior partitions gastight?
- Can you rely on them to keep the fumigant from entering other parts of the structure?
- Are there parts of the building that are not under the control of your customer?
- Can you shut down these operations during treatment?
- Will the fumigant damage anything in the building?
- Can you remove these items during fumigation?
- If not, can you protect them?
- Where are the gas shut-offs?
- Where are the pilot lights?
- Where are the electrical outlets?
- What is their voltage?
- Will circuits be live during fumigation?
- Can you use the outlets to operate your circulating fans?
- Does the building contain any high-priority items that may have to be shipped within a few hours notice?

### Outside the Building

- From what materials is the structure built? (Fumigants readily pass through certain materials such as wood.)
- Can you make the structure relatively airtight through sealing?
- Will it be necessary to tarp the entire building?
- If you tarp the structure, can you make a tight ground seal?
- Are there shrubs next to the building?
- Will they be damaged by the fumigant or by your digging to create a ground seal?
- Can you move these plants if necessary?

- How far is it to the nearest building?
- Does that building have air conditioning?
- Does it have air intakes that might draw the fumigant inside, particularly during aeration?
- How will you aerate the structure after fumigation?
- Are there exhaust fans?
- Where are the fan switches?
- Are there windows and doors that you can open for cross ventilation?
- Is the structure to be fumigated located where your operations may attract bystanders? If so, consider asking police to assist your own guards.
- Where is the nearest medical facility?
- Do you have the telephone number of a poison control center?

Once you are confident that you have covered everything, prepare a list of things to do. Make a second list of materials that you will need. See Unit 6 and Appendix A for sample checklists. Do not rely on your memory. With the checklists in hand, ask yourself on final question:

What have I overlooked?

## Types of Sealed Structures

### Silos and Grain Bins

Treating grain in silos and grain bins is one of the most common types of raw commodity fumigation. Well-built silos and grain bins may only require sealing to be gastight. Others, especially those made of wood and other permeable materials, may need to be tarped.

When sealing grain bins and silos for fumigation, be sure you find and seal all potential leaks. Proper sealing will often mean the difference between success and failure of a treatment. There are many places in a bin where gas can escape. These include along walls, roof-wall junctures, seams, roof ventilators, bin doors, aeration fans, and through other gaps. When sealing these gaps with fumigation tape, it is often helpful to apply tape primer first. Tape primer coats the surface you plan to seal with a tacky substance. This helps the fumigation tape adhere better. Both brush-on and spray-on primers are available.

Unlike other types of grain storage structures, wooden bins are often too leaky for tape-and-seal fumigation. The loose

construction of wooden bins and the permeable nature of wood can cause gas to escape despite your best sealing efforts. Instead, wooden bins may have to be tarped to retain enough gas for the treatment to be effective. See “Tarpaulin Fumigation” later in this unit for information about this treatment option.

Once a grain bin or silo is sealed, you are ready to release your fumigant. Some fumigants are heavier than air. These chemicals often require special recirculating equipment such as blowers to adequately distribute them throughout a grain mass. Before releasing such fumigants, be sure your blowers are working properly. First, turn them on to establish airflow. Then, introduce the fumigant on the high-pressure side of the blowers. Run the recirculating system until the fumigant is thoroughly distributed.

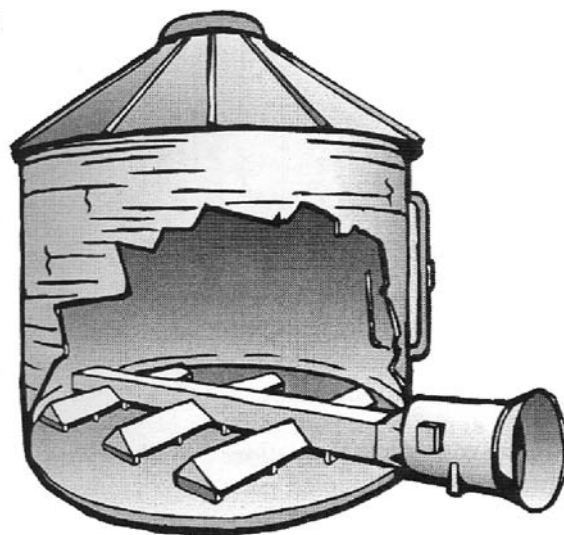

**Grain storage recirculation system**

Some grain storage structures have built-in aeration or recirculation systems. These devices regulate the temperature and moisture content of the grain. During fumigation, you can use them to distribute fumigants throughout the grain mass. Other storage structures may not have such sophisticated systems.

In most cases, if you use fumigants that have good penetrating and distributing power, you will not need special recirculating equipment. Simply apply the fumigant directly into the grain. You can do this while the grain is being stored or as the silo or bin is being filled. If the fumigant comes as pellets or tablets, use a special probe to insert it into the grain mass. If you add the pellets to the grain during filling, use an automatic pellet/tablet dispenser. Fumigant manufacturers often supply these probes and dispensers.

No matter which type of fumigant you use, always wait for a still day to fumigate. Winds around a grain storage structure create pressure gradients across the grain surface. This can result in rapid loss of fumigant. In some cases, using polyethylene or plastic-coated nylon to cover the top of the grain after treatment will help to ensure an effective treatment.

As with other types of fumigation, the fumigant, formulation, dosage and equipment vary depending on the commodity, the storage facility and other factors. Make sure the fumigant is labeled for the intended use. Follow all instructions in the label information exactly.

## Tobacco Warehouses

Tobacco warehouses are constructed of many types of materials including metal, wood, brick and concrete block. Some are closed-sided. Others are louvered-sided to allow for airflow. Some have roofs with skylights. Others have solid roofs, ridge vent roofs or other designs. You can find tobacco warehouses in residential areas, industrial areas, commercial areas or areas that have little transit traffic. As the fumigator, you must consider all of these factors during treatment.

To prepare a tobacco warehouse for fumigation, start by sealing the structure as tightly as possible. In some cases, you will need to cover and seal the whole building. In other warehouses, you may only need to cover the openings in the building, such as doors, windows and vents. Polyethylene sheets should be 2 to 4 mils thick. This thickness will cling to the building better than thicker material. Use fumigation tape to seal small cracks and holes.

After sealing the building, check for leaks. Place thermal smoke generators against the walls and sealed openings inside the building. Turn them on and have someone outside mark the place(s) where smoke escapes. Reseal those spots.

In warehouses, producers usually store tobacco in wooden or cardboard cases, burlap bales or barrels called "hogsheads." The tobacco is packed tightly. To reach the insects in the center of a load, the fumigant must have good penetrating power. Currently, phosphine gas is the most common and successful fumigant used in tobacco warehouses. If you seal the warehouse well and apply the correct dosage, phosphine gas can penetrate tobacco containers with no mechanical aid. See Unit 8 for more information on phosphine gas.

During fumigation, it is important to monitor fumigant levels inside the tobacco. This will help you determine its penetration rate. It will also alert you to any leaks. Set up your monitoring equipment before releasing the fumigant. Choose a commodity container far from the fumigant release site. Then insert a metal tube into the container. Attach a plastic tube to the metal tube. Run the plastic tube outside of the building. Take gas readings with a detector specific to the fumigant you are using. Gas concentrations are measured in parts per million (ppm). If the concentration of gas is the right ppm at the end of the exposure period, all pests should be dead. Treatment is complete. Read the label information of each product you use to determine the dosage and exposure times.

Sometimes only part of the contents of a tobacco warehouse needs treatment. In this case, follow the procedures for tarpaulin fumigation later in this unit.

## Wheeled Carriers

*NOTE: It is illegal to transport goods over public roads or highways if those goods are undergoing fumigation or have not completely aerated.*

Fumigating products inside wheeled carriers such as boxcars and truck trailers is another form of vault fumigation. This method saves time and labor. It avoids extra loading and unloading. It controls the pests in the commodity and ensures that live pests do not remain after unloading. In addition, fumigation of incoming loads prevents the introduction of pests into uninfested areas.

Boxcars and truck trailers are ideal vaults for fumigation. Wheeled carriers must be airtight for fumigation to be successful. Fumigation must stay inside the truck or boxcar long enough to control the pests. Well-built structures can be made relatively airtight by sealing them with fumigation tape or liquid adhesive. Structures with large holes or cracks, or structures made of permeable materials such as wood, may need to

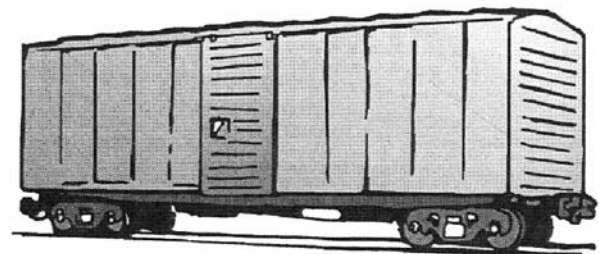

Boxcar

be tarped. See “Tarpaulin Fumigation” later in this unit to learn about this type of fumigation.

First, inspect and clean the boxcar or truck trailer while it is empty. Look for small holes or cracks that may allow fumigant to escape. Use fumigation tape, liquid adhesive or caulking to seal any gaps. Then seal the door that will not be used for loading. Secure a precut 2- or 4-mil polyethylene sheet over the entire door. Compute the volume of the container to determine the dosage. See Appendix B for information on how to calculate volume.

Next, apply the fumigant. Every product is different. Read the label to determine how best to apply the product you are using.

Next, cover the last door with polyethylene before closing and sealing it with fumigation tape. As required by law, place a warning sign on each door. Return any unused fumigant to a locked chemical storage area. Dispose of empty fumigant containers according to the directions in the label information. See Units 6 and 8 for more information on the safe use and disposal of fumigants.

## Ship Fumigation

Like fumigation of wheeled carriers, ship fumigation treats goods while they are still on board. This avoids extra loading and unloading. It controls the pests in the commodity and ensures that live pests do not remain after unloading. Fumigation of incoming loads also prevents the introduction of pests into uninfested areas. This is particularly important for products arriving from overseas.

Ship fumigation involves many people. Close cooperation with the responsible ship officer, ship agent, USDA official and Coast Guard inspector (if involved) is essential. You may also need to notify the port authority and the local fire and police departments.

Shipboard fumigation is highly specialized. The problems encountered and techniques used in ship fumigation are unique. In many cases, you may want to hire a company that specializes in ship fumigation.

## Tarpaulin Fumigation

Tarpaulin fumigation treats single pallets of goods or entire structures. It works by placing a semipermeable tarp over an infested product or structure, sealing the edge and then releasing fumigant beneath the tarp. Sometimes, you may need to treat an entire building. This type of tarpaulin fumigation is normally used to control drywood termites or wood-boring beetles.

## Advantages of Tarpaulin Fumigation

You can use tarpaulin fumigation to treat a variety of items. It is particularly useful when only single pallets or groups of commodities are infested. Instead of fumigating an entire warehouse full of goods, tarpaulin fumigation allows you to treat only those items that are infested. This saves time and money. In addition, you can tarp and treat individual items or groups of items where they stand, if it is permitted by the label information. This also saves time and money. Because you can clamp together many sections of tarp, there is no limit to the size of the stack or structure that can be covered.

## Disadvantages of Tarpaulin Fumigation

The biggest problem with tarpaulin fumigation (when covering entire structures or treating products outdoors) is the weather. Weather conditions can delay fumigation. If there has been a recent heavy rain, the roof of a structure may be too slippery for safe work. Structures with wood roofs or concrete block-houses can sorb enough moisture to cause problems after the tarps are placed on the building. In addition, if the temperature is below the labeled minimum, you must delay treatment until the structure and commodity within it are warm enough to comply with the label instructions.

## Types of Tarpaulins

An important aspect of tarpaulin fumigation is the type of tarp you select. Some tarps are specially made for fumigation, such as impregnated nylon. Others are more generic but equally effective, like sheet polyethylene. Each material has its pros and cons.

Impregnated nylon tarps are strong. They resist ripping and are reusable. In addition, you can clamp or tape together many sections of impregnated nylon tarps. This allows you to cover structures and commodity loads of almost any size. Unfortunately, impregnated nylon tarps are expensive. They are also heavier, which makes them more difficult to use.

Polyethylene sheeting comes in a variety of thicknesses. Some are reusable and some are not. Thinner sheets (3 mil or less) can be used once and are for indoor treatments only. Outdoors, you can use 4- and 6-mil polyethylene. Six-mil sheets can be reused if they are not worn or ripped excessively. To join together

sections of polyethylene, use fumigation tape instead of clamps. Thinner sheets of polyethylene are often preferred to nylon tarps because they are less expensive and disposable. However, because they can tear easily, you must use them with care.

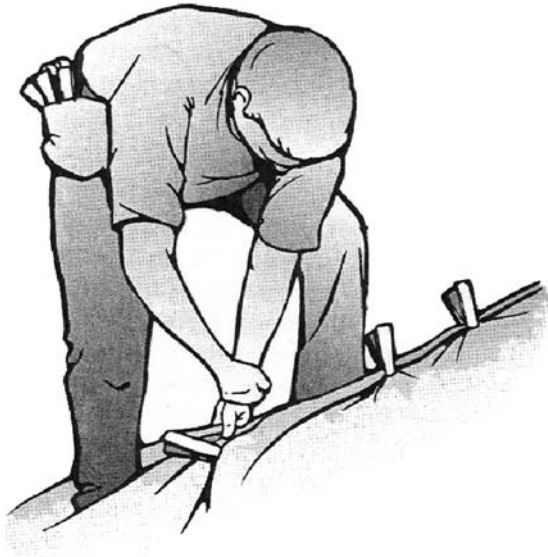

## Ground Seals

In addition to proper tarp selection, also consider the type of ground seal you will need. If they are smooth, concrete and asphalt surfaces provide the base for a good ground seal. Wood surfaces do not. With wood, and frequently with soil surfaces, it is necessary to place a section of the tarp beneath the product to be fumigated as well as over the top of the product. Otherwise, gas may escape through the wood or soil.

There are several ways to obtain a good ground seal. First, cover the infested product, allowing at least 18 inches of tarp to skirt out from the base. Then, lay loose sand, sand snakes



or water snakes to hold the skirt to the ground surface. Snakes are tubes of cloth or plastic filled about three-quarters full with sand, gravel or water. All types of snakes should overlap each other about 1 1/2 feet.

Sometimes you can attach adhesive fumigation tape directly to the floor. However, you still need sand, gravel or water snakes to prevent the tarp from blowing off during treatment. Occasionally, you may need to treat an item that is too close to a wall to obtain a good ground seal. In this case, move the item and seal the tarp properly to the floor.

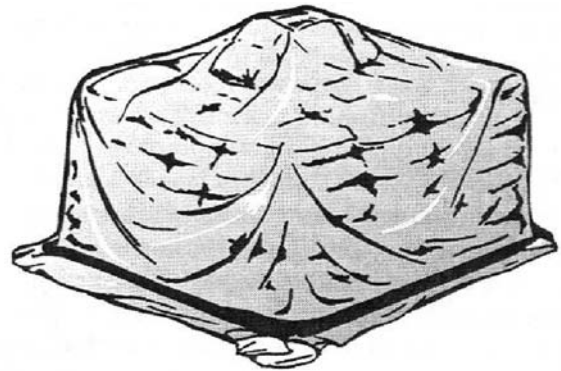

## Tarping Individual Items

Frequently, only single pallets or groups of commodities need treatment. With tarpaulin fumigation, you can cover and fumigate these items in place or at a nearby location.

## Basic Procedures

First, erect tarp supports one to two feet higher than the stacked commodity. This will create an air dome. An air dome ensures adequate gas circulation during fumigation.\* Secure gas introduction tubes above the commodity. Place polyethylene sheeting under the outlet of the gas introduction tube. This will protect the commodity from any liquid fumigant that may accumulate during discharge. Next, pad all corners to prevent the tarp from tearing. The lighter the tarp material, the greater the chance for rips.

If the stack is large, use nonsparking fans to ensure adequate gas circulation. Turn on the fans for 30 minutes to one hour after introducing the fumigant. Run tubing from various positions in the stack (usually one located high in the stack, one at an intermediate location and one at a low location) to the point where you will sample gas concentrations. Then place and seal the tarp to the floor. Determine the volume of



the space beneath the tarp to calculate the amount of fumigant to use. See Appendix B for information on how to calculate volume.

*\*NOTE: The air dome, tubing and fans are neither necessary nor recommended when using aluminum phosphide.*

## Indoor Tarpaulin Fumigation

Tarpaulin fumigation is easiest and most effective indoors. Protection from wind and rain is critical. However, most indoor treatments require you to evacuate the entire building. Some fumigants may allow work to continue in other parts of the building as long as the treatment area remains clear. Of course, you must post warning signs and monitor the area regularly.

If the commodity you wish to treat is in an unsuitable indoor site, it may be better to move it to another indoor location than to fumigate outdoors. Make this decision when you first inspect the structure. For ease of movement, place all commodities on pallets for fumigation.

## Outdoor Tarpaulin Fumigation

The same procedures outlined for indoor treatments apply to fumigation outdoors. The difference is that outdoor tarps must be stronger and more durable. If you use polyethylene, it must be at least 4 mils thick. Six-mil sheets are better. The color of the tarp also makes a difference. Clear polyethylene tends to become brittle from ultraviolet rays of the sun. In some cases, rays of sunlight can concentrate through water drops on clear tarps and cause fires. If you plan to keep the polyethylene tarp in place after fumigation is complete or if you will reuse it, consider black polyethylene. It is more resistant to sunlight and is not transparent. However, there are some dangers with black tarps. For example, if the tarp spans several stacks, it may conceal gaps between the stacks or other voids. Persons working on top of the tarp must be careful not to fall through. Once fumigation begins, a fall could be fatal.

There are several challenges with outdoor fumigation. First, it is more difficult to obtain a good ground seal outdoors. Sand and water snakes are often less effective because the ground is usually porous and uneven. Instead, place a layer of loose sand on the tarp skirt to obtain a good seal. You will also need to plan for bad weather. If you know it will be stormy, delay fumigation. Place braces over the product (but under the tarp) so that rain will not accumulate in any low spot. Also, place sand snakes or sandbags over the tarp to protect it against wind.

## Tarping an Entire Structure

Sometimes, you may need to treat a commodity by tarping an entire structure. This type of tarpaulin fumigation is normally used to treat flat grain storage buildings or any extremely leaky, poorly constructed structure that cannot feasibly be sealed.

## Basic Procedures

When fumigating an entire structure, good preparation is critical. Remove all items that the fumigant may damage or that the label information requires. Evacuate the building for the entire fumigation and aeration period. Turn off pilot lights, flames, electrical heating elements and electric motors. If the commodity you plan to treat is packaged in bags or other containers, be sure these materials will allow the fumigant to penetrate and treat the commodity.

Place tubing to draw air samples from several places within the structure. Use these tubes to administer the fumigant and test its concentration during the treatment and aeration. It is best to introduce the fumigant at several locations. Place electric fans so that the fumigant will circulate throughout the structure and achieve rapid equilibrium. Local fire authorities may require the use of nonsparking fans.

If landscape plants are too close to the structure to permit a good ground seal, move the plants. Pad all edges of the structure that may puncture or tear the tarp. To be safe, ask all workers to wear shoes with nonskid surfaces. Slips or falls can be very dangerous during fumigation. All ladders should be strong and braced. Use these to carry tarp sections to the rooftop. If you use impregnated vinyl or nylon tarps, roll together the edges of two tarp sections. Place clamps approximately 8 inches apart (4 inches apart if windy) along the seam. Drop the tarp over the sides of the structure. Complete any additional clamping or taping at this point.

Excessive "billowing" of a tarp can speed the loss of fumigant from a structure. Billowing occurs when air beneath a tarp causes the tarp to bulge outward. Prevent this by keeping the tarp tight against the structure. For example, if the building top is flat, use sand snakes to hold down the tarp. If the roof is peaked, throw weighted ropes over the tarp. Draw the tarp as close to the building as possible. One technique involves a high-capacity electric fan. Place the fan in one doorway and direct it outward. This may create a partial vacuum that will draw the tarp against the structure. Then, you can gather and tape down the excess material at the corners of the structure.

As in any fumigation, the ground seal is very important. The ground should be level and free of vegetation. If the soil is porous or dry, soak the soil around the perimeter of the building with water. This will help prevent fumigant from escaping through the soil. Make sure the tarp skirt is at least 24 inches and weighted down by loose sand, water snakes or sand snakes. If you use water or sand snakes, double or triple them in windy weather.

## Spot (Local) Fumigation

Spot fumigation is the short-term treatment of machinery and small storages with toxic gases. It is used to control pests that infest whole foods and food particles that remain within processing equipment. Spot treatments work by interrupting the life cycles of insect pests. Since one or more stages of the insect (egg, larvae, nymph, adult) may survive, you must repeat spot fumigation regularly to maintain control. Use spot fumigation to control stored product pests in:

- Bins, silos and holding tanks
- Elevator boots and heads
- Filters
- Conveyors
- Spouting
- Purifiers
- Food processing equipment
- Sifters, rollers and dusters
- Related equipment in mills, food and feed processing plants, breweries and similar industries

Spot fumigation is most useful where there is an accumulation of static or nonmoving stock. In an industrial setting, the following sites are susceptible:

- In elevator boots behind the feeder rolls on older style roll stands
- On the feeder rolls on newer type rolls
- In purifier conveyors on old style wooden purifiers
- Pickup converters, screw conveyors or the air chambers and feeders of the newer type Buhler or Miag purifiers
- The rear side of Draver feeders
- The top of each sifter section
- The inlets of feed finishers
- Directly below the elevator heads in each side of an elevator leg
- The canted or sloped area directly beneath the elevator head pulley (in most conventional or bucket type mills, this area is not accessible for cleaning and is often overlooked during spot treatments)
- Automatic flour and feed scales
- The inlets leading to cyclone dust collectors

- Vertical air trunks
- Horizontal air trunks

## Advantages of Spot Fumigation

Insect infestations are usually not uniform. They concentrate in specific locations within equipment and storage areas. Spot fumigation allows you to treat only those areas where insects exist. This saves time and money, and it puts less fumigant into the environment.

## Disadvantages of Spot Fumigation

Spot fumigation is often labor intensive. Without fumiports, you must cut up and insert prepackaged fumigant, such as phosphine Prepac, into the machinery at several locations. In addition, when treatment is complete, you must retrieve each Prepac or risk contaminating product during future processing. Spot fumigation can also be time-consuming. Calculating the volumes of several small locations is cumbersome. Finally, disposal of spot fumigants like phosphine is difficult because you must deactivate the chemical before transporting it off site.

## Basic Procedures

Several things can affect the success of spot fumigation. Most important is your understanding of the equipment you treat and the airflow patterns within a warehouse. Always review diagrams of the facility and inspect the machinery. Determine whether you can make the site sufficiently gastight. Next, develop an application plan. Be sure your plan includes:

- The necessary staff and supplies.
- An application route. This route should be quick and efficient. It should also minimize applicator exposure.
- Security provisions during treatment. Post appropriate signage and notify the facility's personnel. Do not allow unauthorized persons to enter the treated area(s) prior to aeration.
- A procedure for sealing the equipment before treatment. Repair machinery, transfer lines, bins or other equipment before treatment. This may improve the equipment's ability to retain gas.
- Dosage rates and application points.
- Safety provisions. Respiration protection is often required during spot fumigation. Always preplan ways you and other applicators can reduce your exposure to the fumigant. These methods may include wearing respiratory protection, working near an open window or using fans or forced ventilation.

- A record or log detailing the procedure. The log should include dates, dosage rates and application points.
- Recommendations for the permanent installation of fumiports. Place fumiports inside the equipment to eliminate the possibility of contamination.
- A procedure for monitoring fumigant concentrations. Using an approved gas detector, take readings at regular intervals. Note fumigant concentrations during application to be sure fumigant levels get high enough for long enough to kill the pest. Note fumigant concentrations during aeration. Allow reentry only when gas levels are safe.
- A procedure for recovery, deactivation and disposal of the fumigant when using phosphine. This plan must include emergency monitoring procedures.

Clearly mark all application points, particularly those that may not be visible from the floor level. Also, mark points where ladders are needed to reach overhead areas. Prepare a checklist or chart for each facility. Show the location and number of application points on each floor. As you treat each point, check off the appropriate location on the chart. In this way, you can be sure you did not miss any points before moving to the next floor.

Before treatment, run the machinery to empty the process stream. In mills, turn off the feed and allow the mill to run for 30 to 45 minutes. During this period, use rubber mallets to tap on the spouting, elevator legs and sifters. This will help to loosen product that is trapped inside. Check outlet channels in the sifters to be sure they are not blocked or choked.

Next, seal the equipment. This will prevent fumigant from escaping. Eliminate drafts inside the equipment by closing off sections that have openings. Then, seal these openings with tape, caulk, tarps or other materials. Seal dust collector vents with polyethylene sheeting or large plastic bags. Close dust collectors and filter vents to keep the fumigant within the machinery. Thermal currents and drafts can cause a spot fumigation to fail. Gas may escape before reaching a lethal concentration within the machinery.

While spot fumigation is less intensive than other methods of fumigation, proper safety is equally important. During application, open windows in rooms that house equipment to allow ventilation. When possible, use a fan or hood to reduce your exposure. Read the label information of each product you use to determine what PPE is required. Approved respiratory protection is required for many spot fumigations. See Units 5 and 6 to learn more about fumigant safety and respiratory equipment.

## Aeration After Fumigation

Aeration follows both vault and tarpaulin fumigation. It is the process by which fumigated air is replaced with fresh air. This can occur in a large warehouse or in an individual piece of equipment. Sometimes aeration involves opening doors and windows. Other times you can use fans and ventilators. Aeration procedures vary according to:

- The fumigant you use
- The area in which you fumigate
- The commodity(ies) that you treat

Every situation is different.

Proper aeration is important for your safety, the safety of your crew and the safety of your clients. Read and follow the instructions in the label information for your product exactly.

## Factors Affecting Aeration Time

The rate of aeration is affected by several factors. Three of the most important factors are:

- The rate of air exchange
- Air temperature
- Sorption and desorption

## Rate of Air Exchange

The rate of air exchange within a treated area is the most important factor affecting aeration. The faster air flows through a structure, the faster aeration can occur. Exchange rates are proportional to wind speed and to the size and layout of the fumigated area. In atmospheric chambers, an exchange rate of one “air change” per minute is desirable. An air change occurs when 100 percent of the air in a given space is replaced by fresh air. Nonsparking fans are useful for this purpose. They also help to stir up the air in “pockets” or “dead spaces.” Areas loaded with product aerate more slowly than empty areas.

## Temperature

Temperature can also affect the speed of aeration. As temperature increases, the rate of aeration increases. This is because higher temperatures increase the rates of diffusion and desorption of fumigants. For example, when you aerate areas during colder months, you may use cold outside air. These lower air temperatures will slow desorption. The rate of diffusion will also decrease. A longer aeration time will be needed. It may be necessary to close the area

and heat it to 76°F (24°C) (the optimal aeration temperature for most fumigants). Then repeat the aeration process to adequately remove the fumigant.

## Sorption and Desorption

As you learned in Unit 3, sorbed fumigant cannot control pests. It is adsorbed and/or absorbed by materials in the treated area. Still, you must remove it during the aeration process. Some commodities are more sorptive than others are. Some fumigants are more subject to sorption than others are. The greater the sorptive capacity of the fumigant and the product you are treating, the longer it will take for the product to completely aerate.

To determine how sorptive a fumigant is, read the label information. Then follow these two rules of thumb:

1. Generally, the lower the boiling point of a fumigant, the lower the sorption rate, and the more rapid the aeration.
2. The greater the surface area of the commodity(ies) being fumigated, the greater the sorption rate, and the longer the aeration period needed for desorption. For example, the surface area of wheat grain is high. (A load of wheat grain consists of many small pieces, each with a surface area. Together, these add up.) Because of its high surface area, the desorption rate of wheat grain is slow. It is usually advisable to hold wheat grain an additional 24 hours after the satisfactory aeration period. Other highly sorptive materials include clover seed, milo (grain sorghum) and burlap bags (used to hold many stored products). You will need to increase aeration times when treating these materials as well.

## Aeration Procedures

Procedures for aeration vary with the fumigant, the area and the product(s) being fumigated. Read the label information for aeration procedures specific to each product that you use. Follow the instructions exactly.

### Aeration of Fumigation Chambers

The way you aerate a fumigation chamber depends on whether the chamber is indoors or outdoors. When a fumigation chamber is within a building where people are likely to be present, install intake and exhaust pipes for safe aeration. These pipes lead to the outside. The intake

pipe will draw fresh air in while blowing fumigant-treated air out. Turn on air circulation equipment in the chamber to exchange air between the chamber and the outside.

When a fumigation chamber is outside, aeration is straightforward. Simply open the door slightly and turn on the blower. Be sure to prop open the door so it does not accidentally close. If the door closes, the partial vacuum created by the blower may damage the chamber. Channel the air from the blower to the outside of the chamber.

Do not stand near the chamber door or exhaust when the blower is on. Check gas levels regularly during aeration. Be sure to use a gas detector that is approved for the product you are using. If fumigant levels are too high, stay out of or away from the treated area unless you are wearing the appropriate respiratory protection.

### Aeration of Grain Bins and Silos

Aeration of grain in bins and silos depends on the type of fumigant you use. When aerating chemicals that require recirculation systems, disconnect the return air duct and operate the ventilation system until the exhaust air is free of fumigant. Check fumigant levels with an approved gas detector. Do not use detectors that rely on an open flame around grain bins. When grain gases and dust approach a fire, an explosion can result.

If recirculation systems are not required, simply open all vents and doors. Use nonsparking fans to move fresh air into the structure and pull the fumigant out. If you use pelleted fumigants, the grain will aerate and residual dust from the fumigant tablets will be removed during normal handling of the grain.

### Aeration of Wheeled Carriers

To aerate wheeled carriers such as truck trailers and boxcars, open all doors and vents to promote as much air circulation as possible. Allow the structures to air out for at least 30 minutes. Be sure to wear respiratory protection during aeration as directed by the label information. Always check gas levels with an approved gas detector before reentry.

### Aeration of Buildings

After fumigation, aerate tobacco warehouses and other buildings by opening doors and windows and turning on ventilators. First, open ground floor windows and doors from the outside. Allow buildings to air out for at least 30 to 60 minutes before entry. Then open other windows and doors. Check detectors to be sure

fumigant levels are safe. Read the label information for other aeration requirements.

At the beginning of the aeration procedure, enter the building only for short periods. Always enter in pairs and wear approved respirators. Once inside, open doors and windows on the first floor first. Target windows that provide thorough cross-ventilation. Then return to the outside. If ground floor ventilation occurred before entry, work upward floor by floor. Open windows. Turn on nonsparking fans and allow them to run until aeration is complete. Take concentration readings to determine if exposures are within allowable limits.

After the building has been partially aerated, reenter with a partner wearing approved respirators. Open as many of the remaining windows as needed to complete aeration.

When the building has completely aerated, begin testing gas levels. Using approved detectors, test confined spaces with poor airflow, stacked commodities and other items to make sure that no gas is remaining. Aerating the building and its contents is extremely important. Follow the directions in the label information closely. The first rule of reentry is to “check it first.”

## **Tarpaulin Aeration**

Safe tarpaulin aeration can be trickier than it seems. When aerating loads under tarps on still, humid days, follow these steps. Place a blower on one end of the load. Make an opening

on the opposite end by lifting the tarp. Then turn on the blower and discharge the fumigant. If a breeze or steady cross-ventilation is available, a blower may not be necessary. If you choose not to use a blower or cross-ventilation, aerate the commodity by lifting the tarp at the corners. Then, slowly raise the sides until the tarp is completely removed.

If aeration occurs outside and there is a breeze, pay attention to which way the breeze is blowing. Always lift the end or side of the tarp opposite the direction of wind movement first. Then lift the portion of the tarp on the windward side. If the first opening is on the windward side, fumigant vapors will be forced backward and may endanger workers.

Wear a respirator or gas mask during all phases of tarpaulin aeration. Evacuate occupants other than fumigation workers before aerating tarped products.

After all types of aeration, collect all empty fumigant containers, packaging materials and solid residues (such as those from metal phosphide fumigants). Transport these materials to an appropriate site for further deactivation and disposal. Follow the disposal instructions outlined in the label information.

For fumigation and aeration to be safe and effective, you must select the appropriate fumigation method and follow the procedures outlined in this unit. You should also know how to select and use the equipment described in Unit 7.

## Test Your Knowledge

**Q. What is the objective of all methods of fumigation?**

- A. To achieve and contain an adequate concentration of the gas for the time needed to kill pests.

**Q. Name the three main types of fumigation.**

- A. 1. Vault fumigation  
2. Tarpaulin fumigation  
3. Spot (or local) fumigation

**Q. Describe two types of vaults used for fumigation.**

- A. 1. Vacuum chamber – A large steel structure in which fumigation is conducted at a reduced air pressure.  
2. Atmospheric chamber – A small, isolated building built or modified for fumigation at normal air pressure.

**Q. Name several structures that can be made into fumigation vaults by sealing them with tape or a tarpaulin.**

- A. 1. Wheeled carriers (boxcars, truck trailers, etc.)  
2. Grain bins  
3. Silos  
4. Tobacco warehouses  
5. Ship holds

**Q. What is the biggest problem with tape-and-seal fumigations?**

- A. They are notoriously leaky.

**Q. True or False: Impregnated-nylon tarps can be used repeatedly due to their strength.**

- A. True.

**Q. Why is it important to avoid fumigating grain bins and silos during windy days? How can you prevent these problems?**

- A. Winds around grain-storage structures create pressure gradients across the grain surface. This can result in rapid loss of fumigant. By covering the grain with polyethylene or plastic-coated nylon after

treatment, you can help to ensure effective fumigation in some situations.

**Q. What fumigant is most commonly used to treat stored tobacco? Why?**

- A. Currently, phosphine gas is the most common and successful fumigant used in tobacco warehouses because it has excellent penetrating abilities. In warehouses, producers usually store tobacco in tightly packed loads. To reach the insects in the center of a load, the fumigant must have good penetration power. If the warehouse is well sealed and the correct dosage is applied, phosphine gas can penetrate tobacco containers with no mechanical aid.

**Q. Describe how you would achieve an adequate seal when performing tarpaulin fumigation on a pallet of goods.**

- A. Cover the pallet of goods. Allow at least 18 inches of the tarp to skirt out from the base of the stack. Place overlapping sand or water snakes on the tarp around the perimeter of the stack. Try to work on a level surface.

**Q. How is outdoor tarpaulin fumigation different from indoor tarpaulin fumigation?**

- A. When fumigating outdoors, the tarp must be of stronger material. Obtaining a good ground seal is more challenging. You must protect against unexpected bad weather outdoors. In general, indoor tarpaulin fumigation is preferred.

**Q. What information do you need to safely aerate a fumigated space and its contents?**

- A. Rate of air exchange, temperature and the desorption rate.

**Q. Under what conditions can you enter a partially aerated structure?**

- A. If you are wearing a respirator that is approved for the fumigant you are using and if you are accompanied by at least one other person.

**Q. Describe how to aerate a tarped stack of commodities.**

- A. Place a blower on one end of the load. Make an opening on the opposite end by lifting the tarp. Then turn on the blower and discharge the fumigant. If a breeze or steady cross-ventilation is available, a blower may not be necessary. If you choose not to use a blower or cross-ventilation, aerate the commodity or area by lifting the tarp at the corners. Then, slowly raise the sides until the tarp is completely removed.

**Q. Tarping and fumigating an entire structure is used to treat what types of insects?**

- A. Drywood termites and wood-boring beetles.

**Q. Spot fumigation is primarily used to treat \_\_\_\_\_.**

- A. Infested processing machinery and equipment.

## Fumigation Methods – Soil

When other methods fail, soil fumigation can protect plants from insects, diseases, nematodes and weeds. These pests can occur in crop fields, nurseries, orchards and other commodity production areas. Each situation requires a different method of fumigation.

## Fumigant Movement Through Soil

To understand how soil fumigants work, you must understand soil. Soil consists of mineral particles, organic debris, water and air. Spaces, or pores, exist as areas between the particles that make up soil. These areas are filled with air and a film of water that surrounds soil particles. Soil fumigants diffuse through soil by moving outward from the point of injection through the spaces between soil particles. Diffusion of fumigants through soil air space is not affected by gravity. Once injected, the size and distribution of soil air spaces is a major factor determining where a fumigant goes. The larger and more continuous soil air spaces are, the farther and faster fumigants move. This movement will determine how much soil the fumigant will contact in a treated field.

As fumigants move through soil air space, they dissolve into the film of water that surrounds soil particles. Soil insects move through the air spaces in soil, whereas nematodes and disease-causing organisms live in this aqueous film. The amount of time a lethal concentration of fumigant remains in soil air spaces determines how well a treatment will control soil insects. Disease and nematode control depends on the amount of time a lethal concentration of

the fumigant remains in soil water. This critical combination of fumigant concentration and time is called the “dosage.” Weeds are killed by taking up lethal amounts of fumigant when they absorb soil water.

## Formulations of Soil Fumigants

Soil fumigants form gases that diffuse through soil under normal temperatures and pressures. Some fumigants, such as methyl bromide, must be kept under pressure in order to remain a liquid. These “liquefied gases” change from liquid to gas when released from their pressurized containers. Other fumigants, such as chloropicrin, exist as liquids under normal temperatures. These “volatile liquids” are injected or incorporated into soil as liquids that then vaporize and diffuse through soil. They penetrate plant roots and kill nematodes and pathogens that survive in buried plant debris. Volatile liquids are also able to penetrate the soil to greater depths than other pesticides. A third type of soil fumigant is “moisture activated.” For soil applications, these products come as liquids, microgranules or powders that release gas when exposed to moisture. Metam sodium and dazomet are examples of moisture-activated fumigants.

## Application and Containment of Soil Fumigants

Application and sealing methods differ depending on the type of fumigant you use. Every situation is different. Always read the label for specific information about the product(s) you use. A few basic rules apply.

Soil fumigants will escape from the ground into the air unless you seal the surface during and/or after treatment. In some situations, you will need to place plastic or a tarp over the treated ground. Other treatments may only require soil compaction or heavy irrigation to seal the soil.

For example, you must cover outdoor seedbeds with a polyethylene or a plastic-coated nylon tarp when applying liquefied gasses. For large areas and for vegetable crops, apply the gas in a single operation as the tarp is laid. First, lay the tarp over many smaller areas, such as for tobacco plant beds. Then, release the fumigant by puncturing a small, pressurized container under the tarp. Be sure to distribute the fumigant evenly beneath the plastic or nylon cover.

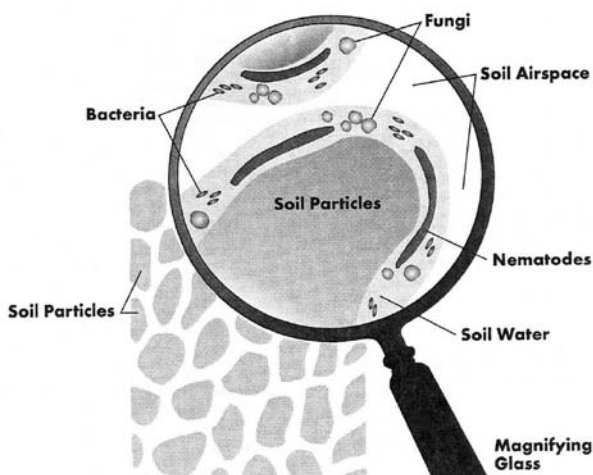



Thoroughly seal the edges of the cover along the margins of the treatment area. The fumigant will penetrate the soil from the top down.



**Sealing tarped soil**

You can also inject soil fumigants directly into the soil between 6 and 18 inches below the soil surface. In these cases, plastic or tarps are rarely used to seal in the fumigants (particularly volatile liquids). Instead, you will use the soil to seal the treated area. When treating only the plant rows, “hill up” the soil above the point of injection as you inject the fumigant. These strips of hilled soil are your planting areas, the areas you want to treat. While fumigants do escape from these strips more quickly than if the soil was tarped, the fumigants must diffuse upward through the eventual root zone. As they do this, they will pass through the soil slowly enough to kill any pests that may be present. When treating entire fields (for example, broadcast fumigation), seal in the gas immediately after treatment by dragging a heavy object across the field to compact the soil.

When applying granular fumigants, spread them uniformly over the surface of the soil. Incorporate the pellets into the soil by cultivating the treated area. Then, seal the area by tarping or by irrigation. Irrigation works by flooding the area. This increases the amount of fumigant that remains in the soil and decreases the amount that escapes to the atmosphere before it kills the target pest.

## Methods of Soil Fumigation

You can use soil fumigation to control pests in agricultural fields, in seedbeds and small areas, at tree sites, in subsoil and in greenhouses.

Apply fumigants to warm (above 50°F), well-tilled soil before planting. To be effective, fumigants must spread throughout the soil. Once the fumigant contacts a pest, the amount of fumigant must increase to a toxic level and remain at that level until the pest is dead. After

the target pests die, the fumigant level must decrease before it is safe to plant or seed a crop. Because this process takes time, “waiting periods” exist for all fumigants. The waiting period for a soil fumigant is the time between application and when a crop can be planted or seeded without crop injury. The waiting period allows the fumigant to spread throughout the soil, kill the target pests and dissipate from the site.

## Field Treatments

Agricultural fields are usually treated with volatile liquids. However, liquefied gases are used extensively in some cropping systems.

You can apply soil fumigants to agricultural fields in a number of ways. The two most common methods are broadcast treatments and row treatments. In both cases, you will need to cultivate the field before treatment. This will loosen the soil to a good “seedbed condition,” eliminate clods and break up any organic debris. Soil temperatures should be about 50°F or higher. The soil should also be relatively moist. Soil with appropriate moisture will just barely retain its shape after you squeeze it in the palm of your hand.

## Broadcast Treatment

Broadcast treatments allow you to fumigate whole fields. This may be necessary if/when it is not practical to fumigate only a portion of a field or when you must reduce populations of the target pest throughout a field. Broadcast fumigation also enables a producer to cultivate a treated field without worrying about contaminating the treated area with untreated soil. Unfortunately, broadcast treatments are usually expensive. They also release a lot of chemical into the environment. Before initiating a broadcast treatment, be sure it is necessary.

Broadcast fumigation injects fumigant through closely spaced chisels or shanks pulled behind a tractor. The equipment used includes several rows of injectors, usually spaced between 6 and 12 inches apart. This close spacing ensures that the amount of soil treated from each point of injection overlaps and that all of the soil above the point of injection is fumigated. Fumigant is released at the bottom of each injector so that



**Chisel/shank**

the point of injection is about 6 to 8 inches below the soil surface. A pump, nitrogen gas or gravity flow pushes the fumigant out through the injectors.

You can also apply some moisture-activated fumigants to entire fields through sprinkler irrigation. To use these products, spray or drop them onto the soil surface and then incorporate them into the soil by cultivation or irrigation.

## Row Treatment

Row treatment is the most economical method of fumigating fields. It involves treating only the portions or “rows” of a field that will be planted. To treat crops that will be planted in rows, use one or two chisels or shanks to inject fumigant into each row where the crop will be planted. Seal the area by lifting, shaping and firming the soil over the chisel trace during fumigation. Additional sealing of the soil surface is not necessary. After treatment, mark the fumigated area to be sure the crop is planted into treated soil.

In addition to soil injection, you can now “chemigate” some fumigants into rows or strips with drip irrigation lines. Chemigation works best with fumigants that are formulated as “emulsifiable concentrates” (ECs). First, bury the irrigation lines below the rows or strips. Then inject the fumigant into the irrigation water as it flows through the drip lines. Chemigation systems must include special valves and drains to prevent back-flow contamination. Read the label information to find special use precautions for chemigation application equipment. Follow this information to the letter.

## Strip Fumigation

Use strip fumigation to treat blocks, rows or strips within nurseries, vineyards and orchards. Strip fumigation is a cross between broadcast and row fumigation. Like row fumigation, you

will treat only the area where the crop is to be planted. However, instead of “hilling-up” the soil into beds for planting, you will leave the treated area flat.

Strip fumigation varies depending on the type of fumigant(s) you use. To apply liquefied gases and volatile liquids via strip fumigation, it is usually best to inject them into the soil. As with broadcast treatments, these injections release the fumigant through one or more evenly spaced chisels. To apply moisture-activated fumigants via strip fumigation, spray or drop them onto the soil surface and then incorporate them by cultivation or irrigation. Seal the treated soil with heavy irrigation or compaction.

During strip fumigation, avoid extensive cultivation of the soil. Instead, leave the soil surface flat. This creates an area that is more suitable for planting trees. In orchards, fumigate 7- to 8-foot strips. Place the trees in the center of the strips. If the rows are 24 feet apart, only one-third of the area will actually be treated. This saves time and money. It also places a minimal amount of fumigant into the environment.

## Fumigating Individual Tree Sites

Sometimes, you will need to disrupt the soil structure to increase root growth and to diffuse the fumigant. This is often necessary when treating individual tree sites. First, dig a hole with a backhoe. Then, refill it using a small bulldozer. While it is being refilled, inject fumigant at a single point in the center, from the bottom of the hole. Seal the site according to the label directions. Plant a tree into the hole after the recommended exposure and aeration periods. Read the label for other product specifics.

You can use this procedure to treat single tree sites or entire orchards before planting. When treating single trees, be sure to confine treatment to an area no larger than 10 feet by

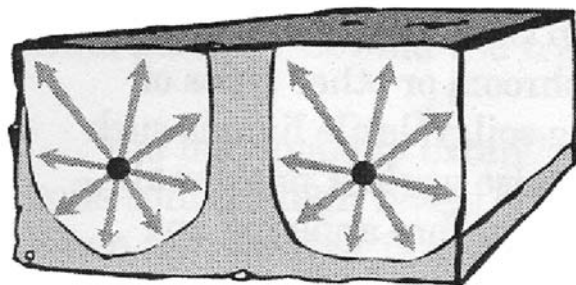

Broadcast fumigation

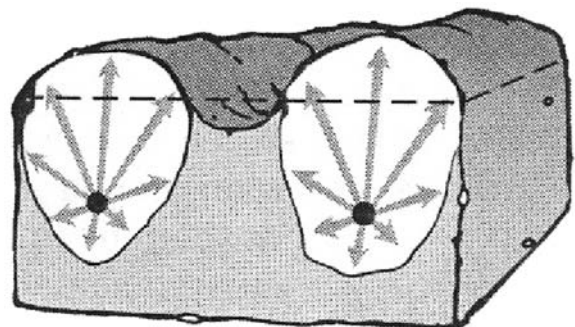

Row fumigation

10 feet. The center of the treated zone must be at least 5 feet from the dripline of the nearest existing tree. Otherwise, fumigant that diffuses through the soil can injure adjacent trees.

## Fumigating Seedbeds and Small Areas

Fall is the best time to fumigate seedbeds, plant nurseries and small fields. At this time, soil conditions, especially soil temperatures, are usually more favorable for soil fumigation than during other seasons. Before fumigating, check soil temperatures and moisture levels. Soil temperatures should be at least 55°F, and moisture levels should be sufficient for seeding. In addition, fumigants do not penetrate soil clods easily. Pests within such clods will often survive treatment. Before fumigating any soil, be sure it is pulverized, free of clods and smooth. If you treat soils in the fall, diseases and pest problems will not develop over winter. The soil will be ready to plant in the spring as soon as conditions become favorable.

Seedbeds and plant nurseries are usually treated with liquefied gases. However, you can also use moisture-activated fumigants. In most cases, you will use the broadcast method of application for liquefied gases. This is because the crop to be seeded may be spread over a large area rather than seeded in rows. Seal the treated area with tarps or plastic. To apply moisture-activated fumigants, spray or drop them onto the ground. Incorporate them into the soil by cultivation and/or irrigation. Then, seal the treated area with a tarp, heavy irrigation or compaction.

## Subsoil Fumigation

Some crops, such as many perennials, have deep, expansive root systems. To control nematodes where these plants are grown, you may need to inject fumigants at depths below those that can be reached with normal chisel equipment. Deep applications of soil fumigants often require “subsoil shanks.” These tools are identical to normal shanks, only longer. You also need to adjust fumigant rates to reflect the larger volume of soil being treated.

## Fumigating Greenhouse Soil and Mushroom Compost

Small amounts of greenhouse soil or mushroom compost can be fumigated to control certain pests. This type of fumigation is similar to tarpaulin fumigation for individual items.

Always choose an open or well-ventilated area for treatment. Good ventilation is essential during fumigation in greenhouses. Be aware that safety procedures for tarpaulin fumigation indoors are particularly stringent. For example, this application method usually requires two trained applicators to work together. You will also need to use gas detectors to measure fumigant levels during treatment and aeration.

Liquefied gases such as methyl bromide and methyl bromide plus chloropicrin mixtures work best for greenhouse fumigation. First, cover the soil with a polyethylene or plastic-coated nylon tarpaulin. Seal the edges tightly with soil, sand bags or other appropriate devices. Most fumigants for greenhouse soils require exposure periods of about 10 to 14 days. At the end of this period, release the fumigant by breaking the seal between the tarpaulin and the floor or ground. Wear a respirator, and be sure there is good ventilation around the area before beginning aeration. You can also treat soil or mushroom compost within specially designed fumigation chambers, if available. When treating mushroom or other types of compost and potting soil, volatile liquids such as chloropicrin may also work. Consider all environmental factors before applying any fumigant. Post warning signs and seal the area.

Fumigants will also control pests in planting flats filled with potting mix. First, arrange the flats in loose, crisscross stacks no more than five feet high. Then, cover and seal the stacks as described above. Introduce the fumigant at the top and in the center of the stack. Use one injection point for each 100 cubic feet. Aerate according to label directions.

## Soil Aeration

Soil aeration is the process of ensuring that most of the fumigant has left the treated soil. Aeration usually involves a waiting period between fumigation and planting. Although waiting periods for tarped soils in greenhouses can be as short as several days, those for fumigated field sites are usually 14 to 21 days. In many cases, you can speed the aeration process by tilling fumigated soils.

Aerate soils in one of two ways:

- Cultivate the soil to the depth of the treatment zone in order to release the fumigant.
- Delay planting or seeding to allow as much of the fumigant as possible to degrade in the soil or escape into the atmosphere.

If soils are tarped, you will need to remove the tarp at the end of the exposure period. Cultivation is often used to aerate soils when large areas are fumigated before planting. However, it is rarely used with tarpaulin methods on small areas such as outdoor seedbeds. Cultivation loosens the soil, increasing the size and continuity of the air spaces in soil. This creates a long, wide highway through which the fumigant can travel and leave the soil. When cultivating treated soil, avoid introducing untreated soil from below or beyond the treated zone.

You may need to extend aeration when soils contain high levels of organic matter or when the weather is cold and wet. Aeration is probably complete when you cannot detect the odor of the fumigant in or near the treated area. You can also perform a seed germination or transplant test to make sure that a fumigated area is safe for planting or seeding.

## Seed Germination Test

This test is often called the “lettuce seed test” or the “cress seed test.”

1. Use a small trowel or similar tool to collect several 2- to 4-ounce samples of treated and untreated soil. Sample any low, wet areas within the treated area.
2. Place each sample in an airtight jar (such as a glass canning jar). Moisten the surface of each sample and then sprinkle lettuce seed or cress seed on the soil. Close the lid tightly so that the jar is gastight.
3. Keep the samples in indirect sunlight at room temperature. Check the seed for germination after 1 to 3 days. If germination is similar between the samples of fumigated soil and untreated soil, the treated soil is safe for planting.

## Transplant Test

This test is often called the “tomato transplant test” or the “pansy transplant test.”

1. Transplant 5 to 10 seedlings (tomato, pansy, tobacco, etc.) into a fumigated area (particularly any heavy, wet areas) and into similar untreated soil nearby.
2. After several days, check the transplanted seedlings. Look for signs of wilting or damage to the roots. If you do not see any

noticeable differences between the plants in the fumigated area and those in the untreated soil, the fumigated soil is safe for planting.

3. Some suggest that to increase the sensitivity of the test, you can cover the plants with a 5-gallon bucket. Wait 24 hours. Then, uncover the plants. If they are dead, wait to seed or plant. The fumigant is still dissipating from the soil.

Proper aeration is important for your safety, the safety of your employees and clients and the health of future crops. Most soil fumigants can penetrate plant tissue and are toxic to many crops. If you do not aerate the soil correctly, residual fumigant may poison future crops. In general, seeded crops are less sensitive to fumigant residues in soil than are transplanted crops.

Aeration procedures vary for different:

- Fumigants
- Crops
- Environmental conditions

Every situation is different. Read the label for specific aeration information about each product that you use.

## Factors Affecting Soil Aeration

The rate of soil aeration is affected by several factors. The two most important are soil temperature and soil moisture.

### Soil Temperature

Soil fumigants diffuse through soil more quickly at higher soil temperatures, leading to faster aeration. This is because the molecules that make up soil fumigants have more energy to move more quickly at higher temperatures. Any fumigant sorbed by organic matter in soil should also desorb more quickly at higher temperatures. Extend aeration times when soil temperatures are low.

### Soil Moisture

Soil moisture is important in aeration because the films of water surrounding soil particles sorb much of the fumigant applied to soil. The fumigant within this water takes longer to diffuse through the soil and to degrade than does the fumigant in the soil air spaces.

Therefore, the more moisture in the soil, the longer it takes the fumigant to leave the soil.

Soil fumigants also vary in their volatility and in their ability to be absorbed into soil water. Fumigants that are less volatile and more water-soluble usually need longer waiting periods after fumigation than those that are more volatile and less water-soluble. In general, moisture-activated fumigants such as metam sodium may require longer waiting periods under cool, wet conditions than do volatile liquids such as chloropicrin or 1,3-dichloropropene. Liquefied gases such as methyl bromide are the least soluble in water and move most rapidly through the air spaces in soil.

## Aeration Procedures

Procedures for aeration vary with the fumigant, the crop, the specific application method used and environmental conditions. Read the label information for the aeration procedures most appropriate for the combination of these factors that you are dealing with. Follow the instructions exactly.

## Equipment Calibration

As with the application of any pesticide, equipment calibration is critical for soil fumigation. It will ensure that you apply the correct amount of fumigant to the target area.

There are many ways to calibrate soil fumigation equipment. Check with the equipment and fumigant manufacturer(s) to identify the specific settings and most appropriate procedures for the equipment and product(s) you plan to use. The specifics of calibration vary between different fumigants and types of equipment. This is especially true between soil injection and chemigation.

## Useful Information for Calibration

- 1 acre = 43,560 square feet (sq ft)
- 1 gallon (gal) = 4 quarts (qts) = 8 pints (pts) = 128 fluid ounces (fl oz)
- 1 gal = 3,785 milliliters (ml)
- 1 fl oz = 29.57
- 1 cubic foot of water = 7.481 gal
- 1 acre-inch of water = 27,156 gal
- 1 pound (lb) = 16 oz = 453.6 grams (gm)
- 1 mph = 88 feet per minute (ft per min) = 1.467 feet per second (ft per sec)

## Equipment Calibration – Soil Injection

You can use four basic methods to calibrate your soil injection equipment.

1. **Calibration by Volume.** This method directly measures the amount of material (volume) applied over a known area.
2. **Calibration by Weight.** This method uses the density and weight of a fumigant to estimate how much of the product is applied over a known area.
3. **Calibration by Time Using a Flowmeter.** The third method uses the flow rate of a fumigant and the time it takes to make the application to estimate how much product is applied.
4. **Calibration by Time Using Individual Outlets.** This method uses the volume of material applied to a known area and the time it takes to make the application to estimate how much fumigant is applied through each outlet of soil fumigation equipment.

All four methods require you to adjust the calibrated rate until it agrees with the label rate. If the equipment delivers too much material, it is overapplying. If it delivers too little material, it is underapplying. Adjust the equipment until it delivers the proper amount of material. Follow equipment manufacturer's instructions for changes. Adjustments may include altering pressure, application speed or orifice size.

Use the following equation to determine the amount of fumigant you should apply over the calibration test area:

$$\begin{array}{l} \text{Total amount (pounds} \\ \text{or gallons) of fumigant} \\ \text{that should be delivered} \end{array} = \frac{W \times L \times R}{43,560 \text{ sq ft per acre}}$$

- W = width (feet) of the test swath
- L = length (feet) of the test swath
- R = label rate (pounds or gallons) desired
- 43,560 = number of square feet in 1 acre

## Calibration by Volume

This method is the most direct way to measure the amount of fumigant applied. It requires safe and accurate measurement of fumigant. First, know the amount of fumigant in the

storage tank of your fumigation equipment. Then, apply the fumigant to a known, small area. Measure the amount of product remaining in the tank. The difference between the amount of fumigant that you started with and the amount that remains in the tank is what you actually applied. Repeat this process until the equipment delivers the amount required per acre.

**Example.** You want to calibrate a shank applicator that is applying a liquid fumigant. You will use 8 shanks to treat an effective swath width that is 8 feet wide. The test area is 1,400 feet long, so the test swath or calibration test area is 11,200 square feet (about a quarter of an acre). The label rate for the application is 20 gallons of fumigant per acre.

**Step 1:** Determine how much material the equipment should deliver from all of the shanks if the equipment is calibrated at 20 gallons per acre.

$$\begin{aligned} \text{Total gallons of} & \\ \text{fumigant that} & \\ \text{should be delivered} & = \frac{1,400 \text{ ft} \times 8 \text{ ft} \times 20 \text{ gal per acre}}{43,560 \text{ sq ft per acre}} \\ & = \quad \quad \quad \mathbf{5.14 \text{ gallons}} \end{aligned}$$

*NOTE: 5.14 gallons per 11,200 square feet = 20 gallons per acre.*

**Step 2:** Determine how much material your equipment is applying. Suppose that the tank on the fumigator holds 125 gallons. After fumigating your calibration test area, you measure 120 gallons.

$$\begin{aligned} \text{Total gallons your equipment is applying} & = \\ 125 \text{ gallons} - 120 \text{ gallons} & = \mathbf{5 \text{ gallons}} \end{aligned}$$

## Calibration by Weight

Many soil fumigants are now distributed in pressurized cylinders. If the fumigant is dispensed directly from the cylinder, you cannot collect the gas. In addition, many fumigant rates are expressed as weight (pounds) rather than volume (gallons). In these cases, preweigh the gas cylinder(s). Then, reweigh the cylinder(s) after fumigating your test area. Calculate how much was released.

**Example:** Again, you want to calibrate a shank applicator that is applying a liquid fumigant. You will use 8 shanks to treat an effective swath width that is 8 feet wide. The test area is 1,400 feet long, so the test swath or calibration test area is 11,200 square feet (about a quarter of an acre). The label rate for the application is 20 gallons of fumigant per acre.

**Step 1:** Determine how much material the equipment should deliver from all of the shanks if the equipment is calibrated at 20 gallons per acre. You know from the product label that the weight of the fumigant to be applied is 10.2 pounds per gallon.

Total pounds of product that should be delivered per acre:

$$10.2 \text{ lbs per gal} \times 20 \text{ gal per acre} = \mathbf{204 \text{ lbs per acre}}$$

$$\begin{aligned} \text{Total pounds of} & \\ \text{fumigant that should} & \\ \text{be delivered in the} & \\ \text{test area} & = \frac{1,400 \text{ ft} \times 8 \text{ ft} \times 20 \text{ gal per acre}}{43,560 \text{ sq ft per acre}} \end{aligned}$$

$$\begin{aligned} \text{Target amount to be} & \\ \text{applied in test area} & = \quad \quad \quad \mathbf{52.45 \text{ lbs of product}} \end{aligned}$$

*NOTE: Target amount to be applied is 52.45 pounds per 11,200 square feet = 204 pounds per acre.*

**Step 2:** Determine how much material your equipment is applying. Suppose that the cylinder on the fumigator weighs 200 pounds. After fumigating your calibration test area, it weighs 150 pounds.

Total pounds of actual product your equipment is applying:

$$200 \text{ lbs} - 150 \text{ lbs} = \mathbf{50 \text{ lbs}} \text{ per } 11,200 \text{ sq ft}$$

## Calibration by Time Using a Flowmeter

Flowmeters are another tool to control the volume of soil fumigant that you are applying. A flowmeter measures the flow rate (the volume of fumigant that passes through your equipment per unit time). Although flow rate is usually calculated in gallons per minute, most flowmeters indicate flow rate as a percentage of their maximum output (% flow rate). To calibrate fumigation equipment with a flowmeter: first, time an application over a test area. Then, adjust the in-line valve to tune the flow rate through your flowmeter, or adjust your travel speed to deliver the desired amount of soil fumigant.

**Example.** You want to calibrate a fumigator equipped with a flowmeter. The label rate for the application is 20 gallons of fumigant per acre.

**Step 1:** Determine the time needed to treat an acre. First, measure your application speed in seconds or an increment of time. The fumigator treats an effective swath width that is 8 feet wide. Mark the start and finish of a 100-foot test course. Time the equipment over the course, once in each direction. Be sure to conduct the speed test in the application area with the equipment loaded and the shanks at application depth. In this case, your times were: 16 seconds and 18 seconds.

$$\begin{aligned} \text{Average time it takes your} & \\ \text{equipment to travel 100 feet} & = \frac{16 \text{ sec} + 18 \text{ sec}}{2} \\ \text{(and treat 800 square feet)} & \\ \text{Average time} & = \mathbf{17 \text{ sec}} \\ \text{Time to fumigate a square foot} & = \frac{17 \text{ seconds}}{800 \text{ square feet}} \\ \text{Time to fumigate a square foot} & = 0.02125 \text{ seconds} \\ \text{Convert time per square} & \\ \text{feet to time per 1 acre} & = \frac{0.02125 \text{ sec per sq ft} \times 43,560 \text{ sq ft per acre}}{43,560 \text{ sq ft per acre}} \\ \text{Time to cover 1 acre} & = \mathbf{925.65 \text{ seconds per acre}} \end{aligned}$$

$$\begin{aligned} \text{Convert seconds per acre} & \\ \text{to minutes per acre} & = \frac{925.65 \text{ seconds per acre}}{60 \text{ seconds per minute}} \\ \text{Time to cover 1 acre in} & \\ \text{minutes} & = \mathbf{15.43 \text{ minutes per acre}} \end{aligned}$$

Calculate the time it takes to fumigate each square foot of soil:

$$\begin{aligned} \text{Total gallons per acre you} & \\ \text{would apply at 100\% flow rate} & = \frac{15.43 \text{ min per acre} \times 1.80 \text{ gal per min}}{1.80 \text{ gal per min}} \end{aligned}$$

$$\text{Gallons per acre at 100\% flow} = \mathbf{27.78 \text{ gal per acre}}$$

$$\begin{aligned} \text{Percent flow rate you} & \\ \text{should use to achieve} & \\ \text{the label rate} & = \frac{20 \text{ gal per acre}}{27.78 \text{ gal per acre}} \times 100 \end{aligned}$$

$$\begin{aligned} \text{Percent flow rate to} & \\ \text{use for label rate} & = \mathbf{71.99 \text{ or } 72\%} \end{aligned}$$

**Step 2:** Determine the flowmeter setting needed to deliver the desired rate of fumigant per acre. The flowmeter that you are using is calibrated specifically for the product that you are applying. The maximum flow rate (100 percent) setting of the meter is 1.80 gallons per minute.

So, you should set the flowmeter at 72 percent in order to deliver the label rate of the fumigant.

**Step 3 (if necessary):** Although some flowmeters are pre-calibrated for specific fumigants, **many are calibrated for water**. Because soil fumigants are more dense than water, they move through flowmeters more slowly than water. Therefore, when using a flowmeter that has been calibrated for water, you must use correction factors to calculate the correct volume of fumigant applied.

$$\text{Correction Factor} = \frac{1}{\text{SQUARE ROOT of specific gravity of the fumigant}}$$

Specific gravities are often listed in the chemical and physical properties section of a

products material safety data sheet (MSDS). See Table 3-1 of Unit 3 for a list of the specific gravities of several fumigants discussed in this manual. These values were accurate at the time this manual was printed. However, the specific gravity of a fumigant may change periodically if the manufacturer makes a small change in the product's formulation.

For the example above, calculate the CF if the flowmeter is calibrated for water. The specific gravity of the fumigant you are applying is 1.218.

$$\begin{aligned} \text{Correction Factor} & = \frac{1}{\text{SQUARE ROOT of } 1.218} \\ \text{Correction Factor(CF)} & = \mathbf{0.906} \end{aligned}$$

Then, use the CF to adjust the flow rate for water to that for the product you are using.

$$\begin{aligned} \text{Percent flow rate you} & \\ \text{should use to achieve} & \\ \text{the label rate of soil} & \\ \text{fumigant} & = \frac{\text{percent flow rate for water}}{\text{CF}} \end{aligned}$$

$$= \frac{71.99\%}{0.906}$$

$$\begin{aligned} \text{Percent flow rate to use} & \\ \text{to achieve the label} & \\ \text{rate of soil fumigant} & = \mathbf{79.46 \text{ to } 80\%} \end{aligned}$$

So, the **flowmeter should be set at 80 percent** to deliver the label rate of the fumigant.

## Calibration by Time Using Individual Outlets

When using fumigation equipment that delivers product through more than one outlet (usually a shank), be sure that each outlet delivers a volume of fumigant that is within 10 percent of the other outlets. Otherwise, your treatment may not be uniform. To check the uniformity of your equipment, you must measure the output from each outlet.

*NOTE: For safety reasons, water or diesel fuel can often be collected instead of fumigant.*

**Example.** You want to use water to check the output from a fumigation rig with 8 shanks. The rig treats a swath 8 feet wide, and you have marked out a test area 100 feet long. The label rate for the product you will use is 20 gallons per acre.

**Step 1:** Determine how much fumigant each shank should deliver.

$$\begin{array}{l} \text{Total gallons of} \\ \text{fumigant that should} \\ \text{be delivered by all} \\ \text{8 shanks} \end{array} = \frac{100 \text{ ft} \times 8 \text{ ft} \times 20 \text{ gal. per acre}}{43,560 \text{ sq ft per acre}}$$

$$\begin{array}{l} \text{Gallons per} \\ \text{8 shanks} \end{array} = \quad \mathbf{0.367 \text{ gal. of product}}$$

Convert to fluid ounces per shank:

$$\begin{array}{l} \text{Convert output to fluid} \\ \text{ounces} \end{array} = 0.367 \text{ gal} \times 128 \text{ fl oz per gal}$$

$$\begin{array}{l} \text{Ounces delivered by} \\ \text{8 shanks per 100 feet} \end{array} = \quad 47 \text{ fluid ounces}$$

$$\begin{array}{l} \text{Ounces per shank} \end{array} = \frac{47}{8}$$

$$\begin{array}{l} \text{Ounces per shank} \end{array} \quad \mathbf{5.9 \text{ fluid ounces}}$$

**Step 2:** Determine how long it takes your equipment to travel over the test area. Time the equipment over the test course, once in each direction. Conduct the speed test in the application area with the equipment loaded and the shanks at application depth. In this case, your times were: 16 seconds and 18 seconds.

$$\begin{array}{l} \text{Average time it takes} \\ \text{your equipment travel} \\ \text{over the test area} \end{array} = \frac{16 \text{ sec} + 18 \text{ sec}}{2}$$

$$\begin{array}{l} \text{Average time to travel} \\ \text{100 feet} \end{array} = \quad \mathbf{17 \text{ sec}}$$

**Step 3:** Measure the output from each shank over the same time that it took for you to travel over the test area. If you use water for these measurements, you must use a correction factor to convert your measured output from ounces of water to ounces of fumigant. The correction factor is calculated based on the specific gravity of the fumigant. If the specific gravity of your fumigant is 1.218, you can calculate the correction factor as:

$$\begin{array}{l} \text{Correction Factor} \end{array} = \frac{1}{\text{Square root of specific gravity of fumigant}}$$

$$= \frac{1}{\text{Square root of 1.218}}$$

$$= \frac{1}{1.104}$$

$$\text{Correction Factor (CF)} = \quad \mathbf{0.906}$$

Then, use this CF to calculate how much water to expect from each outlet. In this example, you would collect water from each shank for 17 seconds (the length of time that it took your fumigator to travel over the test area). Calculate the volume of water per shank that is equivalent to the 5.9 ounces of fumigant that you need to apply.

$$\begin{array}{l} \text{Fluid ounces per} \\ \text{shank of water} \end{array} = \frac{\text{Desired fluid ounces of fumigant per shank}}{\text{CF}}$$

$$= \frac{5.9 \text{ fluid ounces fumigant per shank}}{0.906}$$

$$\begin{array}{l} \text{Fluid ounces per} \\ \text{shank of water to} \\ \text{collect} \end{array} = \quad \mathbf{6.5 \text{ fluid ounces water per shank to achieve desired flow of fumigant}}$$

## Equipment Calibration – Chemigation

Applying fumigant through irrigation requires great attention to calibration and operation details. Failure to calibrate accurately or to monitor the system continuously during the application can lead to costly mistakes. It may also result in poor control or illegal overrate applications.

Check your sprinkler system for proper operation and uniform water distribution. Determine the length of time necessary for the irrigation system to apply approximately 1 acre-inch of water. Catch cups can be used to do this.

**Example.** You want to chemigate a 2-acre outdoor seedbed. The label rate for the product you plan to use is 75 gallons per acre.

**Step 1:** Calculate the total amount of product that you want to apply.

$$\begin{array}{l} \text{Total amount of product} \\ \text{you want to apply} \end{array} = \frac{75 \text{ gal per acre} \times 2 \text{ acres}}{2 \text{ acres}}$$

$$\begin{array}{l} \text{Desired amount of product} \\ \text{per 2 acres} \end{array} = \quad \mathbf{150 \text{ gal}}$$

**Step 2:** Determine the length of time that your chemigation will take. This is based on how much water you intend to apply and the characteristics of your irrigation system. For this example, you want to apply the product in 1 acre-inch of irrigation water. Your sprinkler system is set to apply 1 acre-inch over a 4-hour period.



**Step 3:** Calculate the injection rate needed to apply the proper amount of fumigant:

$$\begin{aligned} \text{Injection rate needed} &= \frac{150 \text{ gal}}{4 \text{ hrs}} \\ &= 37.5 \text{ gal per hr} \\ \text{Convert to fluid ounces per hour} &= 37.5 \text{ gal per hr} \times 128 \text{ fl oz per gal} \\ &= \mathbf{4,800 \text{ fl oz per gal}} \end{aligned}$$

Convert fluid ounces per hour to fluid ounces per minute.

$$\begin{aligned} \text{Convert to fluid ounces per minute} &= \frac{4,800 \text{ fl oz per hr}}{60 \text{ min per hr}} \\ \mathbf{\text{fluid ounces per minute}} &= \mathbf{80 \text{ fl oz per min}} \end{aligned}$$

Once the timer is set to deliver 1 acre-inch of water, do not reset it before making the application. If the timer is reset for any reason, recalibrate the system to ensure an accurate level of water delivery.

Check the injection pump and nurse tank system to ensure proper operation. Clean all screens and filters. Make sure check valves are in place between the injector pump and both the water source and the nurse tank.

## Test Your Knowledge

**Q. Describe how soil fumigants work.**

- A. Soil fumigants move through soil by diffusing through the air spaces between soil particles. Soil insects moving through air spaces are then killed by the fumigants. As fumigants move through soil air space, they also dissolve into the film of water that surrounds soil particles. Nematodes and pathogens living in these films of water are killed by the fumigant that dissolves into the soil water. Weed seeds die after absorbing soil water that contains a soil fumigant.

**Q. Name and describe the three types of fumigants most commonly used in soil fumigation.**

- A. 1. Liquefied gases – Fumigants that must be kept under pressure in order to remain a liquid. They change from liquid to gas when released from their pressurized containers.
2. Volatile liquids – Fumigants that exist as liquids under atmospheric pressure but evaporate under normal temperatures.
3. Moisture-activated fumigants – Fumigants that require moisture to release gas. For soil applications, this type of fumigant is formulated as a liquid or as micro-granules or powder.

**Q. Describe three ways you can seal soil during and/or after fumigation.**

- A. 1. Cover the soil with a tarpaulin.
2. Compact the soil at the point(s) of injection. By reducing and removing air spaces in the soil, the soil itself will prevent from escaping.
3. Flood the area using irrigation. This will increase the amount of fumigant that remains in the soil and decrease the amount that escapes to the atmosphere before it kills the target pest.
4. “Hill-up” enough soil above the point where a fumigant is injected or released. In bed treatments, this is usually about 16 inches.

**Q. What method of fumigation is the most economical for crop fields? Why?**

- A. Row treatment because you are applying chemical only to the portions or rows of a field that will be planted.

**Q. Discuss the pros and cons of broadcast treatment.**

- A. Broadcast treatments allow producers to fumigate whole fields. This may be necessary if it is not practical to fumigate only a portion of a field or when you must reduce populations of the target pest throughout a field. Broadcast fumigation also enables a producer to cultivate a treated field without worrying about contaminating the treated area with untreated soil. Using closely spaced chisels or shanks ensures that the amount of soil treated from each point of injection overlaps and that all of the soil above the point of injection is fumigated. Unfortunately, broadcast treatments are usually expensive. They also release a lot of chemical into the environment.

**Q. What is strip fumigation? How is it mostly used?**

- A. Strip fumigation is a cross between broadcast and row fumigation. It is useful in treating blocks, rows or strips within nurseries, vineyards and orchards. Strip fumigation often saves time and money and places a minimal amount of fumigant into the environment.

**Q. Describe how you would fumigate an area where you plan to plant a single tree.**

- A. First, dig a hole with a backhoe. Then, refill it using a small bulldozer. While it is being refilled, inject fumigant at a single point in the center, from the bottom of the hole. Seal the site according to label directions. Plant a tree into the hole after the recommended exposure and aeration periods. Read the label for other product specifics. Be sure to confine treatment to an area no larger than 10 feet by 10 feet. The center of the treated zone must be at least 5 feet from the dripline of the nearest existing tree.



**Step 4:** Determine how much water you should collect per shank that is equivalent to the amount of fumigant you want to apply. Assume the specific gravity of the product you are using is 1.218.

$$\begin{aligned} \text{Correction Factor} &= \frac{1}{\text{Square root of } 1.218} \\ &= \mathbf{0.906} \end{aligned}$$

$$\begin{aligned} \text{Fluid ounces of water} &= \frac{5.88 \text{ fl oz of fumigant}}{\text{per shank}} \\ \text{per shank} &= \frac{\quad}{0.906} \\ &= 6.49 \text{ fl oz of water per shank} \end{aligned}$$

**Q. The broadcast rate for a liquefied gas is 400 pounds per acre. The effective swath width of your fumigation equipment is 10 feet, and your calibration test area is 66 feet long. How many pounds of fumigant should be delivered to the test area to achieve the 400 pounds per acre rate?**

$$\begin{aligned} \text{A. Total lbs that} & \\ \text{should be} & \\ \text{delivered} &= \frac{66 \text{ ft} \times 10 \text{ ft} \times 400 \text{ lbs per acre}}{43,560 \text{ sq ft per acre}} \\ &= 6 \text{ lbs} \end{aligned}$$

# Unit 6. Public, Personal and Environmental Safety

## Learning Objectives

After studying this unit, the learner will be able to:

- Understand the risks fumigation poses to people and the environment.
- Practice safe fumigation procedures that reduce or eliminate personal risk and risk to the public.
- Select appropriate tools and equipment to make fumigation safer and more effective.
- Use safety checklists before, during and after a fumigation operation.
- Recognize the signs and symptoms of fumigant exposure.
- Administer basic first aid in the event of fumigant exposure.

The Arkansas Core Manual, **Applying Pesticides Correctly**, is a comprehensive guide to pesticide safety. The Core Manual discusses basic safety considerations for all applicators.

This unit covers safety practices specific to raw commodity, structures and soil fumigation. By reading it, you will learn how to reduce or eliminate fumigant exposure to yourself and to the public. It will teach you about personal protective equipment (PPE), warning gases and exposure limits. You will discover the importance of posting warning signs and writing an application plan. At the end of this unit are several safety checklists. This unit will explain why it is critical to use these checklists before, during and after every fumigation.

## Terms to Know

**Aerate** – To replace fumigant-containing air or water with fresh air and/or water that contains little or no fumigant. Aeration must follow all fumigation operations.

**Antidote** – A remedy that may counteract the effects of a pesticide.

**Exposure** – When a person or organism comes in contact with a pesticide by inhalation, ingestion, skin contact or any other method.

**Overexposure** – When a person or organism comes in contact with enough pesticide to cause harm.

**Material Safety Data Sheet (MSDS)** – A printed report that details information on the fumigant manufacturer, identity of hazardous ingredients, physical and chemical characteristics, fire and explosion hazard data, reactivity data, precautions for safe handling and use and control measures.

**Permissible Exposure Limit (PEL)** – An OSHA standard that designates the maximum exposure permitted as an 8-hour time-weighted average (TWA).

**Personal Protective Equipment (PPE)** – Clothing or devices used to protect the human body from exposure to pesticides and pesticide residues.

**Rinsate** – A pesticide-containing water (or other liquid) that results from rinsing a pesticide container, pesticide equipment or other pesticide-containing materials.

**Threshold Limit Value-Short Term Exposure Limit (TLV-STEL)** – The concentration of fumigant to which most workers can be exposed continuously for a short period without suffering from:

- Irritation
- Chronic or irreversible tissue damage
- Narcosis (drunkenness) that may increase the chance of accident or injury

Exposures to concentrations at the STEL should not be longer than 15 minutes and should not occur more than four times per day. The STEL is expressed in parts per million (ppm) or milligrams per cubic meter (mg/m<sup>3</sup>).

**Threshold Limit Value-Time Weighted Average (TLV-TWA)** – The average concentration of fumigant to which most workers may be repeatedly exposed 8 hours a day, 40 hours a week without adverse effect. The TLV-TWA is expressed in parts per million (ppm) or milligrams per cubic meter (mg/m<sup>3</sup>).

**Volatility** – The ability of a substance to turn into a gas (vapor) at relatively low temperatures.

**Warning Gas** – A chemical that can be added to an odorless fumigant to help workers detect the product. Warning gases give off strong smells or have an irritating effect.

Fumigants are the most hazardous of all pesticides. They are highly volatile, penetrating and poisonous. Even experienced fumigators can cause injuries or damage because of these hazards:

- Fumigants can kill humans.
- Fumigants can kill rodents, bats, birds, pets and other animals that are on site during treatment.
- Fumigants can cause severe burns and damage internal organs.
- Fumigants can cause fires and explosions.
- Improper fumigant use can result in illegal residues in/on foods.
- Some fumigants can inhibit the germination of seeds.
- Some fumigants can corrode metals.
- Some fumigants react with certain materials to produce bad odors and flavors.
- Most fumigants can kill plants.

Three agencies regulate the use of fumigant pesticides – the Environmental Protection Agency (EPA), the Arkansas State Plant Board (ASPB) and the Occupational Safety and Health Administration (OSHA). Each agency administers regulations that concern pesticide handling.

You must follow all directives issued by the EPA, ASPB and OSHA, and the instructions in the fumigant label information. These agencies may fine you for misusing a fumigant or for failing to properly use and maintain your protective equipment.

This unit discusses safety issues, general precautions and emergency procedures related to fumigation. It will describe how to protect the public, your coworkers and yourself from exposure. It will also provide safety checklists for all stages of fumigation. However, no publication can cover all situations for all products. Follow the instructions in the label information specific to each product that you use. Remember that there is no substitute for good common sense.

Unit 7 will cover safety equipment and its proper use.

## Protecting the Public and the Environment

Fumigants are some of the most toxic pesticides available. Their safe use and handling requires skill and care. This manual discusses fumigants that control pests in structures, stored products, raw commodities and soil. Some commodities are edible-corn, wheat, rye, etc. Others are stored where people work and animals live, grain bins, silos, etc. Agricultural fields supply us with fruits, vegetables and animal feed. These fields may be located near homes, livestock facilities or water sources. In nearly all cases, fumigants control pests on items or in areas with which people and animals have direct contact. Your ability to apply fumigants safely is critical. You must protect the public and the environment from exposure.

There are several important ways to protect others from fumigant exposure. These include:

- Reading and following the label directions
- Posting warning signs
- Monitoring for the fumigant
- safely transporting, storing and disposing of fumigants and their containers
- Following tolerance levels, properly aerating the treatment area
- Preparing and planning well before application

## Read the Label Information

The most important thing you can do to ensure personal and public safety is to read the label. Fumigant labels include both an abbreviated sticker label and an extended label, often in booklet form. Treat these two documents as you would any pesticide label. Follow their instructions to the letter. It is the law. This manual refers to the sticker label and the label booklet together as “label information.”

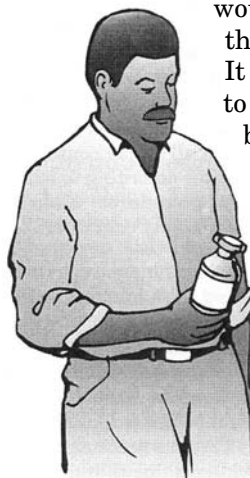

The label information will tell you how and where to use the product. It will give you detailed application and aeration instructions. You will discover how to store the chemical properly. The label information may

note specific sites that you should avoid or application methods that are not permitted. It will also describe specific safety precautions. Read all of the label information completely before using any fumigant for any purpose.

## Signage for Fumigated Areas

Warning signs or “placards” protect the public during and after fumigation. They are also posted during transportation and storage of a fumigant. A warning sign provides a barrier between people and the fumigated site or item. Federal and state laws require you to post warning signs at all accesses leading to areas or commodities under fumigation. Only authorized fumigators wearing the proper personal protective equipment (PPE) may enter treated areas before and during aeration.

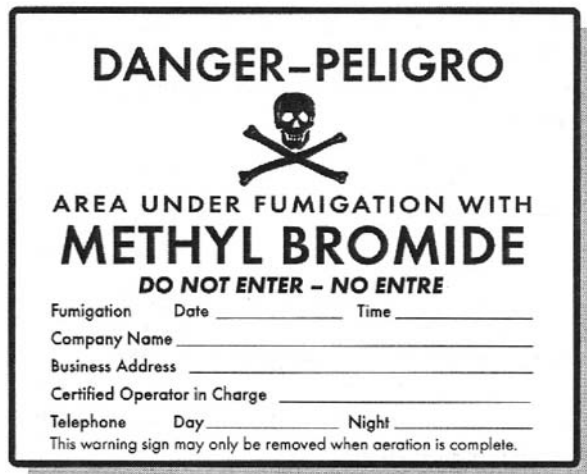

Follow label directions regarding posting warning signs before and during fumigation. Most fumigant labels have specific directions regarding signage:

- What the sign should say
- How many signs to use
- Where to post the signs
- How long to leave the signs in place

Posting warning signs will help to keep unauthorized persons away. Do not remove the signs until the treated equipment and surrounding area have been completely aerated.

## Monitoring for the Fumigant

There is always a risk that fumigant gas will escape from a treatment area. Monitoring for these leaks is critical. When treating

commodities that are next to work areas, be sure to take air samples during treatment. Use appropriate gas detectors to verify that fumigants are not leaking. This is particularly important during indoor treatments. See Unit 7 for more information about gas detectors.

## Transporting Fumigants

Transporting a fumigant is dangerous. Leaks and spills caused by accidents are sometimes beyond your control. However, by taking the following precautions and using common sense, you can prevent many accidents.

- Do not use public transportation (subways, buses, trains or taxis) to transport fumigants.
- Do not transport fumigants through tunnels unless you get permission from the Arkansas Department of Transportation (ADOT).
- Do not transport fumigants and people together in a closed vehicle.
- Be sure you have the required driver’s license with any appropriate endorsements for the specific fumigant you plan to transport.
- Read the label information and/or the Material Safety Data Sheet (MSDS) to determine the signage requirements for transporting each fumigant that you use. You can also contact the fumigant manufacturer for more information on placarding for transportation.
- Be sure cylinders are upright and secured during transport.
- Mount cylinders so they are protected from rear end collision.
- Do not remove protective valve covers until just before use.

*NOTE: It is illegal to transport goods over public roads or highways if those goods are undergoing fumigation or have not been completely aerated.*

Always follow federal and state department of transportation regulations when transporting fumigants and/or their containers. Contact your local Arkansas Department of Transportation office for further information.

## Storage and Disposal of Fumigants

Storage of fumigants is hazardous. Whenever possible, buy them just before you need them to shorten the storage period. Store all fumigants on sturdy shelves in an area apart from feed or seed. A separate building that is well ventilated or has a mechanical exhaust system is best. Be sure that all fumigant storage areas are locked and posted as pesticide storages. Warning signs should indicate the presence of fumigants.

Fumigants can escape from faulty valves or damaged or corroded cans. Leaks can cause dangerous concentrations to build up in closed storerooms. Check valves and containers regularly for leaks. Before entering any storage area, run an exhaust fan to remove vapors that may have built up inside.

Do not risk contamination of water supplies. Dispose of all empty containers, residues and rinsates according to state waste management procedures. Keep all pesticides and their empty containers out of the reach of children.

## Tolerance Levels

Fumigants should not change or impair treated material in any way. Nor should they leave any residues on raw agricultural products that could be hazardous during processing. The EPA has determined the amount of pesticide residue that may safely remain in or on agricultural products. This is called the “tolerance level.” Be sure fumigant residues never exceed these levels by following label directions to the letter. Consult the label information or the registrant for tolerance levels specific to the product(s) you use and commodity(ies) you treat. Tolerance levels come from the Code of Federal Regulations.

## Proper Aeration

Proper aeration is important for your safety, the safety of your crew and the safety of your clients. Poor aeration is one of the most common problems associated with fumigation. Read and follow the instructions in the label information exactly. When treating raw agricultural products, be sure the rate of air exchange during the aeration phase will adequately remove the

fumigant. If necessary, use fans or other ventilation equipment. Also, check air temperatures. The treatment area should be warm enough to allow the fumigant to completely desorb from the treated agricultural product. Heat the area or increase the aeration time if necessary. Finally, check the sorptive capacity of the commodity you are treating. Highly sorptive materials require longer aeration periods. Adjust your aeration time as needed. See Unit 5 and Unit 8 for more information on aeration procedures.

## Preparation and Planning

Preventing public and environmental exposure also relies on how well you prepare. How well have you sealed an area? Have you inspected all equipment thoroughly? Are you applying the fumigant at or below the label rate? Have you set aside enough time to completely aerate the site or item? Have you set up fences and posted warning signs to keep people, livestock and pets out of the treatment area? Details about proper application methods are described in Unit 5 and Unit 8. Use this information to develop a solid application plan. Review your plan several times. Then use the checklists at the end of this unit to be sure nothing has been overlooked. Appendix A contains safety checklists that you can copy and use.

Remember, you, the applicator, are the most important variable in fumigation. Your education and training will directly affect the safety and success of your operation.

## Personal Safety

Safety is always a concern for you as a fumigant applicator. You must consider your own safety, as well as that of your coworkers, your clients and the people who will use the areas you treat.

Human safety is addressed throughout the Arkansas Core Manual, Applying Pesticides Correctly. Unit 7 (Harmful Effects and Emergency Response) and Unit 8 (Personal Protective Equipment) are devoted to human health and safety issues. Unit 7 describes the signs and symptoms of pesticide injury or illness. It also tells you how to respond to a poisoning emergency. Unit 8 discusses how to select, use and care for protective clothing and equipment. Review these sections of the Core Manual for basic pesticide safety information.



Besides taking the precautions outlined in the Arkansas Core Manual, you must also consider the specific risks associated with fumigants.

## Always Work in Pairs

One of the most important things you can do to protect yourself during fumigation is to **always work with another person** when applying fumigants. This person can assist you immediately if you become injured or incapacitated while working around these products. In fact, many fumigant labels require fumigators to work in pairs during application or gas monitoring.

## Routes of Exposure

As a fumigant applicator, you may be exposed to fumigants in several ways. Fumigants can enter your body through your lungs (inhalation), your eyes (ocular exposure), your mouth (ingestion) and even your skin (dermal exposure). The most dangerous and common type of fumigant exposure is inhalation. Most fumigants are highly toxic. Breathing even small amounts of some fumigants can cause serious illness or death. To protect yourself, read the label information. Find out what personal protective equipment (PPE) the manufacturer requires. Then, learn what to do in case of exposure. See “First Aid for Fumigant Poisoning” later in this unit for details about how to handle different types of fumigant exposure.

## PPE

Personal protective equipment (PPE) is the name given to clothing and devices that minimize your exposure to pesticides. The label information for each product lists the minimum PPE required for using that pesticide. Federal and state laws require pesticide users to follow all instructions on the product label, including wearing the appropriate PPE.

Respiratory protection is the most important piece of PPE for fumigators. When you are surrounded by toxic gas, respirators provide you with clean air to breathe or filter the contaminated air. There are several types of respirators. Each one has its pros and cons. Respirators must be “fit-tested” to each user to ensure that they are sized correctly and will work properly. Users must also pass the appropriate physical tests to ensure that they can wear and use a



Respiratory equipment

respirator safely. Read the label information to determine which type of respirator you will need. If you have questions about respirators, contact your county Extension agent. See Unit 7 to learn more about the selection, use and maintenance of respirators.

Fumigation also requires other types of PPE. These include protective clothing and gloves. Requirements vary with the fumigant. Read the label information carefully.

To protect your skin, some fumigants recommend that you wear loose-fitting clothes, long-sleeved shirts, long pants and socks. Other products say nothing about clothing.

The need for gloves also varies. For example, some solid fumigants require fumigators to wear gloves because of possible skin irritation. Read the label information to be sure you use the right kind of glove. Other fumigants, particularly liquid products, do not require gloves. Some may even prohibit you from wearing gloves.

Read the label information to learn which items are required for the product(s) you plan to use.

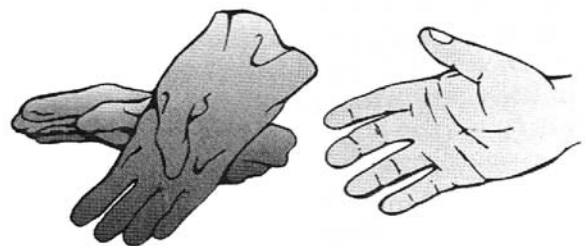

Some fumigants require you to wear gloves during fumigation. Others do not.

## Other Tools for Personal Safety

Because inhalation exposure poses the greatest risk during fumigation, several tools are available to reduce or prevent this type of exposure. These include:

- Warning gases
- Exposure limits
- Gas detectors

*NOTE: The safe and effective use of gas detectors is covered in Unit 7.*

## Warning Gases

It is often helpful to add warning chemicals to odorless fumigants. These products give off an odor that can help you detect the presence of harmful gas. However, you should never rely on warning gases alone. Keep the following facts in mind:

- Individuals vary in their ability to detect and quantify odors.
- Odors only indicate whether the fumigant is present. They do NOT tell you the concentration of the fumigant.
- You may suffer olfactory fatigue. Over time, you may lose the ability to smell a particular warning agent.

Warning gases serve a useful purpose, but they are not foolproof. Use them as one of many safety tools.

## Exposure Limits

You can also reduce your risk of inhalation overexposure by monitoring fumigant concentrations during treatment and aeration. Be sure your exposure stays below established exposure limits such as the TWA, STEL and PEL.

An exposure limit is the highest level of fumigant that you may be exposed to without being required to use any controls to reduce your exposure. The American Conference of Governmental Industrial Hygienists (ACGIH), OSHA and the National Institute of Safety and Health (NIOSH) are all agencies that establish these limits. Each agency uses different terms to refer to long- and short-term exposure limits. Refer to the fumigant label information to find out what the different exposure limits are for each product you use.

The three most common terms used to express the exposure limit of a fumigant are the:

- Threshold limit value-time weighted average (TLV-TWA)
- Threshold limit value-short term exposure limit (TLV-STEL)
- The permissible exposure limit (PEL)

TLV-TWA or “TWA” is an ACGIH term that refers to the average concentration of a fumigant to which most workers may be repeatedly exposed 8 hours a day, 40 hours a week without adverse effects. Concentrations at or below the TWA represent conditions that you may be exposed to on a daily basis. These levels are considered safe. Concentrations above the TWA may lead to “overexposure” to a fumigant. This can cause discomfort, sickness or even death. These levels are considered unsafe. The TWA is usually expressed in parts per million (ppm) or milligrams per cubic meter (mg/m<sup>3</sup>).

By monitoring fumigant levels throughout treatment and keeping your exposure level below the TWA, you can prevent injury and illness caused by overexposure. However, people’s susceptibility and response to fumigants varies widely. For example, a small number of workers may experience discomfort or minor irritation from fumigant concentrations at or below the TWA. Others may suffer more serious health effects – even death – due to a preexisting condition. Even when the TWA is low, observe yourself and your coworkers for any signs or symptoms of exposure.

For short-term exposure, look for the TLV-STEL on the product label. Like the TLV-TWA, this ACGIH term is often shortened to “STEL.” Specifically, STEL is the concentration of fumigant to which most workers can be exposed continuously for a short period without suffering from:

- Irritation
- Chronic or irreversible tissue damage
- Narcosis (drunkenness) that may increase the chance of accident or injury

Exposure to concentrations at the STEL should not be longer than 15 minutes and should not occur more than four times per day. The STEL is expressed in ppm or mg/m<sup>3</sup>.

PEL is an OSHA standard that designates the maximum exposure permitted as an 8-hour TWA. OSHA sets PELs to protect workers against the health effects of exposure to fumigants.

Usually, OSHA PELs are not as conservative as are ACGIH TLVs. With this in mind, it is

always wise to comply with the most stringent exposure limit. This will ensure the highest degree of safety and health. In the absence of any exposure limits, you should always strive to minimize your exposure.

## Safety Checklists

Keep safety foremost in your mind when planning any fumigation operation. Focus on protecting lives and preventing fires. Plan ahead, especially when working in a remote location. Know how to get help if something goes wrong.

The following checklists will help you organize the many aspects of fumigation.

This information is general. It does not apply to all fumigants in all situations. Always read the label information first. Become familiar with the dangers of the product(s) you intend to use. Some manufacturers provide checklists specific to their products. Use these lists as well.

### Safety Checklists – Raw Agricultural Product Fumigation

#### Preliminary Planning

*(Appendix A contains a version of this checklist that you can photocopy and use.)*

- ✓ Draw or locate a sketch of the structure you plan to fumigate. Indicate the layout of the structure, connecting structures and escape routes above and below ground.
- ✓ Seal all spouts, conveyors, conduits, heating ducts, pipes, cracks, crevices, broken windows and other possible openings leading from the areas that you plan to treat.
- ✓ Record the number and names of everyone who routinely enters the area. Note the proximity of other nearby people and animals. Keep children, unauthorized persons and pets away from the application site.
- ✓ If you plan to treat a commodity, learn about it. Find out its mode of storage and its condition. If possible, get a previous treatment history.
- ✓ If you plan to treat a commodity within a structure, learn about the structure. What does it consist of: wood, brick, concrete? Note the locations of doors, windows and dividing walls. Check airflow patterns.
- ✓ Study the pest(s) you plan to control. When is it most vulnerable to fumigants? Where are its numbers the highest?
- ✓ Check and adjust all safety and application equipment. Be sure the components can withstand the corrosiveness of the fumigant(s). When applying compressed gas, use pressure-approved components. Seal them tightly.
- ✓ Locate connections and shut-offs for electricity, water and gas. Test these shut-offs to be sure they are working. Find the nearest telephone or communication device.
- ✓ Obtain and have handy telephone numbers for local health, fire, police and medical emergency services. Know how to contact the parties responsible for the structure and/or commodity you plan to fumigate.
- ✓ ONLY select a fumigant registered by the EPA and ASPB.
- ✓ Read and reread the label information. Study the directions and precautions. Make sure the fumigant is labeled for the required work (site, commodity, etc.).
- ✓ Notify the local health and fire departments, police and security personnel and hospital. Give them the following information: the location, the chemical name(s), the date and time of application, the type of gas mask and other safety equipment required, the fire hazard rating and literature about the safety measures you plan to use.
- ✓ Inform the occupants of the structure where treatment will occur. Also, notify the occupants of neighboring structures.
- ✓ Arrange for standby equipment and replacement parts for application equipment and PPE. Outline an alternate plan of action.
- ✓ Review your treatment plan with all workers. Explain the potential hazards to life and property. Identify the safety measures and emergency procedures that are required by the label.
- ✓ Prepare warning signs to post near treated areas. Arrange for someone to monitor all entrances and exits during treatment.
- ✓ Have first aid equipment (including antidotes and plenty of fresh water) handy.

- ✓ If possible, plan for application from outside the structure.
- ✓ When necessary, obtain fans to evenly distribute the fumigant.
- ✓ Preplan how you will aerate the area after treatment.
- ✓ Identify areas where you can store any excess fumigant(s). Be sure conditions in the storage area match those required by the label information.
- ✓ Make sure no open fires, motors or hot surfaces (heat pipes or electric fixtures) are within the space that you plan to treat.
- ✓ Know how to operate the gas detection devices.
- ✓ Have on hand all the PPE you would need to enter a treated area in an emergency. Check to be sure that this equipment is working properly.

### Pre-Application Safety

*(Appendix A contains a version of this checklist that you can photocopy and use.)*

- ✓ Open all doors and drawers inside the area you plan to treat.
- ✓ Turn off pilot lights and gas lights. Disconnect electrical equipment.
- ✓ Make a final check. Be sure all occupants, pets and livestock have been removed from the structure.
- ✓ Place warning signs at all entrances and exits.
- ✓ Assign someone to observe all entrances and exits.

### During Application Safety

*(Appendix A contains a version of this checklist that you can photocopy and use.)*

- ✓ Apply all fumigants according to the directions in the label information.
- ✓ Apply the fumigant from outside where appropriate.
- ✓ Consider the weather. You may need to delay or cancel outdoor treatments on windy or stormy days.
- ✓ Do not enter the area where fumigant gas is being discharged, except in extreme emergencies.

### Post-Application Safety

*(Appendix A contains a version of this checklist that you can photocopy and use.)*

- ✓ Aerate according to structural limitations.
- ✓ Turn on ventilation fans where appropriate.
- ✓ Before reentering a treated area, use a suitable gas detector to determine the fumigant concentration. Some fumigants do not provide an adequate odor warning. Others aerate slowly.
- ✓ Remove warning signs only when aeration is complete.
- ✓ Dispose of or return empty containers per the manufacturer's instructions.
- ✓ When using metal phosphide fumigants, return any unused, solid chemicals to clearly labeled containers. Store them properly.

### Personnel Safety

*(Appendix A contains a version of this checklist that you can photocopy and use.)*

To protect yourself and others, be sure you and your supervisor(s) always:

- ✓ Know the location of all entrances and exits.
- ✓ Know the location of all fumigant containers and aerating fans.
- ✓ Rehearse the fumigation plan so that each worker knows what to do.
- ✓ Remove all rings, jewelry and watches as required by the label.
- ✓ Have current health records for all employees. All workers that take part in fumigations must have a physical exam at least once a year. During fumigation, no worker should have a cold or other condition that may impair breathing. Nor should any worker be undergoing medical or dental treatment, unless a physician certifies that they may work with fumigants.
- ✓ Survey workers to make sure they have abstained from alcoholic beverages 24 hours before and will abstain 24 hours after a fumigation job.
- ✓ Instruct all workers about first aid, emergency procedures, antidotes and decontamination.
- ✓ Work in pairs, especially when entry into a fumigated area is necessary. Stay in sight of one another while inside a treatment area.

- ✓ Report any accidents to your employer or supervisor.
- ✓ Report any signs of illness or discomfort, regardless of how minor they may seem. This includes dizziness, diarrhea, nausea, headaches and lack of coordination.
- ✓ Teach all workers how to select, operate and maintain protection devices. Warn them about the hazards that they may encounter if the chemicals are misused.
- ✓ Have and use the necessary PPE. Inspect all PPE for defects. Know where emergency equipment is located.
- ✓ Make sure there is enough water on site to wash or flush skin and eyes if an accident should occur.

## Safety Checklists – Soil Fumigation

### Preliminary Planning

*(Appendix A contains a version of this checklist that you can photocopy and use.)*

- ✓ Note the proximity of nearby people and animals. Keep children, unauthorized persons and pets away from the application site.
- ✓ Know the soil you plan to treat. What is its temperature, moisture level and texture? How much organic matter does it contain? Is it well aerated or compacted?
- ✓ Know the pest(s) you plan to control. When is it most vulnerable to fumigants? Which application methods are most effective and efficient?
- ✓ Check and adjust all safety and application equipment. Be sure the components can withstand the corrosiveness of the fumigant(s). When applying compressed gas, use pressure-approved components. Seal them tightly.
- ✓ Be sure that there is a properly-functioning check valve in the line between the cylinder of propellant and the fumigant cylinder.
- ✓ Find the nearest telephone or communication device.
- ✓ Obtain and have handy telephone numbers for local health, fire, police and medical emergency services.
- ✓ ONLY select a fumigant registered by the EPA and ASPB.

- ✓ Read and reread the label information. Study the directions and precautions. Make sure the fumigant is labeled for the desired use.
- ✓ Arrange for standby equipment and replacement parts. Outline an alternate plan of action.
- ✓ Review the fumigation plan with all workers. Explain the potential hazards to life and property, required safety measures and emergency procedures.
- ✓ Prepare warning signs to post near treated areas.
- ✓ Have first aid equipment (including antidotes and plenty of fresh water) handy.
- ✓ Identify areas where you can store any excess fumigant(s). Be sure conditions in the storage area match those required by the label information.
- ✓ Have on hand all the PPE you would need to enter a treated area in an emergency. Check to be sure that this equipment is working properly.

### Pre-Application Safety

*(Appendix A contains a version of this checklist that you can photocopy and use.)*

- ✓ Place warning signs at all appropriate access points.

### During Application Safety

*(Appendix A contains a version of this checklist that you can photocopy and use.)*

- ✓ Apply all fumigants according to the directions in the label information.
- ✓ Consider the weather. You may need to delay or cancel treatments on windy or stormy days.
- ✓ Do not enter the area where fumigant gas is being discharged, except in extreme emergencies.

### Post-Application Safety

*(Appendix A contains a version of this checklist that you can photocopy and use.)*

- ✓ Observe all reentry period, PPE and waiting period specifications on the label for the fumigant that you use.
- ✓ Avoid reentering treated areas when you can still detect the fumigant odor. Although gas

detectors are rarely used with soil fumigation, they may be appropriate in some situations where fumigant concentrations may be high. You will need to use a gas detector when reentering an enclosed structure where soil or potting mixes have been fumigated. Remember that some fumigants do not provide an adequate odor warning. Others aerate slowly.

- ✓ Do not begin planting until after the “waiting period” is over. The waiting period is the number of days between when you apply a fumigant and when aeration is complete.
- ✓ Remove warning signs once the reentry interval has expired.
- ✓ Dispose of or return empty containers per the manufacturer’s instructions.

### Personnel Safety

*(Appendix A contains a version of this checklist that you can photocopy and use.)*

To protect yourself and others, always:

- ✓ Rehearse the fumigation plan so that each worker knows what to do.
- ✓ Remove all rings, jewelry and watches as required by the label.
- ✓ Have current health records for all employees. During fumigation, no worker should have a cold or other condition that may impair breathing. Nor should any worker be undergoing medical or dental treatment, unless a physician certifies that they may work with fumigants.
- ✓ Survey workers to make sure they have abstained from alcoholic beverages 24 hours before and will abstain 24 hours after a fumigation job.
- ✓ Instruct all workers about first aid, emergency procedures, antidotes and decontamination.
- ✓ Work in pairs, especially when entry into a fumigated area is necessary. Stay in sight of one another while inside a treatment area.
- ✓ Report any accidents to your employer or supervisor.
- ✓ Report any signs of illness or physical discomfort, regardless of how minor they may seem. This includes dizziness, diarrhea, nausea, headaches and lack of coordination.

- ✓ Teach all workers how to select, operate and maintain protection devices. Warn them about the hazards that they may encounter if the chemicals are misused.
- ✓ Have and use the necessary PPE. Inspect all PPE for defects. Know where emergency equipment is located.
- ✓ Make sure there is enough water on site to wash or flush skin and eyes if an accident should occur.

## First Aid for Fumigant Poisoning

Even when you take all of the proper precautions, human exposure can still occur. Be prepared. Know what to do for all types of fumigant poisonings.

First, read the label information. The label information is often your best source of first aid information. Federal regulations require that first aid information appear in the label information if a particular hazard exists. Because most fumigants are highly toxic, first aid information is usually listed. Additional first aid information appears on the product’s MSDS.

First aid information in the label information is usually specific to the product. Therefore, you must also be familiar with basic first aid procedures for fumigant exposure.

### Basic First Aid

First aid is just that: it is your first response to fumigant exposure. First aid is not a substitute for medical help. To protect yourself and your coworkers, know when medical attention is needed and seek it right away.

How you respond to a fumigant poisoning depends, to some extent, on whether you or someone else is the victim. In either case, however, you must follow the same basic principles.

If you have been exposed to a fumigant or if you begin to feel ill, remain calm. Get to a doctor right away. Even when the fumigant is less toxic than others are, you may need medical attention, particularly if you were exposed to a large amount of the chemical.

Do not go alone. Have someone take you to the doctor. Be sure to give the label information to the doctor. Keep an extra copy of the label

and MSDS on file for each fumigant that you use. You can take this information to the hospital in case of an emergency without risking container transport.

If you are with someone who has been exposed to a fumigant, begin first aid right away. When possible, get help. First, decontaminate the victim. Take him or her to fresh air. Remove any contaminated clothing. Be careful not to contaminate yourself in the process. If the victim needs medical attention, either call a doctor or take the victim directly to a doctor.

Before, during and after the fumigation process, watch for unusual behavior of yourself and others. It could be a sign of exposure. If you feel sick, do not stay to finish the job. Get to fresh air immediately and get help. If you are with someone who has been exposed to a fumigant, and if his or her breathing stops or is labored, give artificial respiration. Never give anything besides air by mouth to an unconscious person.

Specific first aid treatment varies according to the type of exposure. Learn all of the appropriate procedures. You will not have time or the opportunity to look them up during an emergency.

The two main types of fumigant exposure are inhalation and skin contact.

## Inhalation Exposure

The greatest risk during fumigation is inhalation exposure. Inhalation exposure occurs when someone breathes fumigant gas. Mild exposure by inhalation can cause malaise (a feeling of sickness), ringing in the ears, fatigue, nausea and tightness in the chest. Exposure to fresh air will usually relieve these symptoms. Moderate inhalation poisoning can cause weakness, vomiting, chest pain, diarrhea, difficulty breathing and pain just above the stomach. Symptoms of severe poisoning may occur within a few hours to several days after exposure. Severe poisoning may result in pulmonary edema (fluid in the lungs). This can lead to dizziness, cyanosis (blue or purple skin color), unconsciousness and even death.

Do not attempt to rescue someone in an enclosed area if you are not wearing the proper respiratory protection. If you are with someone who is suffering from inhalation exposure, carry

him or her to fresh air immediately. Do not let the victim walk. Then do the following:

- Call for help – 911.
- Loosen all tight clothing.
- If breathing has stopped or is irregular, give artificial respiration.
- Keep the victim as quiet as possible.
- Prevent chilling by wrapping the victim in blankets. Take care not to overheat the victim.
- If the victim is convulsing, protect his or her head from striking the floor or wall.
- Watch for breathing irregularities that may require CPR. Keep the victim's chin up so that the air passage remains free. Do not put anything in the mouth of an unconscious person.
- Do not give alcohol in any form to the victim.
- Get medical attention right away. Take the victim to a doctor or emergency facility. Take the fumigant's label information with you.

## Skin Exposure

Skin exposure occurs when a pesticide contacts the skin. Liquid and solid pesticides are most often the cause of this type of contamination. However, some fumigant gases can also injure the skin. Skin exposure usually occurs when clothing or jewelry holds the gas tight against the skin. This can cause skin to burn or blister. Fumigants may also be absorbed through the skin and pass into the bloodstream, causing systemic effects.



**Blisters caused by fumigant exposure**

To prevent skin exposure, most fumigant labels suggest that you remove all jewelry and wear loose-fitting clothes. Some labels prohibit the use of gloves. Always consult the label to determine what precautions you should take.

If skin exposure does occur, take the following steps:

- Get to fresh air.
- Remove contaminated items (clothing, jewelry, gloves, shoes, bandages, etc.) immediately.
- Drench the skin with water.
- Wash the skin, hair and fingernails with soap and water.
- Rinse thoroughly and wash again.

- Dry and wrap the affected skin in a blanket.
- If exposure causes a burn, cover the area loosely with a clean, soft cloth. Avoid using ointments, powders and other medications.
- Do not wear contaminated clothes again until you wash them and air them out for several days.

You can never entirely eliminate the risks associated with fumigation. However, if you take precautions, you can significantly reduce them. Take steps to protect the public, yourself and your coworkers. Use the checklists from this manual. Read the label information. Learn about the specific risks of each product you use. Find out what PPE your product requires. Unit 7 will teach you how to select, use and maintain respiratory and gas detection equipment.



## Test Your Knowledge

**Q. Name three agencies that regulate the use of fumigants.**

A. The Environmental Protection Agency (EPA), the Arkansas State Plant Board (ASPB) and the Occupational Safety and Health Administration (OSHA).

**Q. List several things you can learn from reading the label information of a fumigant.**

A. The label information will tell you how and where to use the product. It will give you detailed application and aeration instructions. It may note specific sites that should not be treated, or application methods that are not permitted. The label information also describes specific safety precautions including what PPE to wear and basic first aid procedures.

**Q. How long should warning signs remain posted?**

A. Do not remove warning signs until the treated materials and surrounding area have been completely aerated.

**Q. Name several precautions you must take when transporting a fumigant.**

- A.
1. Do not transport fumigants and people together in a closed vehicle.
  2. Make sure fumigant containers are upright, secured and protected against rear end collision.
  3. Read the label information and/or the MSDS or contact the fumigant manufacturer to determine the signage requirement for transporting each fumigant to you use.
  4. Do not use public transportation to transport fumigants.
  5. Do not transport fumigants through tunnels unless you get permission from ADOT.
  6. Do not remove valve protective covers until just before use.

**Q. What are the two main routes of fumigation exposure?**

A. Inhalation and skin contact.

**Q. What PPE protects you from inhalation exposure to fumigants?**

A. A respirator.

**Q. True or False: You should always wear gloves when working with fumigants.**

A. False. Gloves are not recommended with some fumigants. Others require gloves made of specific materials.

**Q. What are some problems with warning gases?**

A. Individuals vary in their ability to detect odors and levels of odors. Odors only indicate whether the fumigant is present. They do NOT tell you the concentration of fumigant. You may suffer odor fatigue. Over time, you may lose the ability to smell a particular warning agent.

**Q. Explain the difference between TLV-STEL and TLV-TWA.**

A. TLV-STEL stands for “threshold limit value-short term exposure limit.” It is the concentration of fumigant to which most workers can be exposed continuously for a short period without suffering from:

- Irritation
- Chronic or irreversible tissue damage, or narcosis (drunkenness) sufficient to increase the chance of accident or injury

Exposures to concentrations at the STEL should not be longer than 15 minutes and should not occur more than four times per day. The STEL is used to monitor short-term exposure.

TLV-TWA stands for “threshold limit value-time weighted average.” It is the average concentration of fumigant for a normal 8-hour workday and a 40-hour workweek to which workers may be repeatedly exposed without adverse effect. The TWA is used to monitor long-term exposure.

**Q. Describe some symptoms of mild inhalation exposure to a fumigant. What should you do if you or a coworker is experiencing any of these symptoms?**

A. Mild exposure by inhalation can cause malaise (a feeling of sickness), ringing in the ears, fatigue, nausea and pressure in the chest. Exposure to fresh air will usually relieve these symptoms.

**Q. Why do some fumigant labels recommend that you remove jewelry and wear loose-fitting clothes during application?**

A. Jewelry and tight clothing can trap fumigant gas next to the skin, causing irritation or a burn.

# Unit 7. Safety Equipment

## Learning Objectives

After reading this unit, the reader will be able to:

- Choose the most appropriate safety equipment for structures, commodity and soil fumigation.
- Test, fit, maintain and use a respirator properly.
- Select and operate gas detection devices properly.

Fumigants are some of the most toxic pesticides available. Even moderate exposure can be lethal to you and others. Proper use of safety equipment is critical.

This unit describes some of the basic safety equipment used in commodity and soil fumigation. By reading it, you will learn how these devices work and how to use them properly. If safety equipment fails, consequences can be deadly. This unit will help you prevent these failures by properly selecting and maintaining equipment.

## Terms to Know

**Air-Purifying Respirator** – A device that uses special filter media to remove toxic vapors, gases and particles from the air. The filter media come in the form of cartridges, canisters or pre-filters. These fit on a facepiece and are specific for one type of chemical (for example, organic vapors). Air-purifying respirators are also called gas mask/canister combinations.

**Ambient Air Analyzer** – A gas detection device that measures the amount of infrared light absorbed by a gas at a selected wavelength. This tells you what gas is present and its concentration.

**Antidote** – A remedy that may counteract the effects of a pesticide.

**Atmosphere** – The body of air that surrounds a given area. Breathable atmosphere consists largely of nitrogen and oxygen with small amounts of carbon dioxide and other gases.

**Atmosphere-Supplying Respirator** – A device that draws air from outside a fumigation area or uses cylinders of pressurized air to supply a worker with breathable air.

**Calibrate** – To measure and adjust a gas detector so that it reads accurately for the fumigant you use.

**Facepiece** – The part of a respirator that fits over your nose, mouth, face and/or entire head.

**Fumiscope®** – A type of thermal conductivity analyzer that measures the concentration of specific fumigants. It is lightweight, portable and operates on 115 volt alternating current (AC) or battery power.

**Neutralize** – To counteract the effect of a harmful substance such as a pesticide.

**Parts Per Million (PPM)** – The number of parts of a substance in one million parts of another substance. For example, if a gas detector reads “5 ppm,” it means that there are five parts of fumigant to every one million parts of air.

**Respirator** – A device that protects the respiratory tract from irritating and poisonous gases, fumes, smokes and dusts.

**Self-Contained Breathing Apparatus (SCBA)** – A type of atmosphere-supplying respirator that supplies fresh air from a cylinder that is carried by the user. Air enters a mask that tightly covers the entire face.

**Supplied-Air Respirator (SAR)** – A type of atmosphere-supplying respirator that supplies air from a compressed air tank that is located outside of the fumigation area.

**Thermal Conductivity Analyzer (TCA)** – An instrument designed to measure the concentration of fumigant gases within a chamber or other enclosure during fumigation.

## Respiratory Protection Equipment

A respirator is as important to a fumigator as a parachute is to a paratrooper. Both are critical to on-the-job safety. If either device is not regularly inspected, maintained and used correctly, results could be deadly. Remember that fumigants are some of the most toxic pesticides. Breathing even small amounts of these chemicals can be fatal.

Training is crucial for the safe and effective use of respirators. To use respirators during fumigation, you or your employer must establish a formal respiratory protection program. This program must meet all of the requirements

outlined in the Occupational Safety and Health Administration (OSHA) Respiratory Protection Standard (29 CFR 1910.134). These include written operating procedures for the maintenance, cleaning and storage of the respiratory equipment. This program must also contain guidelines for educating respirator users. The information in this manual is not a substitute for the OSHA requirement.

There are two main types of respirators used in fumigation: atmosphere-supplying respirators and air-purifying respirators.

*NOTE: All respirators used by fumigant applicators must be approved by NIOSH (National Institute of Safety and Health). The specific type of respirator required may vary depending on the health of the applicator, the type of fumigant you use and the conditions of its use.*

## Atmosphere-Supplying Respirators

Atmosphere-supplying respirators draw air from outside a fumigation area or use canisters of pressurized air to supply a worker with breathable air.

Fumigators use two main types of atmosphere-supplying respirators: the self-contained breathing apparatus (SCBA) and the supplied-air respirator (SAR). Training is critical for the use of any SCBA or SAR.

### Self-Contained Breathing Apparatus (SCBA)

An SCBA consists of a full-face mask attached to a tank of air carried on the back of the worker. The cylinder of compressed air supplies air to a regulator. The regulator reduces the pressure and delivers breathable air to the facepiece. SCBAs also have an alarm to warn the user when the air supply is low.

Because you carry your air, you do not need to be connected to a stationary source of air. This gives you



the mobility of a canister mask (described later in this unit) and does not restrict movement. However, the weight and bulk of an SCBA often makes strenuous work difficult.

Do not confuse SCBA with SCUBA (self-contained underwater breathing apparatus). These systems are very different. You cannot interchange their uses.

There are two types of SCBA respirators: a demand regulator and a positive pressure regulator.

### Demand Regulator

A demand or negative pressure regulator supplies air to the facepiece when the wearer inhales. This creates a vacuum. Facepieces must fit snugly or contaminated air may leak in.

### Positive Pressure Regulator

A positive pressure regulator allows continuous airflow into the facepiece. The constant positive pressure in the facepiece forces any leaks out of the facepiece.

## Supplied-Air Respirators (SAR)

Like SCBAs, supplied-air respirators are equipped with a full-face mask that delivers air to the fumigator from a compressed air tank or from an ambient air pump. With supplied-air respirators, however, the air tank or pump is located outside the fumigation area.

The most common supplied-air respirator used by fumigators is the "airline respirator." Airline respirators supply compressed air from a stationary source through a long hose. Airline respirators have demand, pressure demand or continuous-flow designs. Air is supplied to a facepiece, helmet, hood or a complete suit depending on the level of protection needed.

The demand or pressure-demand airline respirator operates

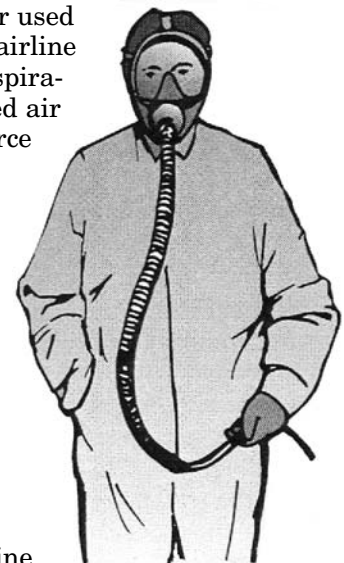

**Airline respirator**

much like a demand SCBA respirator. The difference is that an airline system supplies air through a hose connected to a stationary air source, whereas the fumigator carries the SCBA air supply.

Continuous-flow airline respirators provide breathing air continuously rather than on demand. These are much like the positive pressure SCBA respirators. Instead of a regulator, however, these respirators have an airflow valve that partially controls the airflow. In addition, air is supplied by a stationary source, whereas SCBA air tanks are portable.

There are several advantages to airline respirators. Unlike SCBA respirators, airline respirators provide long, continuous use. They are lightweight and offer minimal breathing resistance and discomfort. Airline respirators also have a moderate initial cost and a low operating cost.

Unfortunately, there are drawbacks to airline respirators as well. For example, if something cuts, burns, kinks or crushes the hose, the wearer has no air. Also, compressors may fail or the storage tank may become empty. For these situations, there are airline respirators with auxiliary air supplies. Airline respirators can also restrict movement. Because the wearer is attached to a long hose (200 feet maximum) there are limits to how far and in what direction he or she can move.

## Air-Purifying Respirators

Air-purifying respirators combine a tight or loose-fitting facepiece with a specific filter media. When you breathe in, you draw air from outside the respirator, through filter media and into the mask. The filter media absorb impurities as the air passes through. Air-purifying respirators are also called “gas mask/canister combinations.”

*NOTE: The three most common types of filter media used with air-purifying respirators are canisters, cartridges or pre-filters. For simplicity, we will refer to all three types of filters as “canisters” for the remainder of this manual.*

Many air-purifying respirators have tight-fitting full facepieces. These are similar to the facepieces used for SCBAs and SARs. However, the valves and gaskets for facepieces used with atmosphere-supplying respirators are very different than those used for air-purifying respirators. Do not use them interchangeably. You

can also use half-mask air-purifying respirators in some fumigation situations.

Another option is the “powered air-purifying respirator.” Some powered air-purifying respirators do not include a gas mask at all. Instead, they use a small electrical motor to pull air through a pre-filter and cartridge. The motor then moves the filtered air through a hose to a helmet where the air blows down over the face of the wearer.

Gas mask/canister combinations are approved only for specific fumigants. There are many different types of canisters. Each one is color coded with stripes. The stripes indicate limitations and approved uses for quick and easy recognition. For example, a gray stripe around the top of a canister indicates the presence of a filter that removes dust and other particles. Other color combinations identify canisters for specific fumigants.



**Gas mask/canister combination respirator**

Before using any air-purifying respirator, make sure you have been fit-tested and approved by a licensed health care professional. In addition, be sure that all parts and replacement parts meet manufacturer specifications.

How long a canister will last depends on several things:

- The type of canister
- The size of the canister
- The type and concentration of gas in the surrounding air
- The length of exposure
- The rate of breathing
- Whether there is more than one gas present
- The temperature and humidity at the time of use

Never use a canister after the expiration date. An expiration date is usually listed somewhere on the canister. OSHA requires you to develop a cartridge change-out schedule when the canister does not have an end of service life indicator (ESLI). This schedule must be specific to the treatment site, the type of fumigant you use, the concentration of the fumigant, the exposure time, the temperature and humidity in the treatment area and other factors.

## How Air-Purifying Respirators Work

When properly assembled and fitted, air-purifying respirators protect against the gases or vapors listed on the canister label. Powered air-purifying respirators pull air through the canister, which then neutralizes or absorbs harmful gases and vapors. For other types of air-purifying respirators, inhalation by the wearer pulls air through the canister. The purified air then passes through corrugated rubber tubing into the molded channels of the facepiece. Some of these channels direct the purified air to the lenses to reduce fogging.

When you exhale, air is expelled from the facepiece through a valve designed to permit normal conversation. This valve also serves as a drain for moisture produced by breathing. An inhalation valve at the bottom of the canister prevents the exhaled air from passing out through the canister.

Always read the label information to determine which type of respirator to use. Wearing the proper personal protective equipment (PPE) will protect you and your coworkers. It is also the law.

## Care of Respiratory Protection Equipment

All applicators should have their own respirator and canister. Do not share your canisters with others. In fact, it is best if you do not reuse canisters at all. If you must reuse a canister, keep a written record of the date used, length of time used and gas concentration. Destroy or mutilate the tops of canisters that are no longer usable. Never reuse a canister if it has been used in an emergency.

Clean and disinfect your respirator after each use and at least once a month. To sanitize

masks, prepare a solution of cleaner-sanitizer (available through your respiratory protection supplier) and warm water. Immerse the mask in this solution. Scrub the interior and exterior of the mask with a sponge. Rinse the mask with warm water and air dry. If you are not able to sanitize the mask immediately, wipe out the interior with a clean cloth. Use soap and warm water if possible.

During cleaning, inspect the mask. Look for any loose connections and rubber deterioration. Check the integrity of the facepiece seal. For air-purifying respirators, inspect the inhalation valves, exhalation valves and straps. Keep a record of all cleanings and inspections.

After cleaning and inspection, place the mask in its carrying case to protect it against dust, sunlight, heat, extreme cold, moisture or damaging chemicals.

If your respirator needs repairs, be sure to use parts designed specifically for that respirator and approved by the manufacturer. Only experienced persons should repair a respirator. Atmosphere-supplying respirators must be sent to the manufacturer for repair.

## Fitting and Testing the Respirator

Respirators come in different sizes. Be sure yours is the right size for you. In addition, respirators must be fit-tested to their user. For a firm and comfortable fit of your facemask, adjust the headbands in this order:

1. Make sure the straps lie flat against your head.
2. Tighten the lower or neck straps.
3. Tighten the head cradle straps.
4. Place both hands on the headband or head cradle and position it on the crown of the head.
5. Repeat steps one and two.
6. Tighten the forehead or front strap a few notches.

The mask should feel comfortable, while forming a tight seal against your face. Facial hair will prevent a tight seal. Workers with beards and/or large mustaches must shave. OSHA requires that respirators fit properly and that you test their facepiece-to-face seal.

There are two types of “fit tests,” qualitative and quantitative. Qualitative fit tests rely on subjective sensations – taste, irritation and smell – of the respirator wearer to a particular test agent. Quantitative tests use measuring instruments to measure face seal leakage. The type of test you should use depends on many things.

Once you find a respirator with a good fit, testing is not over. You must also check the respirator each time you wear it. Here are two quick field tests. These are called “user seal checks.”

## Negative Pressure Test

The negative pressure test allows you to check full-face and half-face tight-fitting respirators for proper fit before each use. First, pinch off the breathing tube or cover the inhalation valves with the palm of your hand. Then, inhale to create “negative pressure.” The facepiece should collapse. Hold your breath for 10 seconds. A respirator with a tight seal will remain collapsed while you hold your breath. If it is leaking, check the cartridge connections, valves and straps and repeat the test.

## Positive Pressure Test

The positive pressure test is usually included in the manufacturer instructions. First, place the palm of your hand or thumb over the exhalation valve. Then, exhale gently into the respirator, causing “positive pressure” inside the facepiece. If you do not feel any air leaking out of the facepiece, the respirator fits properly. If it is leaking, adjust the straps and test again. If the leak persists, inspect the respirator for problems. Check the hoses and connections to make sure they are tight and in good condition. A new rubber washer for the mask hose is supplied with each new canister. This washer must be in place when attaching the hose to the canister. Otherwise, vapors can enter through the mask hose. Be sure to check for this washer. If the leak still exists, try installing a new corrugated breathing tube. If this takes care of the leak, destroy the defective breathing tube. If, after removing your hand from the canister inlet, you find you cannot breathe, the canister has a blockage. Destroy and replace the canister. If the respirator is an air-supply type, check the facepiece and breathing tube. If the respirator is an SCBA, check the air tank for amount of air,

leaks and valve efficiency. For SARs, test the valves, connections and hoses.

# Use of Respiratory Protection Equipment

No matter what type of fumigation you are performing, your respirator should be ready to use at all times. When it is not in use, have it on hand for emergencies. Keep the following list nearby. It will help you to inspect and use your mask properly.

- Before using any air-purifying respirator, make sure that all parts and replacement parts meet manufacturer specifications.
- If you use an air-purifying respirator, check the canister for an expiration date. If canisters are used more than once, be sure enough time remains. When in doubt, use a new canister.
- Select the proper canister for the fumigant you plan to use. The canister label will indicate for which fumigant(s) it is approved.
- If you use a new canister, install the new washer that comes with it. Remove the tape that covers the intake port on the bottom of the canister.
- Connect the mask and canister.
- Put the mask on while you are in fresh air.
- Check for proper fit and leaks.
- Check the time. Note when you should be out of the fumigated area.
- Enter the contaminated area slowly. Return to fresh air immediately if you notice irritating gases, odors or symptoms of distress.

### After completing the job:

- Clean and inspect the respirator.
- Record the date of cleaning. If you plan to reuse the canister, record how long you used it. Also, note the fumigant and its concentration.
- If you used all of the canister’s time, mutilate the top so that it cannot be reused and discard it.
- Return the respirator to its carrying case. Place both items in a proper storage area.

### **When fumigating raw agricultural commodities, be sure to:**

- First, monitor the air quality. If the air contains less than 19.5% oxygen, it is deficient. Use an air-supplying respirator and not a gas mask/canister combination. When in doubt, always use an air-supplying respirator.
- Check the time. Note when you should be out of the fumigated area.
- Enter the contaminated area slowly. Return to fresh air immediately if you notice irritating gases, odors or symptoms of distress.

## **Gas Detection Equipment**

Gas detectors monitor and record gas concentrations before, during and after treatment. They are a part of every fumigator's operational and safety equipment for treatments within enclosed spaces and structures. However, gas detectors are rarely used with soil fumigation.

You can use detectors to eliminate some of the common hazards associated with fumigation. Use them to:

- Indicate fumigant levels during treatment
- Detect excessive leaks in a building or poor tarp seals, and determine the dosage requirements for future fumigation

Detectors also measure the success of aeration by monitoring the presence or absence of fumigant vapors.

Be sure the accuracy and range of your detector is suitable for the fumigant you plan to use. Some detectors are more sensitive than others are. Calibrate your detector for each fumigant you use. Be sure you know how to read it.

There are several gas detectors from which to choose. The following are some of the most commonly used in fumigation.

## **Halide Gas Detectors**

The halide gas detector indicates the presence and approximate concentration of halide gases – gases that contain any of five nonmetallic halogen elements: fluorine, chlorine, bromine, iodine and astatine. It is most

commonly used to measure levels of methyl bromide. It reliably measures gas concentrations of 50 parts per million (ppm) or greater.

Halide detectors consist of:

- A fuel tank
- A valve assembly (to regulate fuel flow), a burner head assembly (where the fuel and air mix and unite)
- The reaction plate or cone assembly (where the visible flame reacts to halogen gases)

An attached search hose feeds the air mixture to the burner head assembly for testing. The fuels used include kerosene, alcohol, acetylene, and propane. These are available at refrigeration supply dealers.

To operate a halide detector, hold a lit match in the window opening of the burner tube. Turn the valve slowly to the left. After the copper plate or cone turns red, adjust the flame to the smallest size to maintain that color. The detector is now ready to test the air. Hold the open end of the search hose on, in or near the article or area to be tested. As air passes over the heated plate or cone, the flame color will change if a halogen gas is present. The color and intensity of the flame indicates the concentration of the gas. A color chart with corresponding gas concentrations comes with each detector.

*NOTE: If you use a halide detector at night, the flame will have a bluish cast. You must consider this when reading the results.*

Unfortunately, no halide detectors are accurate for determining exactly how much gas is present. They will only give you an estimate.

Because halide detectors have an open flame, you must adhere to all safety precautions. Even when the detector is not in operation, do not store it in a frequently inhabited room. The fuel is a flammable gas under pressure and may explode. Do not use halide detectors in the presence of flammable or explosive gases such as gasoline vapors.

Do not use halide detectors in mills, grain elevators or other enclosures where there is a possibility of a dust explosion. Always read the label to determine the flammability of the product you are using.

Halide detectors need little maintenance. The burner head orifice is very small.



Prevent dust and other debris from clogging it. Occasionally, you will need to replace the reaction plate or cone.

The halide gas detector has been used for many years. It is an operational as well as a safety device. By detecting leaks, it can help you to reduce harmful gas levels outside the treatment area. This will increase the safety and efficacy of your operation. As a precaution, use a halide detector regularly in rooms that house fumigation chambers. This is particularly important when the building also contains offices or other work areas.

*NOTE: Do NOT use a halide detector to determine whether fumigant levels are safe for reentry. While the halide detector is useful for detecting low levels of halogenated fumigants, it should NOT be used to detect harmful concentrations of these fumigants. The reentry threshold concentrations for a number of fumigants are lower than the detection limit of the halide detector.*

## Thermal Conductivity Analyzers

Thermal conductivity analyzers (TCAs) measure the concentration of fumigant gases within a chamber or other enclosure during fumigation. Several types of TCAs are available.

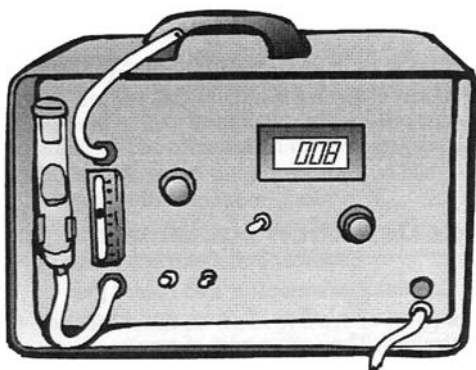

Fumisscope®

The Fumisscope® is one of the most common TCAs. It is primarily used to measure methyl bromide concentrations. The Fumisscope® is lightweight, portable and comes in a compact cabinet. It operates on 115 volt AC (alternating current) or battery power. In a Fumisscope®, electrical currents pass through a wire exposed to the sampled air. The temperature of the wire is affected by the composition of the air around

it. The hotter the wire, the higher the fumigant concentration. The fumigant concentration is displayed on the Fumisscope® meter.

When using TCAs, keep in mind that most of them are sensitive to several gases, not just the one for which you are testing. For a true reading, you must eliminate other gases. For example, carbon dioxide (CO<sub>2</sub>) may occasionally be a problem. If a prefumigation test indicates high levels of CO<sub>2</sub>, place a tube of sorbing material such as sodium hydrate in the sampling line. It will absorb CO<sub>2</sub>, allowing the TCA to give you a more accurate reading.

When you run long sample lines into the fumigated area, use a small pump to draw air from the test point to the end of the line. This speeds up the readings.

*NOTE: Like the halide detector, TCAs should NOT be used to determine whether fumigant levels are safe for reentry. They cannot measure gas concentrations below 5 ppm.*

## Glass Detector Tubes

Glass detector tubes or “color diffusion detector tubes” are another gas detection option. Unlike other detectors, glass tubes are disposable. You can only use them once. Glass detector tubes are often more sensitive and more specific than halide detectors and TCAs. They can detect specific fumigants at lower levels than other gas detectors.

Glass detector tubes are “fumigant specific.” That means you will need to purchase a different set of tubes for each type of fumigant you use. Their operation is simple. Place one tube in the area you wish to test. Break the seal. Use a manual pump to draw a measured amount of air through the tube. Different pumps and tubes require a different number of pump strokes. Follow manufacturer recommendations. A color reaction will occur indicating the fumigant concentration. A color chart with corresponding concentrations is printed directly on the tube.



Detector tubes are available for many fumigant gases. Both high-range and low-range tubes are available for some fumigants. Use the high-range tubes to determine gas concentrations during fumigation. Use the low-range tubes to assure safe working conditions after aeration and before reentry.

## Ambient Air Analyzers

Some ambient air analyzers or “infrared detection systems” use infrared spectrophotometers to detect and measure gas concentrations. This is how they work. When infrared radiation strikes a gas, certain wavelengths of the radiation are absorbed. The spectrophotometer measures this absorption. The amount of radiation absorbed indicates the gas concentration. Most ambient air analyzers can be calibrated at the factory to detect a single gas. Others are equipped with a fixed infrared filter.

Portable units weigh about 18 pounds. They are equipped with both AC and battery power. Each unit has two scales. The lower scale is accurate from 0 to 15 ppm. Use it to check fumigation sites before reentry. The upper scale functions as a leak detector during fumigation. It detects concentrations from 0 to 150 ppm.

## Gas Analyzers

Gas analyzers detect leaks during fumigation. They also determine if a site is ready for reentry. Several models are available. The most popular are lightweight and battery powered. Most are designed to monitor concentrations of a particular gas. One model uses a pump to draw an air sample through a tiny furnace. Any fumigant present passes through a sensor that detects how much gas is present. Readings are given in ppm.

## Other Protection Equipment

Whenever possible, provide two-way radio communication between workers applying fumigants and those outside. Also, keep on hand:

- An emergency air-supplying respirator, especially if canister-type respirators are being used
- Antidotes where applicable
- A safety harness or rescue belt
- Basic first aid equipment

## Test Your Knowledge

**Q. Name the two types of respirators most often used by fumigators. Describe the difference between them.**

- A. 1. An atmosphere-supplying respirator draws air from outside a fumigation area or uses cylinders of pressurized air to supply a worker with breathable air.
2. An air-purifying respirator or “gas mask/canister combination” uses special canisters to remove particles and toxic vapors from fumigated air.

**Q. Name two types of atmosphere-supplying respirators. Explain the advantages and disadvantages of each one.**

- A. 1. A self-contained breathing apparatus (SCBA) gives the operator greater mobility but offers a limited amount of air. The weight and bulk of an SCBA apparatus can also make strenuous work difficult.
2. A supplied-air respirator (SAR), such as an airline respirator, has the advantages of longer continuous use and a lighter weight. However, because you are connected to a stationary source, movement may be restricted. In addition, if something cuts, burns, kinks or crushes the hose, the wearer has no air.

**Q. What does the stripe around the top of an air-purifying canister indicate?**

- A. The type of material the filter in the canister will remove from the air.

**Q. If an air-purifying canister has expired, what should you do to it before you throw it away?**

- A. Destroy or mutilate the top so that it is no longer usable.

**Q. Describe the procedure for fitting a respirator mask.**

- A. 1. Make sure straps lie flat.

2. Tighten neck straps.
3. Tighten side straps.
4. Push headband pad downward.
5. Repeat steps one and two.
6. Tighten front strap a few notches.

**Q. Describe the two methods currently accepted by OSHA to fit test a respirator.**

- A. 1. Qualitative fit tests rely on subjective sensations – taste, irritation and smell of the respirator wearer to a particular test agent.
2. Quantitative tests use measuring instruments to measure face-seal leakage.

**Q. Once you find a respirator with a good fit, testing is not over. Describe two “user seal checks” you should perform each time you wear your respirator.**

- A. 1. Negative Pressure Test: Pinch off the breathing tube and inhale so the face-piece collapses. Hold your breath for 10 seconds. The facepiece should stay collapsed for this time. If it does not, the mask does not fit properly and fumigant may leak in.
2. Positive Pressure Test: Press your thumb over the valve guard and exhale. Do you feel any air leaking out? If so, the mask does not fit properly and fumigant may leak in.

**Q. What information do gas detectors provide?**

- A. Gas detectors indicate fumigant levels during treatment and aeration. They can detect leaks in structures or under tarps during fumigation. They can help determine the dosage requirements for future fumigation. Detectors also measure the success of aeration by monitoring the presence or absence of fumigant vapors.

**Q. What type of gas is dangerous to measure with a halide detector? Why?**

A. A flammable gas because halide detectors operate with an open flame. Always read the label information to determine the flammability of the product(s) you use.

**Q. What is the most common type of thermal conductivity analyzer (TCA)?**

A. The Fumiscope®.

**Q. When using a TCA, how can you avoid a false reading due to the presence of gases other than the one you are measuring?**

A. Place a material that will sorb the gas you do not want to measure into the sampling line.

**Q. What type of gas detector is disposable?**

A. Glass detector tubes.

**Q. What types of gas detection equipment can be used to determine whether fumigant levels are safe for reentry?**

A. Glass detector tubes, ambient air analyzers and gas analyzers.

# Unit 8. Common Fumigants

## Learning Objectives

For each fumigant discussed in this unit, the reader will be able to

- Describe basic application and aeration techniques.
- Understand its mode of action.
- Use it safely and effectively.
- Know which detection equipment best measures its concentration.
- Dispose of its residues and empty containers in a safe and legal manner.

This unit discusses some of the most common fumigants used to treat soil and raw commodities. By reading it, you will understand how each of these fumigants works and how to use them effectively. This unit will explain basic application and aeration procedures. You will learn the risks each chemical poses. You will discover how to protect yourself and others from exposure. Selection and use of detection equipment is discussed. This unit will also outline how to properly dispose of fumigant residues and empty fumigant containers.

## Terms to Know

**Bonnet** – The cap that covers the valve and safety cap on a fumigant cylinder. The bonnet protects the valving system from damage and prevents accidental release of the fumigant.

**Chemigation** – The application of a pesticide through an irrigation system.

**Corrosive** – Able to weaken or destroy something gradually.

**Deactivate** – To make something ineffective. For example, by deactivating fumigant residue, you would neutralize its toxic effects.

**Emulsifiable Concentrate (EC)** – A liquid pesticide formulation that helps you apply an active ingredient(s) that does not readily dissolve in water. The water-insoluble active ingredient(s) is dissolved in an organic solvent with an “emulsifier.” The emulsifier disperses the formulated product into tiny droplets when added to water.

**Exposure Period** – The period of time after fumigation during which the fumigant is allowed to diffuse through the material being treated in order to maximize “exposure” of the target pest(s) to the fumigant.

**Formulation** – The specific mixture of active ingredient(s), other additives, and a carrier in which a pesticide is offered for sale to the user. Examples include emulsifiable concentrations, pellets, etc.

**Germination** – The process by which a spore or seed begins to grow or sprout.

**Inert** – Having no chemical activity. Not reactive.

**Liberate** – To set free. To release.

**Prepac** – Aluminum phosphide fumigant tablets that are packed in a gas-permeable material.

**Residue** – Traces of fumigant that remain after treatment.

**Sprigging** – Transplanting pieces or “sprigs” of grass.

**Threshold Limit Value (TLV)** – The maximum amount of fumigant that can be in the air before conditions are considered unsafe. The TLV is expressed in parts per million (ppm). It is used to monitor short-term exposure.

**Threshold Limit Value-Time Weighted Average (TLV-TWA)** – The average concentration of fumigant for a normal 8-hour workday and a 40-hour workweek to which workers may be repeatedly exposed without adverse effect. The TLV-TWA is expressed in parts per million (ppm). It is used to monitor long-term exposure.

There are a limited number of fumigants on the market. Each has its own advantages, disadvantages, uses and limitations. This unit does not intend to indicate a preference toward any one fumigant. You must make your own choice based on the label information, the pest and the commodity or soil that is infested. Since there is some overlap between soil and raw commodity fumigants, we will not attempt to divide them into these two categories. Instead, we will discuss the many uses of each chemical.

# Common Fumigants

## Disclaimer

Just because a fumigant appears in this manual does not mean that it is legal to apply. Laws and regulations governing pesticides change often. Fumigants described here may no longer be legal. Always check current laws and regulations before using any **fumigant for any purpose. For example**, at the time of this writing, methyl bromide has been labeled an ozone-depleter. As a result, this widely used fumigant may soon be banned. Keep up-to-date on the state and federal laws and regulations that apply to you.

## Sulfuryl Fluoride

Sulfuryl fluoride (ProFume® or Vikane®) is a colorless, odorless and tasteless toxic gas. It is heavier than air and tends to initially settle in low areas. It is nonflammable. However, heaters, pilot lights and open flames must be extinguished, as temperatures above 752°F will cause decomposition products to be formed which can be corrosive and can etch glass and metal. Refer to ProFume and Vikane fumigation manuals and labels before usage and for any changes in use that may have occurred from the registration process. **Sulfuryl fluoride is toxic to most living organisms including humans.** In case of over exposure, get medical attention immediately.

## Formulations

Sulfuryl fluoride comes in pressurized cylinders (containers). ProFume and Vikane are restricted use products. Cylinders are under pressure, 303 psi @ 90°F, and must not be stored near heat or open flame. Exposure to temperatures above 158°F will cause a fusible plug to melt and the contents will be released. Always store and transport cylinders in a secure upright position. Cylinders of sulfuryl fluoride should be stored in a dry, cool, well-ventilated, secure and locked area. Post as pesticide storage area.

## Uses

This fumigant is very effective against insect larvae and adults, but requires higher doses for insect eggs. Do not use for insect control when temperature at the site is below 40°F.

## Sulfuryl fluoride at a glance:

### Required clothing:

- Use splash-resistant goggles or full-face shields when handling the liquid, such as opening the cylinder to introduce gas into a structure. Liquid sulfuryl fluoride can freeze the eye tissue.
- Wear loose-fitting or well-ventilated long sleeve shirt, long pants, shoes and socks.
- Do not wear gloves.
- Do not wear rubber boots.

### Respiratory protection:

- For ProFume use in commodities, concentrations of 1 ppm or less require no respiratory protection. Concentrations above 1 ppm require NIOSH/MSHA approved SCBA or combination air-supplied respirator/SCBA, such as those manufactured by Ranger, Survivair, Scott or MSA.
- For Vikane use in structures, concentrations of 5 ppm or less require no respiratory protection. Concentrations above 5 ppm require NIOSH/MSHA approved SCBA or combination air-supplied respirator/SCBA required, such as those manufactured by Ranger, Survivair, Scott or MSA.
- If (emergency) re-entry into a structure under fumigation, prior to complete aeration, with sulfuryl fluoride is required, the proper respiratory protection (SCBA) must be used.

## ProFume Uses

- What – For control of insects pests for the commodities listed on label, such as confused flour beetle, red flour beetle, sawtoothed grain beetle, warehouse beetle, Indianmeal moth, Mediterranean flour moth, codling moth, navel orangeworm, granary weevil, rice weevil and other moths and beetles as well as rodents. Area around fumigation must be monitored using a detection device such as INTERSCAN gas analyzer or MIRAN vapor analyzer to ensure that workers without respiratory protection are not exposed to

concentrations of sulfur dioxide exceeding **1 ppm**.

- Where – Non-residential structures (for the food commodities listed on the label) such as mills, warehouses, stationary transportation vehicles (railcars, trucks, etc., excluding aircraft and passenger railcars), temporary and permanent fumigation chambers and storage structures. For use in food-processing establishments containing only those commodities listed on the label. Not for use in other food-handling establishments.
- Do not use ProFume without the Fumiguide Program for ProFume Gas Fumigant. The ProFume Fumiguide is part of labeling for ProFume and must be used to calculate the dosage. Never allow untrained individuals to apply ProFume gas fumigant.
- **Read product label for any usage changes and further definition of uses or prior to fumigation.**

## Vikane Uses

- What – Control of existing infestation of insects and related pests such as (or including) drywood termites, Formosan termites, powderpost beetles, death watch beetles, old house borers, bedbugs, cockroaches, clothes moths, rodents (rats, mice) and the larvae and adults of carpet beetles (except egg stage), oriental, American and brownbanded cockroaches.
- Where – Dwellings (including mobile homes), buildings, construction materials, furnishings (household effects) and vehicles including automobiles, buses, surface ships, rail car, and recreational vehicles (but not including aircraft). Area around fumigation must be monitored using a detection device such as INTERSCAN gas analyzer or MIRAN vapor analyzer to ensure that workers without respiratory protection are not exposed to concentrations of sulfur dioxide exceeding **5 ppm**.
- **Read product label for any usage changes and further definition of uses or prior to fumigation.**

## Application

Sulfur dioxide does not adversely react with other compounds. However, all flames, including pilot lights, must be extinguished. All electrical heating elements must be turned off or unplugged. Temperatures above 752°F will cause

decomposition products to be formed which can be corrosive and etch glass and metal.

Because sulfur dioxide is odorless, colorless and tasteless, chloropicrin must be used as a warning agent when using Vikane. Pour chloropicrin (one ounce per 10,000 to 15,000 cubic feet) onto some cotton in a shallow pan. Do not use evaporation containers or application equipment made of magnesium, aluminum or their alloys, as chloropicrin may be severely corrosive to such metals. Place the pan in front of a fan. Allow 5 to 10 minutes for the chloropicrin to circulate before introducing the sulfur dioxide. When adding chloropicrin to evaporation containers, do not dispense more than 3 fluid ounces per container. Use one chloropicrin introduction site per 45,000 cubic feet to be fumigated.

Introduce sulfur dioxide from the outside through tubes. Use polyethylene, polypropylene or strong nylon tubing with an internal diameter of 1/8 to 1/4 inch. The tubing should have a minimum burst pressure of 500 pounds per square inch (PSI). The rate of fumigant released through larger tubing would be too great for good gas distribution. Place fans throughout the fumigation area. Run the fans during introduction and for at least 60 minutes afterward. For ProFume, Dow recommends leaving the fans running for the duration of the fumigation. Fans aid in the introduction, distribution and the aeration process for sulfur dioxide. Fans will circulate the gas ensuring good distribution. If desired, use a remote shut-off such as a timer to turn off the fans.

Do not use sulfur dioxide at temperatures below 40°F. To prevent damage, do not apply sulfur dioxide directly to any surface.

## Precautions

If the concentration of sulfur dioxide is unknown or exceeds 1 ppm for ProFume or 5 ppm for Vikane, all persons in the exposed area must wear a self-contained breathing apparatus (SCBA) or a combination air-supplied/SCBA respirator.

Always wear (safety) splash resistant goggles or a face shield while releasing sulfur dioxide. However, you **should not wear rubber boots or gloves** when introducing sulfur dioxide. These may trap the liquid against your skin and cause injury.

When fumigating with Vikane any food, feed or drug item must be placed in Nylofume bags or removed before fumigation. Because the gas can get into frost-free refrigerators and freezers,

you must either bag the contents of these appliances or remove their contents from the fumigated space. Additionally, open or remove items that might slow fumigant aeration, such as waterproof mattress covers. Do not use sulfuryl fluoride on living plants.

In transit fumigation, including aeration, of any vehicle is prohibited on public roads or waterways.

Product labels require that the structure be posted with specific warning signs on all entrances and all sides during the exposure and aeration period until the building is cleared for reentry by the fumigator.

## Aeration

Aeration is rapid. Sulfuryl fluoride desorbs quickly. Follow the aeration procedures in the label information to determine your aeration time.

## Detection

Use the Fumiscope® (a thermal conductivity analyzer) to monitor sulfuryl fluoride levels during application. The Fumiscope® can detect sulfuryl fluoride at levels greater than 240 ppm.

When measuring gas concentrations for reentry, however, you will need to use a different type of gas detector. Only approved detection devices of sufficient sensitivity, such as specific types of gas analyzers or infrared detection systems (ambient air analyzers), can be used to confirm a concentration of sulfuryl fluoride of 1 ppm or less. At the time of this writing, the sulfuryl fluoride product label requires the use of an INTERSCAN or MIRAN analyzer, or similar approved device to measure gas concentrations for reentry.

## Disposal

When a sulfuryl fluoride cylinder is empty, close the valve, screw the safety cap onto valve outlet and replace the protection bonnet. Return the empty cylinder promptly to the distributor. Do not use the cylinder for any other purpose.

**As with any Restricted Use Pesticide, carefully read and follow all label instructions. When using ProFume Gas Fumigant, the fumigator must also read and follow the ProFume Gas Fumigant Fumigation Manual as it is part of the label. All persons desiring to use sulfuryl fluoride, as Vikane or ProFume, must comply with Dow AgroSciences product stewardship policies.**

# 1,3-Dichloropropene

## 1,3-Dichloropropene at a glance:

### Required clothing:

#### Outside an enclosed tractor cab:

- Coveralls over a short-sleeved shirt and short pants.
- Chemical-resistant gloves as listed in the label information.
- Chemical-resistant footwear plus socks.
- Face-sealing goggles, unless a full-face respirator is worn.
- Chemical-resistant headgear for overhead exposure.
- Chemical-resistant apron when performing direct contact tasks.

#### Inside an enclosed tractor cab:

- Coveralls.
- Shoes and socks.
- Face-sealing goggles, unless a full-face respirator is worn.
- Additional clothing for direct contact activities must be immediately available and must be worn if the handler leaves the enclosed cab to perform any direct contact activity.

### Respiratory protection:

#### Outside an enclosed tractor cab:

- A National Institute of Safety and Health (NIOSH)-approved respirator with a canister approved for pesticides or an organic-vapor-removing cartridge with a prefilter approved for pesticides.

#### Inside an enclosed tractor cab:

- A NIOSH-approved, half-face respirator with a canister approved for pesticides or an organic-vapor-removing cartridge with a prefilter approved for pesticides.

#### In high concentration conditions (large spill cleanup, poor ventilation):

- A NIOSH-approved supplied-air respirator or self-contained breathing apparatus (SCBA).

### Uses:

- What: Soil.
- Where: Agricultural fields. Not for use in greenhouses or other enclosed areas.



1, 3-dichloropropene (1, 3-D) usually comes as a colorless to straw-colored liquid with a pungent, sweet, penetrating odor. It is flammable, highly mobile in soil and toxic to many organisms, including aquatic organisms and humans.

## Formulations

Products that contain only 1,3-D are over 90 percent pure. These mixtures are formulated as emulsifiable concentrates (ECs) and non-emulsifiable concentrates (Non-ECs). Application of 1,3-D as an EC is restricted to use with drip irrigation systems. You can also combine 1,3-D with chloropicrin to create a multipurpose fumigant. Non-EC formulations are packaged in pressurized cylinders of varying sizes. Most come in large “mini-bulk” containers.

## Uses

1,3-D is used for soil fumigation only. It is most often applied to control plant-parasitic nematodes. However, it will also control or suppress certain insects and diseases. Read the label to be sure 1,3-D will control the pest or disease you wish to target.

## Application

You can apply 1,3-D products as row treatments or by broadcasting them over entire fields. The most common formulation of 1,3-D is the non-EC. Use “ripper-bedders” for row application of non-ECs. A ripper-bedder is a subsoil shank followed by two bedder disks. Together, these are attached to a toolbar and perform a single operation. The shank fractures the hardpan in the soil, while the disks throw a mound of soil over the slit left by the shank. For broadcast fumigation, use chisel or bottom plows. Apply non-ECs through equipment that moves the product from a tank into the soil via pressure from a cylinder of nitrogen gas or from a pump – power take-off (PTO), electrical (explosion-proof) or ground-driven. During application, maintain operating pressures between 10 and 50 pounds per square inch (psi).

Apply EC formulations of 1, 3-D through a surface or buried drip irrigation system for each row. Space drip emitters 12 to 24 inches apart on the driplines. Cover each treated row with tarp for at least 14 days after application.

## Precautions

1,3-D products should only be used to treat soil. Do not use them in confined spaces such as

greenhouses or in areas where fumes can enter nearby dwellings.

Do not use 1,3-D products with equipment that contains aluminum, magnesium, zinc, cadmium metals or their alloys, or galvanized materials. 1,3-D is highly corrosive to these materials. Polyvinyl chloride (PVC), ethylene propylene diene monomer (EPDM), Buna-M, neoprene and fiberglass may also dissolve upon contact with products that contain 1,3-D. Finally, do not use 1,3-D with rubber.

During application of 1,3-D, be sure that:

- Sight gauges on all application tanks have shut-off valves
- All tank fittings are fumigant-resistant (brass or nylon)
- All seals are made of Viton®
- Transfer systems are the dry-disconnect type

Do not allow smoking within 50 feet of containers or equipment that contains 1,3-D. A full eyewash bottle and at least 5 gallons of clean water should be available to each person who handles 1,3-D. Restrict entry into the fumigated area until five days after treatment. Notify workers of an application verbally, as well as by posting warning signs at the entrances to treated area.

Check and replace hoses, check valves, strainers, tanks and seals in soil fumigation equipment regularly. Before application, flush your equipment with diesel fuel or water to check for leaks or other problems. If you use water, pump out or drain the water before filling the equipment with fumigant. Flush application equipment with diesel fuel after each use. Dispose of flush material according to local, state and federal regulations. Fill any pumps with new motor oil or a 50 percent motor oil/fuel oil mixture before storing them. Store application equipment in a location that protects it from sunlight and weather.

## Aeration

Exposure periods for 1,3-D should range from 7 to 14 days. At the end of the exposure period, delay planting for at least one week for each 10 gallons of 1,3-D-containing product that you use per acre. Read the label to determine how long to aerate the treated area. Allow longer exposure and aeration periods when the soil is cold and wet. You can speed up aeration by cultivating the soil to the depth of the treatment zone.

## Detection

Detection devices are not normally used with soil fumigants such as 1,3-D.

## Disposal

Products that contain 1,3-D are sold in refillable containers. Return these containers to the distributors after use.

## Chloropicrin

Chloropicrin is a colorless, nonflammable, liquid fumigant. It is toxic to fungi, insects, mites and rodents in commodity storage sites. It will also control or suppress plant-parasitic nematodes and certain bacterial pathogens, soil fungi and soil-infesting insects. Chloropicrin is a

powerful tear gas. Its strong odor and irritating effects warn people of its presence.

You can use chloropicrin alone and with other fumigants. At a concentration of 2 percent or less, chloropicrin acts as a warning agent. At higher levels, it can enhance the activity of other fumigants.

*NOTE: Personal protective equipment (PPE) requirements and other use information differ depending on how you use chloropicrin, as a warning agent (low concentrations) or as a pesticide (higher concentrations). This manual covers information for chloropicrin when it is used as a pesticide only. This manual does not cover information for chloropicrin used as a warning agent. Always consult the label information before using any fumigant for any purpose.*

## Formulations

Chloropicrin products are nearly 100 percent pure. They come in a variety of containers and amounts:

- 1-pound bottles
- 3.5 pound and 13.5-pound plastic containers
- Nonpressurized cylinders that contain 2 to 70 pounds of product
- Pressurized cylinders that contain up to 375 pounds of product

## Uses

As a warning agent, chloropicrin can be used in dwellings (emptied of food products), empty structures (warehouses, grain bins, greenhouses, poultry houses, mushroom houses), and empty bags, boxes and crates. However, do not use chloropicrin near living plants or in dairy, cheese or meat factories. When used as a warning agent with sulfuryl fluoride in structural fumigations, chloropicrin is introduced before the actual fumigant is released. Methyl bromide structural fumigants are typically premixed formulations that contain chloropicrin as a warning agent.

As a pesticide, chloropicrin is limited to use in empty potato storage structures and the sub-floor aeration spaces below empty grain bins. Because it is nearly six times heavier than air, chloropicrin will sink down into the plenum area of bins with false floor aeration systems without the help of fans.

You can use chloropicrin to treat soil and agricultural fields. It will control or suppress soil insects and plant disease-causing organisms such as nematodes, bacteria and fungi.

### Chloropicrin at a glance:

#### Required clothing:

- Loose-fitting or well-ventilated shirt and long trousers.
- Shoes and socks.
- Full-face shield or safety glasses with brow and temple shields.
- Do not wear goggles.
- Do not wear jewelry.
- Do not wear gloves, rubber protective clothing or boots.
- Do not wear contact lenses.

#### Respiratory protection:

- Concentrations less than 0.1 ppm: no respiratory protection required.
- Concentrations greater than 0.1 ppm and less than 4 ppm: NIOSH-approved air-purifying respirator approved for organic vapors.
- Concentrations greater than 4 ppm or unknown concentrations: NIOSH-approved supplied-air respirator or SCBA.

#### Uses:

- What: Empty structures.
- Other: As a warning agent with other fumigants.
- What: Soil.
- Where: Agricultural fields and soil media in greenhouses or other enclosed structures.

Do not use chloropicrin alone or mixed with methyl bromide to treat foods, fresh fruits or vegetables. Products containing chloropicrin, even as a warning agent, are no longer labeled for direct application to stored grain.

## Application

When fumigating soil, apply chloropicrin through a closed system. Pressurize the system with dry, nonflammable compressed nitrogen gas at pressures between 30 and 120 psi. To be safe, use only equipment with parts that can withstand pressures above 150 psi. In addition, be sure your equipment is made of brass, copper, stainless steel, black carbon steel or polyethylene. Do not use aluminum, magnesium or any of their alloys (PVC, Neoprene, Buna-M, EDPM or rubber). Be sure all gaskets and threading sealants are made of compatible materials such as Teflon™.

Do not use chloropicrin when soil temperatures are below 50°F. Ideally, temperatures should be between 60°F and 85°F.

Chloropicrin moves through soil rapidly. For this reason, it is important to tarp treated soil to prevent premature loss of the fumigant from the soil.

To treat small areas or volumes of soil, potting mix or mushroom casing with chloropicrin, use a probe-type injection device. Release the product 6 to 8 inches below the soil surface in a grid pattern. Space your injection points 12 inches apart.

## Precautions

Handle chloropicrin in well-ventilated conditions with the applicator upwind. If the air concentration of chloropicrin exceeds 0.1 ppm, all persons in the exposed area must wear an air-purifying respirator approved for organic vapors. When treating soil inside a greenhouse or other enclosed structure, restrict entry for 48 hours after fumigation and until the concentration of chloropicrin is less than 0.1 ppm. If chloropicrin air concentrations are above 4 ppm or are unknown, all persons in the exposed area must wear a supplied-air respirator or an SCBA. If you detect a strong odor or your eyes start to tear, the mask is leaking. Leave the area and do not reenter unless you are wearing an SCBA. If necessary, supplement the SCBA with an air hose to provide air from an outside source.

However, you should only use this as an emergency backup supply in case the SCBA runs out of air. Regardless of the fumigant concentration in the work area, respiratory protection must be available at the fumigation site.

When handling and applying chloropicrin, be sure to wear a full-face shield or safety glasses with brow and temple shields. You should also wear loose-fitting, full-body clothing, shoes and socks. Do not wear goggles, gloves, rubber protective clothing or boots. If liquid chloropicrin splashes on your clothes, shoes or socks, remove them immediately. Place them outdoors until they aerate completely. Discard any absorbent items that have been drenched or heavily contaminated.

To be safe, use only fumigation equipment with parts that can withstand pressures above 500 psi. In addition, be sure your equipment is made of brass, copper, stainless steel, black carbon steel or polyethylene. Do not use galvanized pipe, aluminum, magnesium or any of their alloys (PVC, Neoprene, Buna-M, EDPM or rubber). Be sure all gaskets and threading sealants are made of compatible materials such as Teflon™. Fumigation “rigs” should include a filter to remove any particulates and a check valve to prevent backflow contamination of the pressurizing cylinder.

Chloropicrin is corrosive to most metals (for example, magnesium, aluminum, etc.). Take care to protect metal surfaces and equipment during treatment.

Chloropicrin should be stored in upright containers in a cool, dry, well-ventilated area under lock and key. Be sure to completely close the cylinder valve to reduce leaks and potential damage to metal. Do not store chloropicrin near people, animal feed, food or seed.

## Aeration

Long aeration periods may be needed to remove chloropicrin’s strong odor and “tear gas” effect. Follow the aeration procedures in the label information to determine your aeration time.

## Detection

You can use several devices to detect chloropicrin. Examples include color diffusion detector tubes and infrared detection systems (ambient air analyzers).

## Disposal

Dispose of excess product according to the label information. Return reusable cylinders to the manufacturer or distributor. Always triple-rinse plastic containers before recycling or reconditioning them. If you are not able to recycle a container, rinse and puncture it before disposing of it in a landfill, burning it or incinerating it.

## Controlled Atmospheres (CAs)

Controlled atmospheres (CAs) are low-oxygen mixtures of relatively inert gases such as nitrogen (N<sub>2</sub>) and carbon dioxide (CO<sub>2</sub>). CAs have three major advantages over other fumigants.

1. CAs leave no harmful residues on the treated commodities.
2. If a CA leaks from a treatment area, it will be diluted by normal air and reach nontoxic levels quickly.
3. CAs do not change the end-use processes (for example, baking, brewing, germination, etc.) or biochemical properties (for example, taste, odor, etc.) of commodities.

As a result, CAs have fewer government regulations than do other fumigants.

Unfortunately, CAs also have several disadvantages. The biggest problem is cost. Fumigation with CAs is usually more expensive than with other fumigants. It may not be cost-effective in many situations. Other disadvantages with CAs include the long exposure times and high concentrations required for effective control of many stored product pests. CAs also become much less effective at lower temperatures. Sixty degrees Fahrenheit is the lower limit for adequate pest control. Although CAs are often thought of as nontoxic, low-oxygen atmospheres are very hazardous to humans. They can cause unconsciousness and death quickly. Even when diluted with oxygen, CO<sub>2</sub> has some toxicity, as evidenced by an Occupational Safety and Health Administration (OSHA) worker exposure limit of 10,000 ppm (1%) during an 8-hour time-weighted average (TWA).

Because the atmospheric gas most commonly used as a fumigant is CO<sub>2</sub>, this manual discusses only CO<sub>2</sub> fumigation.

## Carbon Dioxide (CO<sub>2</sub>)

### Carbon dioxide at a glance:

#### Required clothing:

- None

#### Respiratory protection:

- Entry into any CO<sub>2</sub>-treated areas: NIOSH-approved supplied-air respirator or SCBA.

#### Uses:

- What: Raw agricultural commodities such as cereal grains.
- Where: Silos, trucks, trailers, bins, tanks and sealed railroad cars and ships.

CO<sub>2</sub> is a colorless, odorless and tasteless gas. It is about 1.5 heavier than air, and it is non-combustible. Although it is safer than other fumigants, a single breath of CO<sub>2</sub> in the high concentrations used for fumigation can cause a person to faint or fall. The main advantage of CO<sub>2</sub> is that it leaves no toxic residues and no odors or flavors. CO<sub>2</sub> also does not affect the germination of seeds.

## Formulations

CO<sub>2</sub> is commonly stored and transported as a liquid at 0°F and under a pressure of 300 psi. One pound of CO<sub>2</sub> produces 8.7 cubic feet of gas.

For most fumigants, you will need a large amount of CO<sub>2</sub>. Bulk containers range from 4 to 50 tons. These amounts are usually delivered by tanker truck and transferred to an on-site receiver. The liquid CO<sub>2</sub> is then vaporized and passed as a gas through the stored commodity. The CO<sub>2</sub> supplier is usually involved in the delivery and vaporization of CO<sub>2</sub>.

## Uses

You can also use CO<sub>2</sub> to treat raw commodities in bins, concrete soils, storage bins, tanks and railroad cars if you are able to seal the structures tightly enough to contain the fumigant. At high concentrations, CO<sub>2</sub> triggers increased respiration in insects. This can cause dehydration and death. The most effective concentration of CO<sub>2</sub> is about 60 percent. Lower than 60 percent, CO<sub>2</sub> levels are less effective.

Concentrations higher than 60 percent provide little or no added benefit.

Do not use CO<sub>2</sub> as a pesticide on fresh produce. Insecticidal concentrations are too high and may damage the produce.

CO<sub>2</sub> may also be useful for organic operations.

## Application

There are two methods available for treating stored products with CO<sub>2</sub>:

1. The top-down purge method.
2. The lift method.

The top-down purge method adds CO<sub>2</sub> at the top of a structure. The CO<sub>2</sub> displaces the air in the structure as it settles downward. The lift method adds CO<sub>2</sub> at the bottom of the structure. In this case, the CO<sub>2</sub> displaces the air in the structure as it moves upward.

The application method you choose will depend largely on the type of structure you intend to treat. Use the top-down purge method in concrete commodity elevators where you can place the injection hose in the top of a well-sealed tank. Bottom injection (the lift method) works best in stand-alone steel bins where major leaks occur at the top around eaves and hatches. In either application, you must vent the storage during the initial purge so that air pressure will allow the normal air to escape.

To determine when the purge is complete, measure CO<sub>2</sub> concentrations at the commodity surface or headspace (for the lift method) or at the base of the commodity mass or aeration floor (for the top-down purge method). When CO<sub>2</sub> levels reach 60 percent, seal the structure to prevent leaks and outside air from entering. Make additional injections of small amounts of CO<sub>2</sub> when concentrations within the commodity have dropped below 50 to 60 percent. Because CO<sub>2</sub> is heavier than air, it can settle into the bottom of the storage. You can use recirculation systems to improve the efficiency of CO<sub>2</sub> fumigation.

CO<sub>2</sub> application in commodity storages requires a pressure regulator to drop pressures from 300 psi in storage tanks to 10 to 40 psi at the injection hose. Use a flowmeter and globe valve to measure and set the flow of CO<sub>2</sub> to the desired rate, usually measured in pounds per hour. You will also need a vaporizer to speed the conversion of CO<sub>2</sub> from liquid to gas.

The effectiveness of CO<sub>2</sub> depends on several factors. Principal among these are commodity temperature and the insect species you target. Adjust the duration of treatment accordingly. If commodity temperatures are less than 60°F, CO<sub>2</sub> fumigation is usually not effective because fumigation times become extremely long. As commodity temperatures increase, however, fumigation time drops. For example, when grain temperatures are near 80°F, most insects that live outside of the grain kernel will die if they are exposed to CO<sub>2</sub> for 4 to 5 days. Internally developing insects, such as weevils, require longer exposure periods of 10 to 14 days.

*NOTE: While insect eggs are often resistant to chemical fumigants, they are more susceptible to CO<sub>2</sub> and other CAs.*

## Precautions

While CO<sub>2</sub> leaves no toxic residues in treated commodities, it is poisonous at high concentrations in enclosed spaces. The concentration of CO<sub>2</sub> in the atmosphere is about 0.03 percent. The threshold limit value (TLV) for CO<sub>2</sub> exposure is 1.0 percent. When concentrations of CO<sub>2</sub> reach 2 percent, human breathing rates increase by 50 percent above normal. At 5 percent CO<sub>2</sub>, human breathing is three times more rapid than normal. Such levels can cause strain, fatigue and exhaustion. High concentrations of CO<sub>2</sub> not only reduce available oxygen, they also trigger additional respiratory stress.

Always monitor CO<sub>2</sub> concentrations when applicators enter a fumigated structure. Also check enclosed work areas adjacent to the structure.

Gas mask/canister respirators do not provide protection in high-CO<sub>2</sub>, low-oxygen atmospheres. Although the canister may absorb the fumigant, it cannot supply the necessary oxygen. Only an SCBA or supplied-air respirator provides adequate protection.

As a rule, do not enter an area undergoing fumigation with CO<sub>2</sub> except under emergency conditions. Then, you must wear an SCBA or supplied-air respirator.

## Aeration

Structures fumigated with CO<sub>2</sub> must be aerated before unprotected workers may enter. CO<sub>2</sub> is known to sorb into commodities and may desorb slowly. Read the label information for specific aeration instructions.

## Detection

Check CO<sub>2</sub> concentrations throughout the treatment process. Monitor low concentrations of CO<sub>2</sub> to provide information for worker safety. Monitor high concentrations of CO<sub>2</sub> to determine the need for continued injection of CO<sub>2</sub> into the structure. Use vacuum pumps and tubing to draw gas samples during fumigation. Test these samples with gas detector tubes. Use separate tubes to detect low and high levels of CO<sub>2</sub>. Thermal conductivity sensors capable of measuring a range of CO<sub>2</sub> concentrations are also available.

## Disposal

Dispose of CO<sub>2</sub> containers according to the label information.

## Dazomet

Dazomet is formulated as a nonflammable white or yellowish solid with a characteristic odor. If it contacts damp soils, dazomet decomposes into the active ingredient methyl isothiocyanate (MITC). MITC is toxic to many organisms, including aquatic organisms and humans. Dazomet is insoluble in water.

### Dazomet at a glance:

#### Required clothing:

- Coveralls over a short-sleeved shirt and short pants.
- Chemical-resistant footwear plus socks.
- Waterproof gloves.

#### Respiratory protection:

- A NIOSH-approved air-purifying respirator is required for application in greenhouses or other enclosed areas. A NIOSH-approved half-face respirator may be worn if face-sealing goggles are used.

#### Uses:

- What: Soil and compost.
- Where: Compost piles, golf greens/tees, fairways, potting soils, seed and propagating beds, soil heaps and piles, soil media, ornamental beds and soil media in greenhouses or other enclosed structures.

## Formulations

Currently, dazomet is sold only as a granular product containing 99 percent active ingredient and 1 percent inert ingredients.

## Uses

As a soil fumigant, dazomet will control most weeds, nematodes and plant diseases caused by soil-borne pathogens. However, it is not registered for the control of soil insects. You can use dazomet to fumigate soil for interplanting within existing orchards, berry fields and similar areas. It will also kill grasses and weeds in lawn and turf areas before renovation.

## Application

There are several ways to apply dazomet. These include:

- Incorporation With Tarping – incorporating dazomet into the soil and then tarping the soil to seal in the fumigant
- Incorporation Without Tarping – incorporating dazomet into the soil and then rolling and irrigating the soil to seal in the fumigant
- Topical Application With Irrigation – applying dazomet to the top of the soil and then using irrigation to seal in the fumigant

### Incorporation With Tarping

To apply dazomet via the “Incorporation with Tarping” method, use scoops, shakers, drop-type fertilizer spreaders or other suitable equipment to spread the product as evenly as possible. Do not use rotary spreaders. Immediately after spreading, incorporate the granules uniformly to a 4-inch depth using a C-shaped tine rototiller or spading machine. After incorporation, seal the treated soil by covering it with a polyethylene sheet.

Maintain soil moisture at 50 percent of field capacity for 5 to 14 days before treatment and during treatment. In addition, be sure soil temperatures are between 43°F to 68°F. Record the soil temperature in your treatment log.

Unfortunately, tarping soils can be expensive. For this reason, the “Incorporation with Tarping” method is usually reserved for smaller areas.

## **Incorporation Without Tarping**

For large areas, the labor and disposal costs associated with tarping may be undesirable. In these cases, you can seal in an incorporated fumigant by compacting and irrigating the soil. First, apply and incorporate dazomet as described in the “Incorporation with Tarping” section. Then, instead of covering the soil with a tarp, compact the soil surface with a roller and add moisture to form a crust on the soil surface. Keep the treated soil wet but not waterlogged for 72 hours after treatment. If treated soils are untarped, moisten them frequently for 5 to 7 days after treatment. This will minimize cracking of the soil surface. Cracks may allow fumigant to escape before the target pests are completely controlled.

## **Topical Application With Irrigation**

Topical application with irrigation works best in areas you do not want to till, such as golf greens, tees and fairways. This method uses water instead of tillage to draw dazomet into the soil. First, prepare the target area. If weeds are present, apply a nonselective herbicide. Then, mow the area close to the ground and remove as much debris as possible. Apply dazomet with a drop spreader at the label rate. Irrigate the treated area. Keep the soil surface wet but not waterlogged for at least 72 hours after application. Then moisten the treated area frequently for 5 to 7 days after treatment. Conduct a seed germination test with lettuce seed or cress seed before planting, seeding or sowing. See Unit 5 for more information about this test.

For all application methods, waiting periods between application of dazomet and planting or seeding depend on soil temperature and moisture. Higher moisture levels and lower soil temperatures usually require a longer wait.

Thoroughly clean your application equipment with a strong detergent or a commercial sprayer cleaner before and after treatment.

## **Precautions**

Do not apply dazomet when air temperatures are over 103°F or when wind might blow product granules away from the target area. Keep the product 3 to 4 feet from growing plants and no closer than the dripline of trees and large shrubs. Do not apply dazomet to any area where surface water is present or likely to occur, or any area that is subject to runoff. After treating orchards, berry fields and similar areas, do not harvest produce for one full year after application.

Notify workers verbally and by posting fumigant warning signs outside entrances to the treated area. Do not drink alcoholic beverages before, during or after working with dazomet.

Fumigation with dazomet can reduce the nitrification of fertilizers. You can decrease this risk by using fertilizers that contain a high percentage of nitrogen. It also helps to fumigate several months before planting.

Do not apply manures, fertilizers or lime with dazomet.

## **Aeration**

Aerate treated soil no sooner than 5 to 7 days after application. At that time, loosen treated soil thoroughly to the depth of incorporation by tilling it with a disk, power tiller or hand implement. To avoid crop injury, be sure that all dazomet residues are gone from the soil before planting or seeding. Keep in mind that soils with high levels of organic matter will take longer to aerate. Read the label information to determine how long to wait between treatment and planting, seeding or transplanting. You can also conduct a seed germination test with lettuce seed or cress seed that will indicate whether treated soil is safe for planting. See Unit 5 for more information about this test.

## **Detection**

For applying dazomet outdoors, detection devices are not normally used. For treatments in enclosed structures, read the label to determine what reentry standards to use.

## **Disposal**

Dispose of excess dazomet wastes according to the label information. Always triple-rinse plastic containers before recycling them. If you are not able to recycle a container, rinse and puncture it before disposing of it in a landfill, burning it or incinerating it.

## **Metam Sodium**

Metam sodium is a nonflammable, amber to yellow-green, water-soluble liquid. It has a characteristic odor of rotten eggs. Metam sodium readily decomposes into the active ingredient MITC. Metam sodium is toxic to many organisms, including aquatic organisms and humans.

## Formulations

Metam sodium is available as a 42 percent liquid solution. It is available in a variety of containers and amounts, including:

- 55-gallon drums
- Mini-bulk containers, 250 to 300 gallons
- Trailerloads, 4,500 gallons
- Railcars, 18,500 gallons

## Uses

As a soil fumigant, metam sodium will control most weeds, nematodes, and plant diseases caused by soil-borne pathogens. Metam sodium is registered for use on all crops for the treatment of soil or agricultural fields. It will also kill grasses and weeds in commercial sod, turf and ornamental flower farms before seeding or sprigging. Read the label information to be sure that metam sodium will control the pest or disease you wish to target.

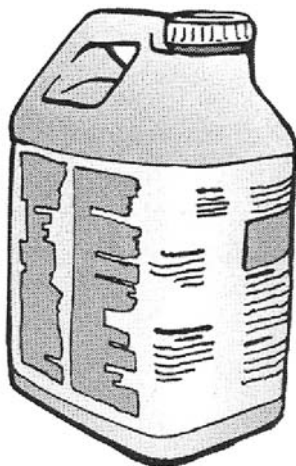

Metam sodium container

## Application

There are many ways to apply metam sodium. The most common methods used are soil injection, chemigation and rotary tiller or power mulcher application.

### Soil Injection

This method uses injectors (shanks, blades, fertilizer wheels, plows, etc.) to apply metam sodium below the soil surface. A bed shaper, roller press wheel or similar device follows behind the injection equipment to immediately seal the fumigant into the soil. You can also seal the injection zone by covering it with an adequate amount of soil. Light watering (1/2 inch of water is usually best) or tarping after rolling also helps to reduce gas escape.

### Chemigation

Chemigation applies pesticide through an irrigation system. The two most common types

## Metam sodium at a glance:

### Required clothing:

#### Outside an enclosed tractor cab when performing direct contact tasks:

- Coveralls over a long-sleeved shirt and long pants.
- Chemical-resistant footwear plus socks.
- Face-sealing goggles, unless a full-face respirator is worn.
- Chemical-resistant headgear for overhead exposure.
- Chemical-resistant apron.

#### Inside an enclosed tractor cab:

- Coveralls.
- Shoes and socks.
- Additional clothing for direct contact activities must be immediately available and must be worn if the handler leaves the enclosed cab to perform any direct contact activity.

#### Early entry of the treated area:

- Coveralls over a long-sleeved shirt and long pants.
- Waterproof or chemical-resistant gloves.
- Chemical-resistant footwear plus socks.
- Face-sealing goggles, unless a full-face respirator is worn.

### Respiratory protection:

#### Outside an enclosed tractor cab when performing direct contact tasks:

- A NIOSH-approved air-purifying respirator with a canister approved for pesticides or an organic-vapor-removing cartridge with a prefilter approved for pesticides.

#### Inside an enclosed tractor cab:

- A NIOSH-approved air-purifying respirator with a canister approved for pesticides or an organic-vapor removing cartridge with a prefilter approved for pesticides.

#### Early entry of the treated area:

- If a pungent, rotten-egg odor can be detected, a NIOSH-approved air-purifying respirator must be worn with either a canister approved for pesticides or an organic-vapor-removing cartridge with a prefilter approved for pesticides.

### Uses:

- What: Soil.
- Where: Agricultural fields. Not for use in greenhouses or other enclosed areas.



of irrigation used to apply metam sodium are sprinkler irrigation and drip irrigation.

Sprinkler chemigation requires 1 to 1 1/2 inches of water. Start by pre-irrigating the field five to seven days before application to stimulate biological activity. Then, apply metam sodium in a minimum of 1 acre-inch of water. Continuously meter the fumigant into the irrigation system throughout the application period. Be sure to apply a 1/2 inch water seal. If the soil surface dries quickly, reseal it with 1/2 inch of water once the next day. Use only sprinkler systems that produce large water droplets. This will reduce evaporation and drift. Operate the system at the lowest pressure possible.

When applying metam sodium with drip irrigation, first pre-irrigate the field as described for sprinkler irrigation. Check the drip tape for uniform distribution. Then, apply the fumigant using enough water to thoroughly wet the treatment zone. Inject metam sodium continuously into the drip line as close as possible to the treatment area. You may need two or more lines per bed to ensure full coverage.

### **Rotary Tiller or Power Mulcher Application**

This method sprays dilute metam sodium in front of a tiller or mulcher, which incorporates the fumigant into the soil. A bed shaper, roller press wheel or similar device follows behind the tiller or mulcher to immediately seal the fumigant into the soil. You can also seal the treatment zone by covering it with an adequate amount of soil.

Immediately after all methods of application, you must seal the soil in order to retain the fumigant. Several options are available, including:

- Water sealing with irrigation systems (1/2 inch of water is usually recommended)
- Tarping the soil
- Compacting the soil with rollers or similar devices
- Covering the treatment zone with soil that has not been affected by the application

Consult the label information for specific sealing recommendations that apply to your crop.

In lighter soils, you can often apply metam sodium 14 days before planting. In heavier soils with high levels of organic matter, however, you

will need to wait 21 days or longer after application before planting a new crop. This will allow the product to dissipate from the treated soil.

When applying metam sodium, soil moisture should usually be between 50 percent to 80 percent field capacity down to 24 inches. Proper moisture is essential to stimulate pest activity before and during treatment. It will also help ensure the distribution and retention of the fumigant within the treatment zone. Soil temperatures must range between 40°F to 90°F. Metam sodium works best at 60°F to 90°F. For more specific information, read the label information for the method you intend to use and crop(s) you intend to target.

In most cases, air temperatures should be below 90°F (mandatory for application by chemigation) and wind speeds should be no more than 7 mph. Early mornings tend to offer the best combination of weather conditions for application. Avoid applying metam sodium when ground fog is present.

Metam sodium moves differently in the soil than many other fumigants. Specifically, it does not travel far from the point of injection. For example, when you apply metam sodium by shank injection, it is likely to stay within 3 inches of the point of injection. More limited movement means that metam sodium is more likely to remain within the treatment zone for a longer period. This can increase the exposure period and improve pest control. However, you must adjust your equipment to compensate for the slower movement. The best way to do this is to increase the total number of application points. For example, when using soil injection to apply metam sodium, space the shanks no more than 6 inches apart, horizontally and vertically. Double drip lines for wide-bed drip irrigation can be helpful for the same reason.

### **Precautions**

Metam sodium products should only be used to treat soil. Do not use them in confined spaces such as greenhouses or in areas where fumes can enter nearby dwellings. Be sure to leave a 3-foot buffer between treated soil and desirable plants, shrubs and trees. Always use metam sodium products promptly after mixing them with water. Do not store diluted product or allow a solution that contains metam sodium to stand overnight.

Do not apply metam sodium with equipment that contains fittings that are zinc coated, galvanized or made from copper or brass. Metam sodium is corrosive to these metals as well as to aluminum. It may also soften or discolor iron. Be sure that pump impellers are not made from brass or galvanized material. Try to keep hose lengths on application equipment as short as practical and pointed away from the operator. Use a dry-disconnect transfer system rather than compressed air to transfer product.

**Do not apply** metam sodium through irrigation systems that are connected to public water systems.

## Aeration

When using tarps to seal an area treated with metam sodium, leave the tarps in place for at least 48 hours. Five to seven days after application, begin frequent shallow cultivation to aid aeration. Repeat cultivation as necessary, but be careful not to introduce untreated soil from below or around the treated area.

Wait at least 21 days between fumigation and planting. If you think the treated soil contains metam sodium residues after 14 to 21 days, conduct a lettuce seed or transplant test. See Unit 5 for more information about these tests.

## Detection

Since metam sodium is only used outdoors, detection devices are rarely used.

## Disposal

Read the label information to determine how to dispose of metam sodium wastes properly. Always triple-rinse (or equivalent) containers and bulk storage tanks before disposing of, recycling or reconditioning them.

For more information about metam sodium, contact the Metam Sodium Task Force. Your Extension agent or product manufacturer can help you get in touch with this organization.

## Methyl Bromide

Methyl bromide is a colorless gas at standard temperatures and pressures. At normal concentrations, it is odorless, tasteless and has no irritating qualities to indicate its

presence. However, at concentrations higher than those normally used in fumigation, methyl bromide has a sickly sweet odor. Methyl bromide is toxic to all stages of insect life, as well as to many microorganisms and weeds. It is usually stored under moderate pressures so that it can be handled as a liquefied gas.

When injected into soil, methyl bromide vapor diffuses through the soil and dissolves in soil water, where it attacks target pests. When used above ground, methyl bromide gas is 3.3 times heavier than air and tends to stratify, settling out in low places. In such cases, you will need fans to ensure thorough mixing of the gas with air. With fans, methyl bromide penetrates most commodities well.

### EPA Alert

At the time of this printing, methyl bromide is believed to contribute to the depletion of the earth's ozone layer. For this reason, the EPA has initiated action under the Clean Air Act to phase out the production and use of this fumigant. A 70 percent reduction in production was mandated by January 1, 2003. The complete phaseout of production was scheduled for January 1, 2005. The Environmental Protection Agency (EPA) is amending the regulations governing the phaseout of methyl bromide (MeBr) to allow for exempted production and import beyond the phaseout date of January 1, 2005, for critical uses and to address sales of pre-January 1, 2005 stocks of methyl bromide for critical uses. This rule makes approximately 8,942 metric tons of methyl bromide available for critical uses in 2005, which is 35 percent of the U.S. methyl bromide 1991 consumption baseline. The 1991 consumption baseline was established in the 1993 rulemaking, to cap and phase out methyl bromide production and import. An additional 2.5 percent of baseline was recently authorized for 2005 critical uses by the Parties to the Montreal Protocol at their meeting on November 26, 2004. EPA is beginning the notice-and-comment rulemaking process on the supplemental amounts to make them available for critical uses as quickly as possible. It is your responsibility to keep up-to-date on any changes that affect the legal use of products you intend to use.

## Methyl bromide at a glance:

### Required clothing:

- Loose-fitting or well-ventilated long-sleeved shirt and long pants
- Shoes and socks
- Full-face shield or safety glasses with brow and temple shields when performing direct contact tasks
  - Do not wear goggles.
  - Do not wear jewelry.
  - Do not wear gloves, chemical protective clothing or rubber boots.
  - Do not wear contact lenses.

### Respiratory protection:

- Air concentrations less than 5 ppm: no respiratory protection required
- Air concentrations greater than 5 ppm or when air concentrations are unknown: NIOSH-approved SCBA or combination supplied-air/SCBA respirator required

### Uses:

- What: Soil and potting mixes, baled cotton and tobacco, feed and other raw agricultural commodities, forest and plant products, beehives and beekeeping equipment and miscellaneous nonfood cargo. Entire structures and dwellings, bags, boxes, crates (empty), furniture, lumber and wood products
- Where: Structures that contain commodities: warehouses, grain elevators and other buildings storing raw products. Chambers and vaults: vacuum chambers, tarpaulin fumigation, box-cars, trucks, vans, ships and trailers. Agricultural areas: outdoor seedbeds, fields and orchards. Other: piles of soil or planting mixes in greenhouses or other enclosed structures. Structures – warehouses, grain elevators, food processing plants, restaurants and other empty buildings.

## Formulations

For commodity fumigation, you can use formulations that contain 100 percent methyl bromide. When treating soil, however, you must use formulations that contain 2 percent or more of chloropicrin. Chloropicrin improves plant disease control. Chloropicrin also serves as a warning agent for the otherwise undetectable methyl bromide.

Methyl bromide is available as a compressed liquid in 1 1/2-pound cans or in cylinders that contain from 50 to 1,500 pounds.

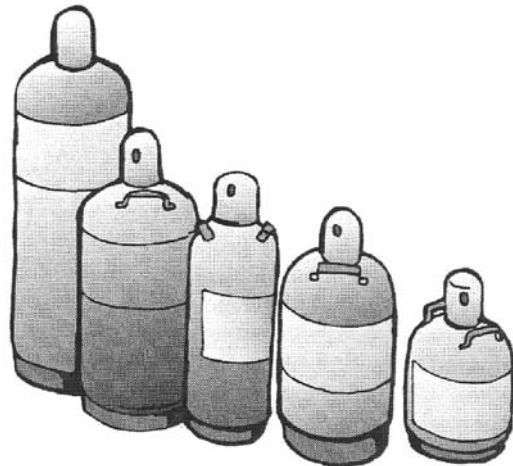

Cylinders of Methyl Bromide

## Uses

Use methyl bromide to control pests in processed food or feed. There are established tolerances for methyl bromide residues on many commodities. Pure methyl bromide is not labeled for use in empty structures. It is strictly for the treatment of raw or processed commodities and some nonfood products. When mixed with chloropicrin, do not use methyl bromide on processed foods; in dairy, cheese or meat plants; or where there are living plants. Instead, apply these mixtures to control termites and powder-post beetles. You can also use them to treat empty grain bins and warehouses.

There are several materials that should not be exposed to methyl bromide. Some react with the gas and create long-lasting odor problems. Others may be damaged by the gas. Do not use methyl bromide to treat the following items:

- Iodized salt
- Full fat soya flour

- Items that may contain reactive sulfur compounds such as some soap powders, some baking sodas, and some salt blocks used for cattle licks
- Sponge rubber
- Foam rubber, as in rug padding, cushions, and mattresses
- Reclaimed rubber, such as rubber stamps
- Furs
- Horsehair
- Pillows (especially feather pillows)
- Leather goods (particularly white kid or any other leather goods tanned with sulfur processes)
- Woolens
- Viscose rayons (rayons produced or manufactured by a process that uses carbon bisulfide)
- Paper (especially silver polishing paper and writing paper cured by the sulfide process)
- Photographic materials used in darkrooms
- Cinder blocks

It is also important to remove all charcoal products before fumigating with methyl bromide. Charcoal can absorb methyl bromide, reducing its effectiveness.

Methyl bromide is most often formulated with chloropicrin for use in soil fumigation. It will control plant-parasitic nematodes, soil microorganisms that cause important root and stem diseases, many broadleaf weeds and grasses and some soil insects. These methyl bromide-chloropicrin mixtures often provide better control of target pests compared to methyl bromide alone. Beware, however, chloropicrin is not safe for many items that methyl bromide, by itself, can be used to treat. For example, when mixed with chloropicrin, do not use methyl bromide:

- On or around food
- Where there are living plants

Always read the label information of both fumigations before using the mixture for any purpose.

In addition to soil pests, you can also use methyl bromide to control pests in raw foods (including grains, fruits and vegetables), animal feed, cotton and tobacco. There are established tolerances for methyl bromide residues on many commodities.

Methyl bromide is registered for fumigation of plants, bulbs, corms, tubers, rhizomes and

roots. These types of applications are usually reserved for quarantine situations. However, plant materials are, in general, intolerant of this product. Read and follow the label information carefully. You may also want to contact the manufacturer for specific instructions when fumigating living plants. Also remember that chloropicrin is poisonous to plants. Never use methyl bromide containing chloropicrin on live plants.

## Application

### Soil Fumigation (formulations that contain at least 2 percent chloropicrin)

Small cans (1 1/2 pounds) of methyl bromide that contain at least 2 percent of chloropicrin are ideal for tarpaulin jobs that treat small areas. These applications may include outdoor plant or seedbeds, piles of manure, decomposed compost or potting mix, ant colonies in soil or small quantities of a commodity.

When using cans to treat small, tarped areas you must use evaporation pans or combination opener-evaporating pans.

Evaporation pans are plastic or metal (not aluminum) shallow pans used to hold liquid methyl bromide during application. To use them, place the pans under the tarp. Anchor one end of a polyethylene tube in each evaporation pan with tape or a suitable weight. Attach the other end of each tube to a methyl bromide container located outside the tarp. The polyethylene tube directs the liquid methyl bromide from the cans to the pans. The liquid fumigant will volatilize in the pans.

Combination opener-evaporating pans, such as a Simplex tray, allow you to place both the pan and the fumigant container under the tarp. Each trap can hold several cans of methyl bromide. Spikes on the bottom of the tray will puncture the bottom of the cans. Once punctured, the liquid methyl bromide flows into the pan where it evaporates. You do not need tubing with the combination opener-evaporating pans.

For most soil treatments and for larger amounts of commodities, you will need to use cylinders (50 to 1,500 pounds) of methyl bromide.

When treating soil with cylinders of methyl bromide, you will often use the injection method. This involves application equipment that is mounted on a tractor. A cylinder of nitrogen gas

pressurizes the equipment. This helps it to deliver a consistent quantity of fumigant to the soil. To adjust the amount of fumigant you apply, use a flowmeter or a constant pressure system combined with orifice plates. Liquid methyl bromide/chloropicrin flows through a tube from each cylinder to shank/chisel type injectors. These injectors place the fumigant 6 to 8 inches below the soil surface. Once in the soil, the fumigant changes into a gas.

You can apply methyl bromide to soil in many ways, including:

- As a broadcast treatment to entire fields
- As a row or strip treatment
- As an individual treatment to sites where single trees will be replanted.

In many of these cases, you will have to cover the treated area with a tarp as you apply the fumigant. Follow the label information for each type of application method.

### **Commodity Fumigation (formulations of 100 percent methyl bromide)**

To treat raw products with methyl bromide, first seal the space in which the commodity is stored. Then release the fumigant in one of several ways depending on the location of the commodity. If the commodity is in a chamber or vault, introduce methyl bromide by:

- Releasing it in front of a blower or fan
- Passing it through a vaporizer
- Allowing it to evaporate from a shallow pan

Keep all controls outside the treatment chamber.

For vacuum fumigation, release methyl bromide through an appropriate heating unit. This will ensure vaporization of the product as it travels to the treatment chamber. When treating commodities in vehicles, containers and buildings use “shooting lines” (polyethylene tubing or other compatible tubing) to introduce methyl bromide.

Since methyl bromide is 3.3 times heavier than air, it can settle in low places. This can cause stratification during commodity fumigation. Use nonsparking fans to speed up and maintain uniform gas distribution.

Methyl bromide works quickly. Exposure times of 24 hours or less are normal. Read the label to find out what the required exposure time is for your application.

## **Precautions**

If the concentration of methyl bromide is unknown or exceeds 5 ppm, each person in the exposed area must wear an SCBA or combination supplied-air/SCBA respirator. When applying formulations that contain chloropicrin, you must wear an SCBA if the air concentration of chloropicrin is greater than 0.1 percent. Regardless of the fumigant concentration, respiratory protection must be available at the treatment site in case it is needed.

If the cylinders are outdoors, you do not need to wear a respirator while introducing methyl bromide unless a leak develops and the air concentration of methyl bromide is greater than 5 ppm. Check the label for specific requirements. Always have an SCBA ready and available.

Never transport methyl bromide containers in the passenger section or trunk of a vehicle.

Do not wear jewelry, gloves, goggles, tight clothing, a chemical protective suit or rubber boots when using methyl bromide. The gas can be trapped inside your clothes and cause skin damage. If liquid methyl bromide splashes on your clothes, shoes or socks, remove them immediately. Place them outdoors until they aerate completely. Discard any absorbent items that have been drenched or heavily contaminated. Leather will absorb methyl bromide and may aerate slowly.

Check soil fumigation equipment, filters, tubes or hoses, chisels and orifice plates for debris and obstructions before use. Be sure the entire system is pressurized with nitrogen. Use a soap solution to check for leaks. Do not use equipment that contains aluminum, magnesium, zinc and alkali metals to apply methyl bromide. Contact with these metals many cause corrosion and release of toxic gases, as well as fire and explosion hazards. Make sure that all fittings are made of brass or stainless steel and that hoses are made of Teflon™ or Teflon™-lined steel braid. Do not use galvanized pipe. Be sure that soil fumigation “rigs” include:

- A filter to remove debris from the methyl bromide
- A check valve to prevent backflow of the product into the nitrogen cylinder that pressurizes the system
- Components with a pressure rating of at least 500 psi

Nitrogen cylinders are kept at a pressure of about 2,000 psi. Be sure to check and maintain regulators that reduce the pressure during application on a regular basis. If a regulator fails, the system may overpressurize. This could cause the methyl bromide cylinder to rupture.

Do not use methyl bromide to control insects in/on a commodity when the temperature of the commodity or the space is less than 40°F. Do not use methyl bromide to control rodents or other warm-blooded pests when temperatures are below 20°F. Heat the fumigant when temperatures are below 60°F.

Methyl bromide is not a fire hazard. In fact, it once was an ingredient in fire extinguishers. Still, you must extinguish all open flames and pilot lights before using methyl bromide. It produces corrosive acid when it reacts with moisture near a heat source. In addition, while methyl bromide does not corrode most metals, it can react with aluminum or magnesium in the absence of oxygen to form an explosive mixture. Therefore, never connect aluminum or magnesium tubing to a methyl bromide cylinder. Be sure neither metal is present during vacuum fumigation with methyl bromide.

There are several materials that should not be exposed to methyl bromide. Some react with the gas and create long-lasting odor problems. Others may be damaged by the gas. Be sure to read the label information before treating any item with methyl bromide.

## **Aeration**

After fumigating soil with methyl bromide, delay use of the treated area according to label directions. This will allow the product to break down in the soil and escape into the atmosphere. If you tarp the soil, begin aeration by breaking the seals around the edges of the cover. Cultivate the soil, usually no sooner than 7 to 10 days after application, to speed the aeration process.

To aerate fumigated commodities, open doors and windows and/or remove the tarp to allow air exchange. You may use fans to speed the exchange of air. During fumigation with methyl bromide, commodities may contain inorganic bromide residues. Aeration does not remove these compounds. After repeated treatments, residues may exceed legal tolerances. The Food and Drug Administration (FDA) may seize

the product. If this occurs, the last fumigator may be held responsible. Always check past fumigation records before treating any product. Be sure your treatment will not increase residue levels past legal limits. For help, contact the fumigant manufacturer.

## **Detection**

You can measure methyl bromide concentrations in air with halide gas detectors, color diffusion detector tubes and thermal conductivity analyzers (TCAs) such as the Fumiscope®. More sophisticated detection systems now include infrared, photoionization, flame ionization and electron capture detectors. Always consider the sensitivity of the detection device when making your selection. For example, the halide gas detector and Fumiscope® only provide an indication of methyl bromide presence. They do not indicate concentration. Use these devices to detect leaks. Halide detectors and TCAs do not read low enough to detect gas levels for reentry purposes. To check fumigant levels before reentry, use color diffusion detector tubes.

Always read the label information to be sure you select the appropriate detection device. Follow all detection device instructions.

Detection devices are rarely used for outdoor soil applications of methyl bromide.

## **Disposal**

Dispose of methyl bromide containers according to label directions. Return empty or partial cylinders to the manufacturer. Cans are not returnable. Aerate empty cans in a well-ventilated, secure location for 12 hours before disposal. If local authorities allow, you may be able to recycle the cans. Otherwise, dispose of them according to local regulations.

## **Phosphine**

### **Aluminum Phosphide and Magnesium Phosphide**

There are two main types of phosphine fumigants: aluminum phosphide and magnesium phosphide. These “metal phosphides” are formulated as solids that react with moisture in the air to produce hydrogen phosphide (phosphine gas). Phosphine also comes as a bottled product (phosphine dissolved in liquid carbon dioxide).

## Aluminum phosphide and magnesium phosphide at a glance (also called hydrogen phosphide and $\text{PH}_3$ ):

### Required clothing:

- Dry cotton gloves if you contact the pellets, tablets or dust

### Respiratory protection:

- Respiratory protection is required if exposure is likely to exceed the 8-hour TWA of 0.3 ppm during application, or is above 0.3 ppm at any time after application is complete
- Concentrations less than 0.3 ppm: no respiratory protection required
- Concentrations 0.3 to 15 ppm: NIOSH-approved full-face gas mask and hydrogen phosphide canister
- Concentrations 15.1 to 1,500 ppm: NIOSH-approved full-face gas mask and hydrogen phosphide canister for escape only
- Concentrations greater than 15 ppm or when concentrations are unknown: NIOSH-approved SCBA or supplied-air respirator

### Uses:

- What: Raw agricultural commodities such as grains, nuts, seeds, cotton, wool and tobacco. Animal feeds and feed ingredients, processed foods and non-food items
- Where: Boxcars, containers, ships and other transport vehicles, bins, silos, barges, under tarpaulins, in small sealable structures and enclosures, mills, food processing plants, and warehouses.

Phosphine gas is colorless and highly toxic to all stages of insect and animal life. It has a distinct garlic or carbide odor that is readily detectable at levels below worker protection limits (0.3 ppm). The odor is due to an impurity rather than the phosphine gas itself. However, odor is not a reliable indicator of the presence or absence of phosphine. This is especially true when phosphine has been in contact with a commodity for a considerable length of time.

## Formulations

Both aluminum phosphide and magnesium phosphide fumigants are available in a number of formulations. These include pellets, tablets, Prepacs, bags and plates. Since metal phosphide fumigants react readily with moisture, they must be packaged in gastight containers. Phosphine can also be applied from cylinders that contain phosphine in liquid carbon dioxide.

Most aluminum phosphide formulations yield about 1/3 of their weight in phosphine. Aluminum phosphide is available in 0.6-gram pellets and 1.0-gram tablets.

Magnesium phosphide comes as Prepacs and in polyethylene plates and strips.

**Pellets:** Pellets weigh 0.6 gram. They yield 1/3 (0.2 gram) of their weight in phosphine. They are available in resealable flasks.

**Tablets:** Each tablet weighs 3 grams and releases 1 gram of phosphine. Tablets are available in resealable flasks. Tablets are also used in Prepacs and Prepac Ropes.

**Packaged Fumigants:** Packaged fumigants are available in several forms. These include bags, Prepacs and plates. In all cases, the metal phosphide is encased in a gas-permeable material, which is overpacked in gastight containers. Bags that contain a powdered aluminum phosphide formulation are also available. Each bag will release 11 grams of phosphine. Many of these packaged fumigants are not resealable. Once opened, you must use the entire contents.

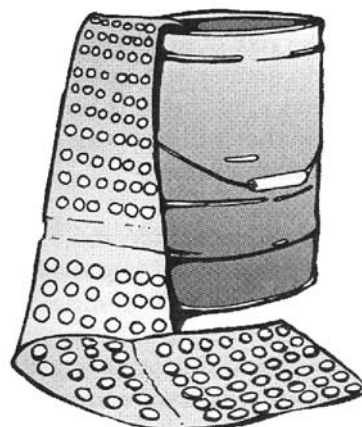

Phosphine Prepacs

## Uses

Use metal phosphides to treat raw agricultural commodities such as grains, nuts, seeds, cotton, wool and tobacco. You can use metal phosphides to treat spaces and commodities and to control certain burrowing pests. Commodities treated with phosphine include processed foods, nonfood items, animal feed and feed ingredients.

Aluminum phosphide is the main form used to treat raw commodities. Magnesium phosphide is more reactive than aluminum phosphide. It is preferred when rapid release is desired and when treatment is performed at lower temperatures and humidities.

## Application

One advantage of metal phosphide products is that they are easy to use. Start by calculating the cubic volume of the space you intend to treat. (See Appendix B for information on calculating volume.) Then, count out the required number of pellets, tablets, plates, Prepacs or bags. Always wear gloves when handling phosphide tablets or pellets. Packaged metal phosphides such as bags and Prepacs do not require gloves. Place the pellets, tablets or bags onto a tray or sheet of cardboard. Slip the tray under the fumigation tarp or inside the fumigation chamber or structure. The moisture in the air will liberate phosphine in about one day, depending on the temperature and humidity.

To treat raw commodities such as grain, scatter phosphide tablets or pellets over the surface of the grain. Spread the fumigant evenly over the surface. You can also use a probe to insert the tablets or pellets directly into the grain stream as the grain is moved into storage or as it is “turned” (recirculated).

Fumigation with phosphine takes time. Buildup of the fumigant is slow. It may take 12 to 48 hours to reach the desired concentration of gas. If the atmosphere or commodity is very dry, the process may take even longer. In areas where the relative humidity is low, you can increase the speed of gas liberation by placing a pan of water under the fumigation tarp. You can also spray water onto the floor or dirt. Be very careful. Do not allow any water to contact the phosphine. An explosive mixture may result.

Normal exposure periods can take 3 to 5 days. If gas concentrations are lower than required after 72 hours, extend the fumigation period.

Magnesium phosphide releases phosphine faster than does aluminum phosphide. Therefore, you are more likely to need respiratory protection when applying magnesium phosphide.

Phosphine is not effective at temperatures below 40°F. Be sure to keep aluminum phosphide and magnesium phosphide products dry during storage. Since magnesium phosphide is more reactive than aluminum phosphide, it is usually recommended for fumigation in cool and/or dry conditions.

Pure phosphine is about 17 percent heavier than air. However, since it is given off slowly, it does not tend to stratify. Fans are not needed to ensure even distribution except when treating bulk commodities. Because of its low sorption and good penetration capacity, phosphine tends to leak from bins that are not gastight. Phosphine will go where the airflow goes.

## Precautions

Phosphine does not accumulate within body tissues as do other fumigants. Any phosphine gas entering the body will be eliminated within 48 hours. Even so, phosphine is very toxic to humans. The TWA is only 0.3 ppm. This means the gas is about 60 times as toxic as methyl bromide. However, because of the way phosphine is liberated and because of its distinct odor, it is far safer to handle than most other fumigants.

Always wear approved respiratory protection if the concentration of phosphine in the work area is likely to exceed an 8-hour TWA of 0.3 ppm. A gas mask/canister combination may be used at concentrations up to 15 ppm. Above this level, or when the concentration is unknown, you must wear an SCBA.

After the application, you must wear a respirator whenever the concentration of phosphine is unknown or exceeds 0.3 ppm. The TWA applies only during application. “Application” is the period covering the opening of the first container, applying the appropriate dosage of the fumigant and closing the site to be fumigated. At all other times, anyone exposed to fumigant concentrations exceeding 0.3 ppm must wear respiratory protection.

Always wear gloves when handling aluminum phosphide pellets, tablets, and the residue that remains after fumigation. Air out used gloves and other contaminated clothing in a well-ventilated area before washing them.



Wash your hands thoroughly after handling phosphide materials.

Phosphine is extremely flammable. Never open metal phosphide containers near an open flame or in a flammable atmosphere. Fire or an explosion can occur if the phosphine concentration is too high. It is better to open containers outdoors or near a fan. Phosphine may also ignite spontaneously at concentrations above 18,000 ppm. If you conduct the fumigation properly, however, concentrations will not approach this level. Phosphine is also explosive under vacuum conditions. Never use it for vacuum fumigation. Finally, do not stack or pile phosphine pellets or tablets. This can create a fire hazard.

To reduce the risk of fire, some phosphine products contain ammonium carbamate in their formulation. This helps to produce a gaseous mixture that will not burn or explode at normal application rates.

Both aluminum phosphide and magnesium phosphide can react violently if they contact water.

Never allow aluminum or magnesium phosphide or their residues to directly contact any processed food. To prevent this, place phosphide pellets or tablets on a tray or use packaged phosphine such as Prepacs, bags or plates. Do not add metal phosphide directly to any processed food. Aerate foods and feeds that have been treated with phosphine for 48 hours before giving them to the consumer.

Phosphine gas, especially at high temperatures and humidities, will corrode silver, copper and copper alloys. Copper-containing equipment, such as computers, telephones and other electrical devices, may be severely damaged. Protect or remove items that contain these metals during treatment.

## Aeration

Areas treated with phosphine aerate quickly. To be safe, open all doors and windows first to assure good ventilation. Then, while wearing respiratory protection, open the fumigated space or remove seals from the edges of a tarp. Some aerations will be complete in one to two hours. Others will require much longer aeration periods. Take gas readings to be sure concentrations are below 0.3 ppm.

## Detection

Several reliable gas detectors are available to measure phosphine gas. Glass detector tubes are the most common. Two types of glass tubes are available. The first measures low levels of gas (~0.1 to 40 ppm). Use this type of detector to determine worker exposure levels and to locate leaks. The second type of detector measures high levels of gas (~50 to 2,000 ppm). Use it to determine if phosphine levels during treatment are high enough to kill the target pest.

## Disposal

Metal phosphide fumigants leave a white powdery residue. This residue contains a small amount of unreacted phosphide that may or may not need to be deactivated. The deactivation process differs somewhat for aluminum phosphide and magnesium phosphide.

*NOTE: If the fumigant residue is grayish green, the metal phosphide is only partially spent. Extend the fumigation period until the residue turns white, or use extreme care during the deactivation process.*

To deactivate unreacted and partially reacted aluminum phosphide, prepare a deactivating solution. Fill a small to large container with water. Fifty-five-gallon drums work well for large amounts of aluminum phosphide. Add enough nonsudsing detergent to create a 2% solution. Fill the container to within a few inches of the top with the deactivating solution. Then, stir in the phosphide residue. Do not add more than about 45 to 50 pounds of phosphide to 15 gallons of water-detergent mixture.

To deactivate unreacted and partially reacted magnesium phosphide, no detergent is needed. Instead, fill a container to within a few inches of the top with water **ONLY**. Add the phosphide residue until it sinks to the bottom. Because unreacted or partially reacted magnesium phosphide reacts vigorously with water, be sure to add the residue slowly.

Always deactivate metal phosphide fumigants outdoors. Wear the appropriate respiratory equipment. Never place residue in enclosed containers. It could cause a fire hazard. After deactivating phosphide residues, dispose of the rinsate in a storm sewer, landfill or by other approved methods. Always check with local authorities for disposal regulations. Where permissible, bury the solid or spread it out on the ground.

## Test Your Knowledge

**Q. Name a fumigant that should not be used to treat food products.**

A. Chloropicrin.

**Q. Which fumigants do not have an odor at normal treatment concentrations?**

A. Methyl bromide and sulfuryl fluoride.

**Q. Which of the fumigants described in this unit are used for soil fumigation?**

A. 1,3-D, chloropicrin, dazomet, metam sodium and methyl bromide.

**Q. Which of the fumigants described in this unit are used to treat raw agricultural products?**

A. CO<sub>2</sub>, methyl bromide, sulfuryl fluoride and phosphine.

**Q. Which of the fumigants described in this unit can you apply via chemigation?**

A. 1,3-D and metam sodium.

**Q. What type of equipment should you use to apply non-EC formulations of 1,3-D?**

A. “Ripper-bedders” are recommended for row application of non-EC formulations of 1,3-D. A ripper-bedder is a subsoil shank followed by two bedder disks. Together, these are attached to a toolbar and perform a single operation. The shank fractures the hardpan in the soil, while the disks throw a mound of soil over the slit left by the shank. For broadcast fumigation, use chisel or bottom plows. Apply non-ECs through equipment that moves the product from a tank into the soil via pressure from a cylinder of nitrogen gas or from a pump – power take-off (PTO), electrical (explosion-proof) or ground-driven.

**Q. Which of the fumigants described in this unit are flammable?**

A. 1,3-D, and phosphine.

**Q. What fumigant is commonly added to methyl bromide and sulfuryl fluoride (sulfuryl fluoride or Vikane used in structures) to warn workers of its presence?**

A. Chloropicrin.

**Q. Describe how you would treat a small area or volume of soil with chloropicrin.**

A. Use a probe-type injection device to release the product 6 to 8 inches below the soil surface in a grid pattern. Space your injection points 12 inches apart. Tarp the treated soil to prevent premature loss of the fumigant from the soil.

**Q. Name three advantages of CO<sub>2</sub> fumigation.**

- A. 1. CO<sub>2</sub> does not leave harmful residues on treated commodities.  
2. If CO<sub>2</sub> leaks from a treatment area, it will be diluted by normal air and reach nontoxic levels quickly.  
3. CO<sub>2</sub> does not change the processing or biochemical properties of commodities.

**Q. How is CO<sub>2</sub> commonly stored and transported?**

A. As a liquid at 0°F and under a pressure of 300 psi.

**Q. What is the most effective concentration of CO<sub>2</sub>?**

A. 60 percent.

**Q. Describe the two methods available for treating stored products with CO<sub>2</sub>. When should you use each method?**

- A. 1. The top-down purge method adds CO<sub>2</sub> at the top of a structure. The CO<sub>2</sub> displaces the air in the structure as it settles downward. Use this method in concrete grain elevators where you can place the injection hose in the top of a well-sealed tank.

2. The lift method adds CO<sub>2</sub> at the bottom of the structure. In this case, the CO<sub>2</sub> displaces the air in the structure as it moves upward. Bottom injection (the lift method) works best in stand-alone steel bins where major leaks occur at the top around eaves and hatches.

**Q. Which two fumigants described in this unit decompose into the active ingredient methyl isothiocyanate (MITC)? How are each of these fumigants formulated?**

- A. Dazomet and metam sodium. Dazomet is formulated as a solid. Metam sodium is formulated as a liquid.

**Q. Describe three ways to apply dazomet to soil.**

- A. 1. Incorporation With Tarping: This method incorporates dazomet into the soil and then tarps the soil to seal in the fumigant.
2. Incorporation Without Tarping: This method incorporates dazomet into the soil and then rolls and irrigates the soil to seal in the fumigant.
3. Topical Application With Irrigation: This method applies dazomet to the top of the soil and then uses irrigation to seal in the fumigant.

**Q. Which application method would you select to treat a golf green with dazomet? Why?**

- A. Topical application with irrigation. This method uses water instead of tillage to draw dazomet into the soil.

**Q. If you have to fumigate a field with dazomet shortly before planting, how might dazomet affect the fertilization of the crop? How can you prevent this from being a problem?**

- A. Fumigation with dazomet can reduce the nitrification of fertilizers. You can decrease this risk by using fertilizers that contain a high percentage of nitrate nitrogen.

**Q. When applying metam sodium, at what percent of field capacity should the soil moisture be?**

- A. 50 to 80 percent.

**Q. What is the waiting period between fumigation and planting for metam sodium?**

- A. At least 21 days.

**Q. Which of the fumigants discussed in this unit is being phased out? Why? When might this occur?**

- A. At the time of this printing, methyl bromide is believed to contribute to the depletion of the earth's ozone layer. For this reason, the EPA has initiated action under the Clean Air Act to phase out the production and use of this fumigant. A 70 percent reduction in production was mandated by January 1, 2003. The complete phaseout of production was scheduled for January 1, 2005. The Environmental Protection Agency (EPA) is amending the regulations governing the phaseout of methyl bromide (MeBr) to allow for exempted production and import beyond the phaseout date of January 1, 2005, for critical uses and to address sales of pre-January 1, 2005 stocks of methyl bromide for critical uses. This rule makes approximately 8,942 metric tons of methyl bromide available for critical uses in 2005, which is 35 percent of the U.S. methyl bromide 1991 consumption baseline. The 1991 consumption baseline was established in the 1993 rulemaking, to cap and phase out methyl bromide production and import. An additional 2.5 percent of baseline was recently authorized for 2005 critical uses by the Parties to the Montreal Protocol at their meeting on November 26, 2004. EPA is beginning the notice-and-comment rule-making process on the supplemental amounts to make them available for critical uses as quickly as possible. It is your responsibility to keep up-to-date on any changes that affect the legal use of products you intend to use.

**Q. List several things you should NOT wear when working with sulfuryl fluoride, methyl bromide or chloropicrin.**

A. Goggles, jewelry, gloves, contact lenses or rubber boots.

**Q. What detection device is sensitive enough to check levels of methyl bromide before reentry into the treatment area?**

A. Glass detector tubes.

**Q. Which of the fumigants described in this unit are odorless at normal treatment concentrations?**

A. CO<sub>2</sub>, sulfuryl fluoride and methyl bromide.

**Q. Describe the difference between aluminum phosphide and magnesium phosphide.**

A. Aluminum phosphide is the main form of metal phosphide used to treat raw commodities. Magnesium phosphide is more reactive than aluminum phosphide. Magnesium phosphide is preferred when rapid release is

desired and when treatment is performed at lower temperatures and humidities. In addition, when deactivating phosphide residues, nonsudsing detergent is required for aluminum phosphide, whereas you only need to use plain water to deactivate magnesium phosphide.

**Q. What is responsible for liberating phosphine gas from its solid form?**

A. Moisture in the air (humidity).

**Q. What detection device is sensitive enough to check levels of sulfuryl fluoride before reentry into the treatment area?**

A. Only approved detection devices of sufficient sensitivity, such as specific types of gas analyzers or infrared detection systems (ambient air analyzers), can be used to confirm a concentration of sulfuryl fluoride of 1 ppm or less for Profume or 5 ppm for Vikane. At the time of this writing, the sulfuryl fluoride product label requires the use of an INTERSCAN or MIRAN analyzer, or similar approved device to measure gas concentrations for reentry.

# Appendix A. Sample Safety Checklists

## Safety Checklist

The following safety checklists will help you organize the many aspects of fumigation. They are organized so that you can photocopy them directly from this manual. This information is general. It does not apply to all fumigants in all situations. You can modify these checklists to meet your specific needs. Some manufacturers provide checklists specific to their products. Use these as well.

### Preliminary Planning A Safety Checklist for Fumigators

- ✓ Draw or locate a sketch of the structure you plan to fumigate. Indicate the layout of the structure, connecting structures and escape routes above and below ground.
- ✓ If you are in an industrial setting, inspect the equipment. It should be as tight as possible to prevent drafts or leaks. Be sure that production has stopped.
- ✓ Check all spouts, conveyors, conduits, heating ducts, or other possible openings leading from the areas that you plan to fumigate.
- ✓ Record the number and names of everyone who routinely enters the area. Also, note the proximity of other nearby people and animals. Keep children, unauthorized persons and pets away from the application site.
- ✓ If you plan to treat a commodity, learn about it. Find out its mode of storage and its condition. If possible, obtain a previous treatment history.
- ✓ If you plan to treat a structure, learn about it. What does it consist of: wood, brick, concrete? Note the locations of doors, windows and dividing walls. Predict airflow patterns.
- ✓ Locate connections and shut-offs for electricity, water and gas. Find the nearest telephone or communication device.
- ✓ Obtain and have handy telephone numbers for local health, fire, police and medical emergency services. Know how to contact the parties responsible for the structure and/or commodity you plan to fumigate.
- ✓ ONLY select a fumigant registered by the EPA and ASPB.
- ✓ Read and reread the label. Study the directions and precautions. Review the manufacturer's instruction manual. Make sure the fumigant is approved for the required work (site, commodity, etc.).
- ✓ Check, mark and prepare (tarp, seal, etc.) the points of application if the job involves spot fumigation.

- ✓ Notify the local health and fire departments, police and security personnel and the poison control center. Give them the following information: the location, the chemical name(s), the date and time of application, the type of gas mask and other safety equipment required, the fire hazard rating and literature about the safety measures you plan to use.
- ✓ Inform the occupants of the structure where treatment will occur. Also, notify the occupants of neighboring structures.
- ✓ Arrange for standby equipment and replacement parts. Outline an alternate plan of action.
- ✓ Review the fumigation plan with all workers. Explain the potential hazards to life and property, required safety measures and emergency procedures.
- ✓ Prepare warning signs to post near treated areas. Arrange for someone to monitor all entrances and exits during treatment.
- ✓ Have first aid equipment (including antidotes and plenty of fresh water) handy.
- ✓ If possible, plan for application from outside the structure.
- ✓ Seal all cracks, crevices, open fireplaces, broken windows, holes, pipes, chutes and conveyors.
- ✓ When necessary, obtain fans to evenly distribute the fumigant.
- ✓ Preplan how you will ventilate the area after treatment.
- ✓ Identify areas where you can store any excess fumigant(s). Be sure conditions in the storage area match those required by the label.
- ✓ Make sure no open fires, motors, or hot surfaces (heat pipes or electric fixtures) are within the space that you plan to treat.
- ✓ Know how to operate the gas detection devices.

## **Pre-Application Safety A Checklist for Fumigators**

- ✓ Open all doors and drawers inside the area you plan to treat.
- ✓ Shut off pilot lights and gas lights. Disconnect electrical equipment.
- ✓ Remove plastic covers from mattresses.
- ✓ Remove food, feed, drugs and medicines or place them in airtight containers. Sealing freezers and refrigerators will NOT prevent fumigant gas from getting inside.
- ✓ Make a final check. Be sure all occupants, pets, fish and plants have been removed from the structure.
- ✓ Place warning signs at all entrances and exits.
- ✓ Assign someone to observe all entrances and exits.

## **During-Application Safety A Checklist for Fumigators**

- ✓ Apply all fumigants according to label directions.
- ✓ Apply the fumigant from outside where appropriate.
- ✓ Consider the weather. Delay or cancel outdoor treatments on windy or stormy days.
- ✓ Do not enter the area where fumigant gas is being discharged, except in extreme emergencies.

## **Post-Application Safety A Checklist for Fumigators**

- ✓ Aerate according to structural limitations.
- ✓ Turn on ventilation fans where appropriate.
- ✓ Before reentering a treated area, use a suitable gas detector to determine the fumigant concentration. Some fumigants do not provide an adequate odor warning. Others aerate slowly.
- ✓ Remove warning signs only when aeration is complete.
- ✓ Dispose of or return empty containers per the manufacturer's instructions.
- ✓ When using metal phosphide fumigants, return any unused solid chemicals to clearly labeled containers. Store them properly.

# Personnel Safety

## A Checklist for Fumigators

**To protect yourself and others, be sure you and your supervisor(s) always:**

- ✓ Know the location of all entrances and exits.
- ✓ Know the location of all fumigant containers and aerating fans.
- ✓ Rehearse the fumigation plan so that each worker knows what to do.
- ✓ Remove all rings, jewelry and watches as required by the label.
- ✓ Have current health records for all employees. All workers that take part in fumigations must have a physical exam at least once a year. During fumigation, no worker should have a cold or other condition that may impair breathing, nor should any worker be undergoing medical or dental treatment, unless a physician certifies that they may work with fumigants.
- ✓ Survey workers to make sure they have abstained from alcoholic beverages 24 hours before and will abstain 24 hours after a fumigation job.
- ✓ Instruct all workers about first aid, emergency procedures, antidotes and decontamination.
- ✓ Work in pairs, especially when entry into a fumigated area is necessary. Stay in sight of one another while inside a treatment area.
- ✓ Report any accidents to your employer or supervisor.
- ✓ Report any signs of illness or discomfort, regardless of how minor they may seem. This includes dizziness, diarrhea, nausea, headaches and lack of coordination.
- ✓ Teach all workers how to select, operate and maintain protection devices. Warn them about the hazards that they may encounter if the chemicals are misused.
- ✓ Have and use the necessary personal protective equipment (PPE). Know where emergency equipment is located.
- ✓ Make sure there is enough water on site to wash or flush skin and eyes if an accident should occur.



# Preliminary Planning

## A Safety Checklist for Raw Commodity Fumigators

- ✓ Draw or locate a sketch of the structure you plan to fumigate. Indicate the layout of the structure, connecting structures and escape routes above and below ground.
- ✓ Seal all spouts, conveyors, conduits, heating ducts, pipes, cracks, crevices, broken windows and other possible openings leading from the areas that you plan to treat.
- ✓ Record the number and names of everyone who routinely enters the area. Note the proximity of other nearby people and animals. Keep children, unauthorized persons and pets away from the application site.
- ✓ If you plan to treat a commodity, learn about it. Find out its mode of storage and its condition. If possible, get a previous treatment history.
- ✓ If you plan to treat a commodity within a structure, learn about the structure. What does it consist of: wood, brick, concrete? Note the locations of doors, windows and dividing walls. Check airflow patterns.
- ✓ Study the pest(s) you plan to control. When is it most vulnerable to fumigants? Where are its numbers the highest?
- ✓ Check and adjust all safety and application equipment. Be sure the components can withstand the corrosiveness of the fumigant(s). When applying compressed gas, use pressure-approved components. Seal them tightly.
- ✓ Locate connections and shut-offs for electricity, water and gas. Test these shut-offs to be sure they are working. Find the nearest telephone or communication device.
- ✓ Obtain and have handy telephone numbers for local health, fire, police and medical emergency services. Know how to contact the parties responsible for the structure and/or commodity you plan to fumigate.
- ✓ ONLY select a fumigant registered by the EPA and ASPB.
- ✓ Read and reread the label information. Study the directions and precautions. Make sure the fumigant is labeled for the required work (site, commodity, etc.).
- ✓ Notify the local health and fire departments, police and security personnel and hospital. Give them the following information: the location, the chemical name(s), the date and time of application, the type of gas mask and other safety equipment required, the fire hazard rating and literature about the safety measures you plan to use.
- ✓ Inform the occupants of the structure where treatment will occur. Also, notify the occupants of neighboring structures.
- ✓ Arrange for standby equipment and replacement parts for application equipment and PPE. Outline an alternate plan of action.
- ✓ Review your treatment plan with all workers. Explain the potential hazards to life and property. Identify the safety measures and emergency procedures that are required by the label.

- ✓ Prepare warning signs to post near treated areas. Arrange for someone to monitor all entrances and exits during treatment.
- ✓ Have first aid equipment (including antidotes and plenty of fresh water) handy.
- ✓ If possible, plan for application from outside the structure.
- ✓ When necessary, obtain fans to evenly distribute the fumigant
- ✓ Preplan how you will aerate the area after treatment.
- ✓ Identify areas where you can store any excess fumigant(s). Be sure conditions in the storage area match those required by the label information.
- ✓ Make sure no open fires, motors, or hot surfaces (heat pipes or electric fixtures) are within the space that you plan to treat.
- ✓ Know how to operate the gas detection devices.
- ✓ Have on hand all the PPE you would need to enter a treated area in an emergency. Check to be sure that this equipment is working properly.

# Application Safety

## A Checklist for Raw Commodity Fumigators

### Pre-Application

- ✓ Open all doors and drawers inside the area you plan to treat.
- ✓ Turn off pilot lights and gas lights. Disconnect electrical equipment.
- ✓ Make a final check. Be sure all occupants, pets and livestock have been removed from the structure.
- ✓ Place warning signs at all entrances and exits.
- ✓ Assign someone to observe all entrances and exits.

### During Application

- ✓ Apply all fumigants according to the directions in the label information.
- ✓ Apply the fumigant from outside where appropriate.
- ✓ Consider the weather. You may need to delay or cancel outdoor treatments on windy or stormy days.
- ✓ Do not enter the area where fumigant gas is being discharged, except in extreme emergencies.

### Post Application

- ✓ Aerate according to structural limitations.
- ✓ Turn on ventilation fans where appropriate.
- ✓ Before reentering a treated area, use a suitable gas detector to determine the fumigant concentration. Some fumigants do not provide an adequate odor warning. Others aerate slowly.
- ✓ Remove warning signs only when aeration is complete.
- ✓ Dispose of or return empty containers per the manufacturer's instructions.
- ✓ When using metal phosphide fumigants, return any unused, solid chemicals to clearly labeled containers. Store them properly.

# Personnel Safety

## A Checklist for Commodity Fumigators

**To protect yourself and others, be sure you and your supervisor(s) always:**

- ✓ Know the location of all entrances and exits.
- ✓ Know the location of all fumigant containers and aerating fans.
- ✓ Rehearse the fumigation plan so that each worker knows what to do.
- ✓ Remove all rings, jewelry and watches as required by the label.
- ✓ Have current health records for all employees. All workers that take part in fumigations must have a physical exam at least once a year. During fumigation, no worker should have a cold or other condition that may impair breathing. Nor should any worker be undergoing medical or dental treatment, unless a physician certifies that they may work with fumigants.
- ✓ Survey workers to make sure they have abstained from alcoholic beverages 24 hours before and will abstain 24 hours after a fumigation job.
- ✓ Instruct all workers about first aid, emergency procedures, antidotes and decontamination.
- ✓ Work in pairs, especially when entry into a fumigated area is necessary. Stay in sight of one another while inside a treatment area.
- ✓ Report any accidents to your employer or supervisor.
- ✓ Report any signs of illness or discomfort, regardless of how minor they may seem. This includes dizziness, diarrhea, nausea, headaches and lack of coordination.
- ✓ Teach all workers how to select, operate and maintain protection devices. Warn them about the hazards that they may encounter if the chemicals are misused.
- ✓ Have and use the necessary PPE. Inspect all PPE for defects. Know where emergency equipment is located.
- ✓ Make sure there is enough water on site to wash or flush skin and eyes if an accident should occur.

# Preliminary Planning

## A Safety Checklist for Soil Fumigators

- ✓ Note the proximity of nearby people and animals. Keep children, unauthorized persons and pets away from the application site.
- ✓ Know the soil you plan to treat. What is its temperature, moisture level and texture? How much organic matter does it contain? Is it well aerated or compacted?
- ✓ Know the pest(s) you plan to control. When is it most vulnerable to fumigants? Which application methods are most effective and efficient?
- ✓ Check and adjust all safety and application equipment. Be sure the components can withstand the corrosiveness of the fumigant(s). When applying compressed gas, use pressure-approved components. Seal them tightly.
- ✓ Be sure that there is a properly-functioning check valve in the line between the cylinder of propellant and the fumigant cylinder.
- ✓ Find the nearest telephone or communication device.
- ✓ Obtain and have handy telephone numbers for local health, fire, police and medical emergency services.
- ✓ ONLY select a fumigant registered by the EPA and ASPB.
- ✓ Read and reread the label information. Study the directions and precautions. Make sure the fumigant is labeled for the desired use.
- ✓ Arrange for standby equipment and replacement parts. Outline an alternate plan of action.
- ✓ Review the fumigation plan with all workers. Explain the potential hazards to life and property, required safety measures and emergency procedures.
- ✓ Prepare warning signs to post near treated areas.
- ✓ Have first aid equipment (including antidotes and plenty of fresh water) handy.
- ✓ Identify areas where you can store any excess fumigant(s). Be sure conditions in the storage area match those required by the label information.
- ✓ Have on hand all the PPE you would need to enter a treated area in an emergency. Check to be sure that this equipment is working properly.

# Application Safety

## A Checklist for Soil Fumigators

### Pre-Application

- ✓ Place warning signs at all appropriate access points.

### During Application

- ✓ Apply all fumigants according to the directions in the label information.
- ✓ Consider the weather. You may need to delay or cancel treatments on windy or stormy days.
- ✓ Do not enter the area where fumigant gas is being discharged, except in extreme emergencies.

### Post Application

- ✓ Observe all reentry period, PPE and waiting period specifications on the label for the fumigant that you use.
- ✓ Avoid reentering treated areas when you can still detect the fumigant odor. Although gas detectors are rarely used with soil fumigation, they may be appropriate in some situations where fumigant concentrations may be high. You will need to use a gas detector when reentering an enclosed structure where soil or potting mixes have been fumigated. Remember that some fumigants do not provide an adequate odor warning. Others aerate slowly.
- ✓ Do not begin planting until after the “waiting period” is over. The waiting period is the number of days between when you apply a fumigant and when aeration is complete.
- ✓ Remove warning signs once the reentry interval has expired.
- ✓ Dispose of or return empty containers per the manufacturer’s instructions.

# Personnel Safety

## A Checklist for Soil Fumigators

**To protect yourself and others, always:**

- ✓ Rehearse the fumigation plan so that each worker knows what to do.
- ✓ Remove all rings, jewelry and watches as required by the label.
- ✓ Have current health records for all employees. During fumigation, no worker should have a cold or other condition that may impair breathing. Nor should any worker be undergoing medical or dental treatment, unless a physician certifies that they may work with fumigants.
- ✓ Survey workers to make sure they have abstained from alcoholic beverages 24 hours before and will abstain 24 hours after a fumigation job.
- ✓ Instruct all workers about first aid, emergency procedures, antidotes and decontamination.
- ✓ Work in pairs, especially when entry into a fumigated area is necessary. Stay in sight of one another while inside a treatment area.
- ✓ Report any accidents to your employer or supervisor.
- ✓ Report any signs of illness or physical discomfort, regardless of how minor they may seem. This includes dizziness, diarrhea, nausea, headaches and lack of coordination.
- ✓ Teach all workers how to select, operate and maintain protection devices. Warn them about the hazards that they may encounter if the chemicals are misused.
- ✓ Have and use the necessary PPE. Inspect all PPE for defects. Know where emergency equipment is located.
- ✓ Make sure there is enough water on site to wash or flush skin and eyes if an accident should occur.





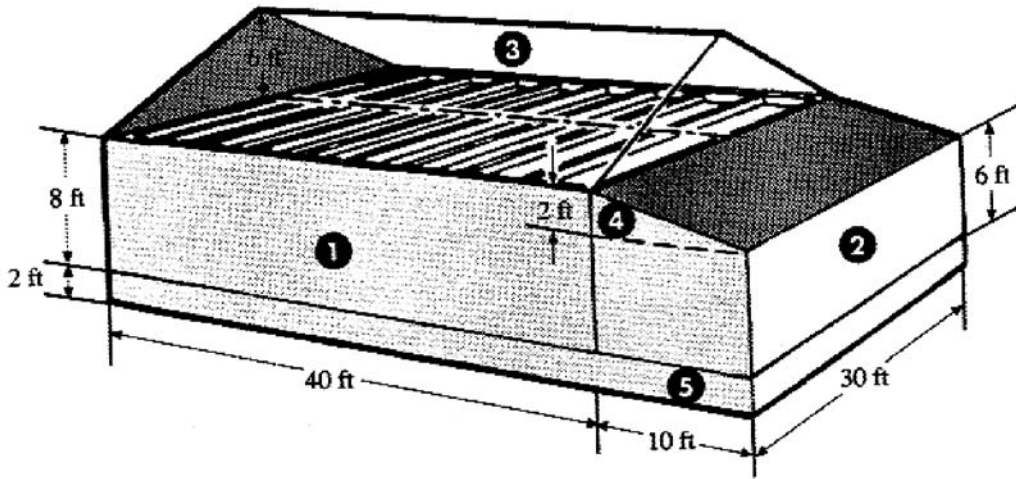

Figure 3

**Volume of Section 2:**

$$30 \text{ ft} \times 10 \text{ ft} = 300 \text{ sq ft}$$

$$300 \text{ sq ft} \times 6 \text{ ft} = 1,800 \text{ cu ft}$$

**Volume of Section 3:**

$$40 \text{ ft} \times 30 \text{ ft} = 1,200 \text{ sq ft}$$

$$1,200 \text{ sq ft} \times 3 \text{ ft (1/2 of loft height)} = 3,600 \text{ cu ft}$$

**Volume of Section 4:**

$$30 \text{ ft} \times 10 \text{ ft} = 300 \text{ sq ft}$$

$$300 \text{ sq ft} \times 1 \text{ ft (1/2 of loft height)} = 300 \text{ cu ft}$$

**Volume of Section 5:**

$$40 \text{ ft} \times 30 \text{ ft} = 1,200 \text{ sq ft}$$

$$30 \text{ ft} \times 10 \text{ ft} = 300 \text{ sq ft}$$

$$1,200 \text{ sq ft} + 300 \text{ sq ft} = 1,500 \text{ sq ft}$$

$$1,500 \text{ sq ft} \times 2 \text{ ft (height of subarea)} = 3,000 \text{ cu ft}$$

Total volume would be the sum of all area volumes:

$$\begin{array}{r}
 9,600 \\
 1,800 \\
 3,600 \\
 300 \\
 \underline{3,000} \\
 \text{Total square feet} = 18,300
 \end{array}$$

## Calculating Average Height

Calculating the average height of a building is a critical step in figuring volume. Several methods are available. To figure the average height of a building with a gable roof, multiply one-half the distance from the ground-floor ceiling to the peak of the roof by the number of square feet in the loft. Another method is to multiply the maximum height at the peak by the number of square feet and divide the result by two.

If the building has a simple roof, without dormer or extra gables, as in Figure 4, you can calculate the average height of the total building by adding the wall height and one-half of the loft height.

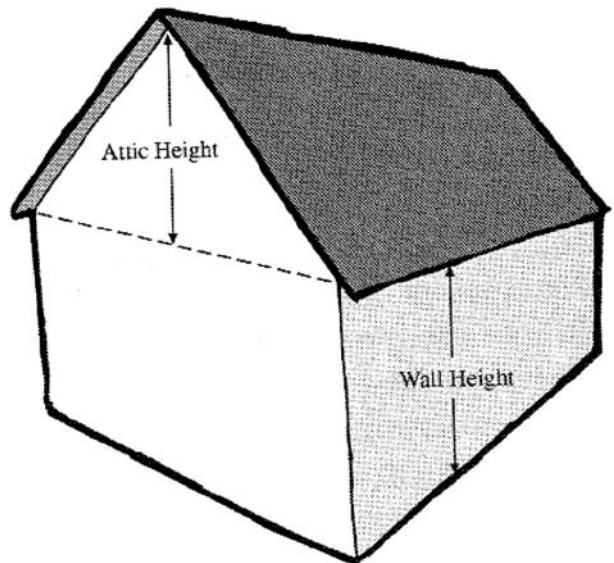

Figure 4

To measure the average height of the building in Figure 5, find the midway point between roof peak and eave. From there, measure to the ground. If the terrain is sloping or access to the outside is difficult, it is useful to measure the roof from inside while making the inspection.

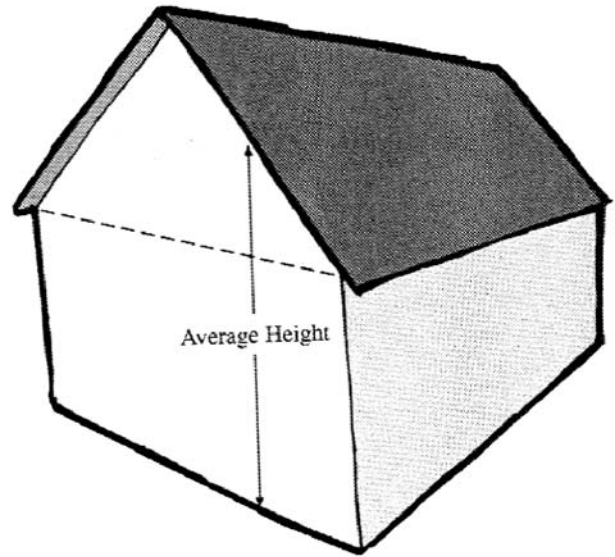

Figure 5

## Calculating the Volume of Grain Bins

Grain bins are usually cylindrical, with cone-shaped caps. To calculate the volume (cubic content) of a grain bin, you must know how to figure the volume of a cylinder and a cone:

$$\text{Volume of a cylinder} = 3.14 \times r^2 \times h$$

$$\text{Volume of a cone} = \frac{3.14 \times r^2 \times h}{3}$$

r = radius (1/2 of the diameter of the circular base of the bin)

h = height of the cylindrical part of the bin

3.14 is a constant often called "pi" and represented as  $\pi$

**Example 1:** Figure 6 shows a basic grain bin. The height of the cylindrical part of the bin is 25 feet. The diameter of the circular base of the bin is 20 feet. The height of the cone-shaped cap is 5 feet. With these dimensions, calculate the total volume (cubic content) inside the bin.

$$\begin{aligned} \text{Volume of the cylindrical portion} \\ \text{of the bin} &= 3.14 \times (10 \text{ feet})^2 \times 25 \text{ feet} \\ &= 7,850 \text{ cubic feet} \end{aligned}$$

$$\begin{aligned} \text{Volume of the cone-shaped cap} &= 3.14 \times (10 \text{ ft})^2 \times 5 \text{ feet} \\ &= \frac{1,570 \text{ cubic feet}}{3} \end{aligned}$$

Total volume

$$\begin{array}{r} 523.3 \text{ cubic feet} \\ 7,850.0 \text{ cubic feet} \\ + \underline{523.3 \text{ cubic feet}} \\ 8,373.3 \text{ cubic feet} \end{array}$$

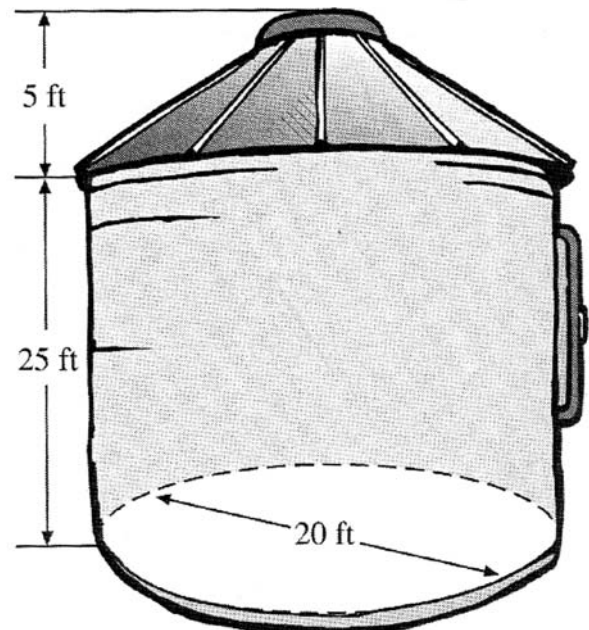

Figure 6

Issued in furtherance of Cooperative Extension work, Acts of May 8 and June 30, 1914, in cooperation with the U.S. Department of Agriculture, Director, Cooperative Extension Service, University of Arkansas. The Arkansas Cooperative Extension Service offers its programs to all eligible persons regardless of race, color, national origin, religion, gender, age, disability, marital or veteran status, or any other legally protected status, and is an Affirmative Action/Equal Opportunity Employer.

**AG1161-5-19RV**