

# Golf Course Pest Control

Commercial Applicator – Classification 6  
Noncommercial Applicator – Classification 10

## Training Manual



# Golf Course Pest Control

## Edited by

**Dr. John D. Hopkins**, Professor and Extension Urban Entomologist, University of Arkansas Cooperative Extension Service.

## Contributors

**Dr. John Boyd**, Professor and Extension Weed Scientist, University of Arkansas Cooperative Extension Service.

**Dr. John D. Hopkins**, Professor and Extension Urban Entomologist, University of Arkansas Cooperative Extension Service.

**Dr. Rebecca McPeake**, Professor and Extension Specialist-Wildlife, University of Arkansas Cooperative Extension Service.

**Dr. Stephen Vann**, Assistant Professor and Extension Plant Pathologist, University of Arkansas Cooperative Extension Service (retired).

# Preface

This manual provides information for the Arkansas commercial pesticide applicator wishing to become certified in Classification 6 – Golf Course Pest Control and the noncommercial pesticide applicator wishing to become certified in Classification 10 – Golf Course Pest Control. To become a certified applicator in the desired category, a candidate must pass both a general standards exam and pass an examination based primarily on the material presented in this manual and Circular 6, Arkansas Pest Control Law (Act 488 of 1975, as amended). Information covered in the general standards examination is contained in “A Guide for Private and Commercial Applicators: Applying Pesticides Correctly.” Refer to Circular 6, Arkansas Pest Control Law (Act 488 of 1975, as amended) for specific requirements for Classifications 6 and 10. The Arkansas State Plant Board administers the examinations. Up-to-date study materials can be obtained from the Arkansas State Plant Board, #1 Natural Resources Drive (P. O. Box 1069), Little Rock, AR 72203-1069, phone (501) 225-1598. Additional study information may be obtained from the University of Arkansas Cooperative Extension Service, the pesticide label, current publications on the subject, pesticide distributors and manufacturers.

## Acknowledgments

Information accumulates from direct observations, scientific literature and anecdotes from others. Information from these sources blurs together quickly, and consequently, unique ideas are rare in society. Credit for sources of information on golf course pest control and management must go to land grant university extension and research workers in the areas of entomology, horticulture, plant pathology and weed science who continually work to maintain and update golf course pest management information. In addition, thanks go to pest control industry workers who hold training sessions nationally, regionally and locally where information is disseminated among the experienced and provided to the inexperienced, the Environmental Protection Agency whose personnel molded modern training and influenced the need for national uniformity in training requirements, and state regulatory personnel who cooperate with university and industry personnel and who strongly emphasized the importance of training.

This training material has been adapted from commercial applicator certification training manuals for turf pests developed by the Oklahoma Cooperative Extension Service, Division of Agricultural Sciences and Natural Resources, Oklahoma State University; Texas Agricultural Extension Service, the Texas A&M University System; and University of Nebraska Cooperative Extension, University of Nebraska-Lincoln.

Special thanks go to Jim Criswell, Extension Pesticide Coordinator; Gerrit Cuperus, Extension IPM Coordinator; Ken Pinkston, Extension Entomologist, Richard Price, Professor, Entomology, Don Arnold, Survey Entomologist, Mark Andrews, County Extension Horticulture Agent, Mike Kenna, Extension Turfgrass Specialist, Joel Barber, Assistant Professor, Turfgrass, Douglas Montgomery, Extension Assistant, Turfgrass, Randy Taylor, Extension Assistant Agricultural Engineering, Willard Downs, Associate Professor Agricultural Engineering, all with Oklahoma State University; Mark A. Matocha, Extension Program Specialist and Don L. Renchie, Assistant Professor and Extension Specialist, Texas A&M University, Texas Cooperative Extension; Clyde L. Ogg, Extension Educator-Pesticide Education and Dean Herzfeld, Coordinator, Health, Environmental, and Pesticide Safety program, University of Nebraska Cooperative Extension; and George N. Agrios, Department of Plant Pathology, University of Florida for their kind permission to adapt their respective manuals.

Further acknowledgements go to Lisa M. Williams-Whitmer, Margaret C. Brittingham and Mary Jo Casalena, College of Agricultural Science, Pennsylvania State University Cooperative Extension, and the Arkansas Game and Fish Commission for their information and help in preparing the goose management sections.

# Table of Contents

	<b>Page</b>
Introduction to Golf Course Pest Management . . . . .	1
Turfgrass Management . . . . .	2
Golf Course Weed Management . . . . .	9
Turfgrass Disease Management . . . . .	26
Turfgrass Insect Pest Management . . . . .	33
Vertebrate Pest Management . . . . .	46
Pesticide Application . . . . .	52
Selected Turfgrass References and Study Material. . . . .	64
Turfgrass Glossary . . . . .	66

# Introduction to Golf Course Pest Management

A turfgrass pest is any organism causing deterioration in the aesthetic or functional value of turfgrass. Pests include weeds, insects and mites, nematodes, diseases and vertebrate mammals.

When pests are mentioned, pesticides are considered as important means for achieving control. Pesticides are valuable components of a turfgrass management program, but pest management includes more than selecting and applying the appropriate pesticide. The concept of integrated pest management (IPM) begins with selection of a well-adapted turfgrass, following proper establishment procedures and implementing cultural practices that favor healthy turfgrass growth. Therefore, IPM is the proper use of pesticides in conjunction with a sound cultural program that ensures high-quality turfgrass.

Weeds and diseases are often indicative of unfavorable growing conditions for specific turfgrasses. Their incidence can be prevented or, at least, substantially reduced where favorable

turfgrass growth conditions prevail. Damage from insects and mites, nematodes and other animals is often greater where the turfgrass is also subjected to other stresses. Many pests can be effectively controlled as long as vigorous turfgrass growth is favored. As often as not, pest activity is the result of underlying cultural problems rather than the problem pest itself.

Symptoms associated with various pests and cultural problems are often similar and easily confused. As a result, pests can inflict extensive damage before proper control measures can be started. Therefore, the first step toward the alleviation of any turfgrass pest problem must be proper identification.

The following chapters in this manual are designed to help turfgrass managers understand cultural practices that promote a healthy turf, properly identify pest problems, understand conditions that favor these pests and review the principles of safe and proper pesticide application.

# Turfgrass Management

## Introduction

Preventing pests from invading a turf area starts with maintaining a healthy, vigorously growing stand of turfgrass plants. Pests usually take advantage of a turfgrass exposed to long periods of environmental stress, improper cultural practices or selection of the wrong turfgrass for the area. Pesticides alone will not guarantee a successful pest management program.

Turfgrass maintenance requires timely implementation and use of cultural practices and pesticides. Simply stated, it is the “how to” and “when to” of maintaining turfgrasses. Turfgrass maintenance requires a year-round commitment of care from the turf manager and a monetary commitment to provide the necessary funds for equipment and supplies from club, community or school organizations.

## Turfgrass Selection

Turfgrass selection should be based on the environment, the intended use and expected management intensity. Check with a turfgrass specialist or Extension agent to find out which grasses perform best in a given area. Blends and mixtures should be used whenever possible to ensure good performance over a wide range of conditions. Cool-season grasses (bentgrass, bluegrass, ryegrass, fescue) are best established in the fall, whereas warm-season grasses (bermudagrass, zoysiagrass, centipedegrass, St. Augustinegrass) are best planted in late spring or early summer.

Use of improved, adapted, turf-type grasses, free of objectionable weed and crop content, is one of the best means of preventing pest activity. A number of cultivars have been released with improved tolerance to certain diseases, such as leaf spot, rust, dollar spot and others. Several cultivars are also being marketed which claim resistance to certain insects. Insist on certified seed or sod to ensure high genetic purity. Uncertified seed or sod frequently produces plants of low quality that are very difficult to manage.

## Cultural Practices

### Mowing

Mowing schedules should be based on the desired cutting height and amount of plant growth allowed between mowings. The growth rate will depend on the level of soil moisture, nutrients, temperature and sunlight. Since these factors fluctuate from week to week, it follows that plant growth also fluctuates. Therefore, the time to cut turfgrasses is at a point so no more than one-third of the leaf area is removed at any one mowing. To maintain a turf at 1 inch, it should be cut when it reaches 1 1/2 inches (**Table 2.1**). Scalping or removing too much of the leaf area in a single mowing can cause plant stress and reduces the aesthetic value of the area.

**TABLE 2.1. Cutting Height and Amount of Growth Allowed So No More Than 1/3 of the Leaf Area Is Removed**

Cutting Height	Growth Allowed	Maximum Height Allowed*
1/2	1/4	3/4
5/8	1/4	7/8
3/4	3/8	1 1/8
7/8	1/2	1 3/8
1	1/2	1 1/2
1 1/2	3/4	2 1/4
2	1	3
2 1/2	1 1/4	3 3/4
3	1 1/4	4 1/4

\*Please note that these values are to be used as guidelines and illustrate how the growth allowed is a direct function of the desired cutting height (i.e., maximum height allowed = 3/2 x desired cutting height).

Reel-type mowers provide the best mowing quality if properly maintained and operated. Rotary mowers are more versatile but may not cut as “clean” as a reel-type mower. Flail mowers are generally not used for fine turf because they are not designed to provide a quality cut at 1 inch or below. They are best suited for roadsides and utility turfgrass areas that are infrequently mowed at cutting heights of 2 to 3 inches or more. Regardless of the

type of mower used, it is essential that mowing equipment be kept sharp and in good operating condition. Dull, improperly adjusted equipment bruises leaf tips, induces plant stress and destroys the aesthetic value of the area.

## Irrigation

Irrigation is required to maintain soil moisture levels that support optimal turfgrass growth during periods of low or uneven rainfall. However, watering is one of the most often abused and misunderstood aspects of turfgrass culture. Frequent, shallow watering encourages shallow rooting, soil compaction, thatch accumulation, weed seed germination and disease development.

Irrigation frequency should be determined by the moisture needs of the turfgrass. It is difficult to schedule a definite irrigation frequency because of (1) dissimilar water-holding capacities of different soil types, (2) weekly fluctuations in temperature, humidity and wind and (3) the influence of management practices such as mowing and fertilization on turfgrass water consumption. Sandy coarse-textured soils absorb water faster but retain less water than fine-textured clay soils (**Figure 2.1**). Therefore, more frequent applications of less water are required for turfgrass areas constructed on a sandy soil than those on a clay soil. Close mowing and increased applications of fertilizer accelerate growth and increase the amount of water necessary for optimal turfgrass growth.

Turfgrasses should be irrigated when they show the first visual symptoms of wilt that is characterized by “foot printing” and a blue-gray appearance. Water constitutes approximately 80 percent of the fresh weight of turfgrasses. When turfgrasses experience moisture stress, their leaves begin to curl and wilt. Thus, the leaves are slower to bounce back when stepped on or driven over. Apply enough water to wet the soil to a 6-inch depth. This can be checked with a soil probe. If the turf area begins to puddle, stop irrigating and allow the water to soak into the soil. It may be necessary to repeat this cycle several times before irrigation to the proper depth is complete.

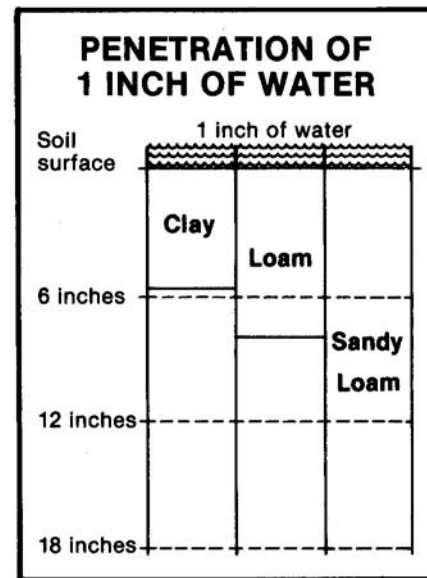

**FIGURE 2.1.** One inch of water will penetrate approximately 6 inches into clay soil and 18 inches into sandy loam soil.

## Fertilization

Turfgrass plants require nitrogen (N), phosphorus (P), potassium (K) and 10 other mineral elements in available forms within the soil root-zone. Nitrogen fertilizer is particularly important because it is the nutrient required in the greatest amount by turfgrass (a healthy turfgrass plant is approximately 4% N, 0.5% P and 2% K, by dry weight).

Nitrogen applications are necessary because available nitrogen is negligible in most topsoils of Arkansas. The level of nitrogen within a turfgrass plant is correlated with plant color and vigor. However, excessive levels of nitrogen can lead to poor rooting, higher disease incidence and reduced tolerance to environmental stress, so it is best to maintain turfgrasses “just on the lean side.” Phosphorus and potassium are also required in relatively large quantities for healthy plant growth. Applications of phosphorus and potassium are not needed as frequently as nitrogen because lower levels are required. It is common for these nutrients to be available at adequate levels within native topsoils of Oklahoma.

Sources of nitrogen that are quickly available – ammonium nitrate, ammonium sulfate or urea – are highly water soluble, cause a rapid but short-term

growth response, have a high burn potential and have a low cost per unit nitrogen. Sources of nitrogen that are slowly available – ureaformaldehyde (UF, Nitroform), isobutylidene diurea (IBDU), sulfur-coated urea (SCU) and activated sewage sludge (Milorganite) – generally produce a gradual long-term turfgrass response, have a low burn potential and have a moderate to high cost per unit nitrogen.

A complete fertilizer (one that contains nitrogen, phosphorus and potassium) may be necessary only once or twice a year, with the remaining applications consisting of a nitrogen-only source. Fertilizer formulations having a grade similar to 12-4-8 or 24-8-16 provide mineral elements closer to actual plant needs than fertilizer formulations such as 10-10-10 or 10-20-10. Apply no more than 1 to 1 1/2 pounds of quickly available nitrogen per 1,000 square feet in a single application. Higher

rates cause increased shoot growth without corresponding increases in turfgrass quality. Slowly available fertilizers have a longer residual response. Nutrients are released for a duration that is two to three times longer than quickly available fertilizers. Therefore, fewer applications at higher rates are needed for slowly available fertilizers.

The availability of plant nutrient elements in the soil is influenced by soil pH. These nutrient elements are available at specific pH levels (**Figure 2.2**). Between pH 6.5 and 7.0, all essential elements are adequately available for optimal turfgrass growth. To economically maintain optimum soil fertility, a soil test determining pH and levels of available phosphorus and potassium is beneficial. Lime (to increase pH) or sulfur (to reduce pH) **should only** be applied when recommended by a soil test.

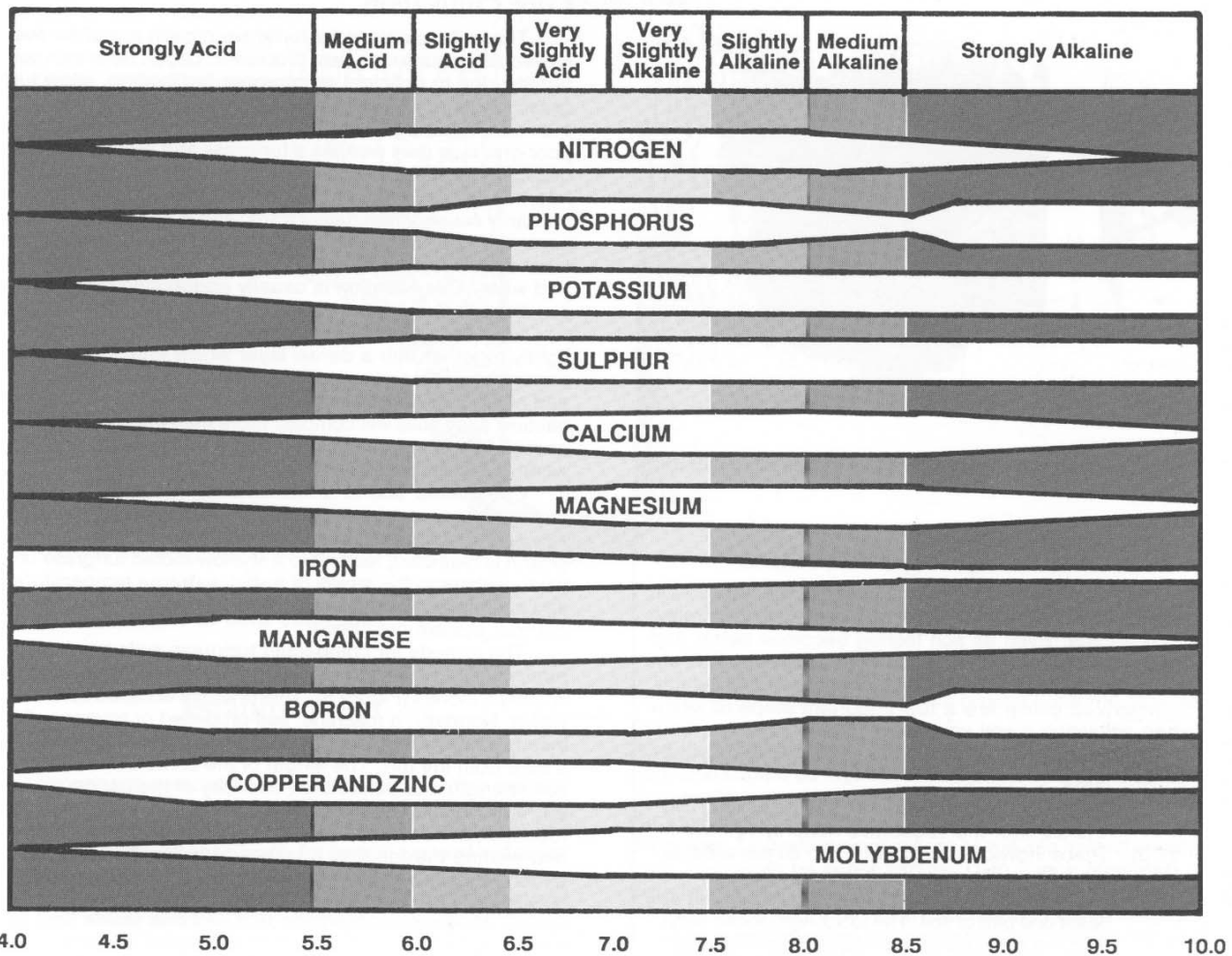

FIGURE 2.2. Nutrient availability as influenced by soil pH.



## Preventing Thatch

Thatch is a layer of undecayed grass found between the soil and green leaves of the turf plant. Thatch occurs as old turf plants age, die and decompose into fine-textured humus that becomes part of the soil surface. Some factors that favor thatch buildup are:

- Excessive growth from over fertilization,
- Overgrowth followed by severe cutting,
- Fungus disease, and
- Conditions unfavorable to microorganisms that decompose dead turf plants.

Rapid and excessive growth is the major cause of thatch because plant material is produced at a faster rate than decomposition can occur. Good cultural practices may not prevent thatch indefinitely but can retard its formation. Some of these practices include:

- Moderate and regular fertilization of the soil to maintain turf vigor without excessive growth.
- Regular mowing at the proper height to avoid plant stress.
- Deep, soaking irrigations during dry periods to encourage deep rooting.
- Vertical mowing annually before a new flush of growth.
- Aerification to improve water penetration and reduce compaction.

To determine if thatch is a problem, cut and lift several plugs 2 to 3 inches deep. Examine the profile of the plug. If thatch is present, it will appear as a distinct layer of felt-like material that is partially decomposed (**Figure 2.3**).

A thatch layer in excess of 1/3 inch should be removed by a verticutter, power rake or dethatching machine. Cool-season species should have thatch removed in the fall and spring months. Warm-season species can be lightly dethatched before greenup in late winter or early spring (before March 15) or heavily dethatched after the turf is completely green in late spring or early summer (May or June).

In severe situations, removal of thatch by mechanical means will also remove most of the green, living grass. Moderate treatments over two to three years are more desirable than complete removal in a single operation.

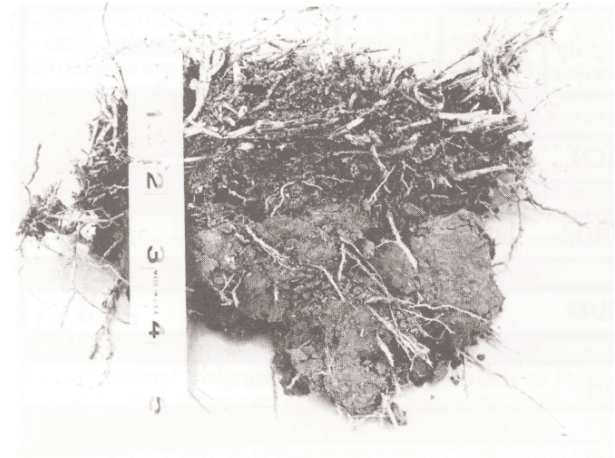

**FIGURE 2.3. A bermuda turf with heavy thatch accumulation.**

## Soil Sampling Procedure

The use of soil testing as a guide to the application of agricultural chemicals on turfgrass continues to increase in Arkansas. Even as soil testing becomes better and more widely used, getting a good soil sample stands out as a major factor affecting the usefulness of soil testing. Summarized below are a few important steps to follow when collecting a soil sample:

1. Follow a random pattern when sampling a turf area.
2. Individual sample depths should be at least two inches with the vegetative material removed.
3. Place individual samples (15 to 20 per area) in a clean container and mix thoroughly.
4. The test sample for the area should contain at least one pint of soil. Soil sample containers are provided free-of-charge through your county Extension office.

## Core Cultivation

The soil conditions for turfgrass growth are often overlooked as a cause for a pest problem. Soils with poor fertility, due to deficient or improper

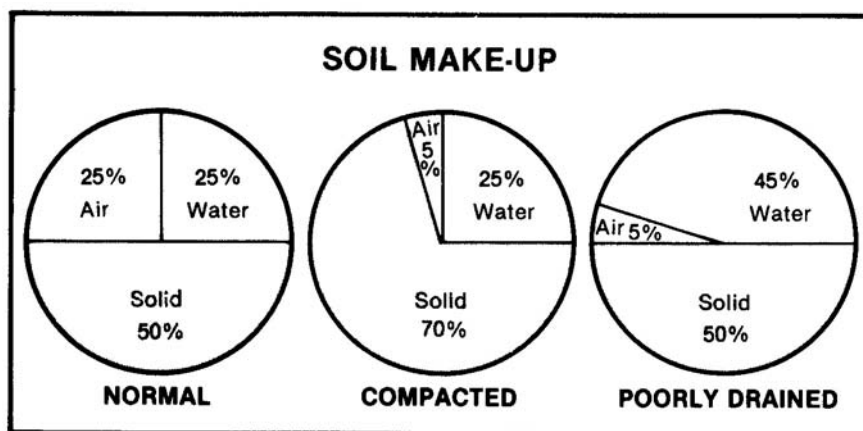

FIGURE 2.4. "Normal soil" contains 50 percent soil material, 25 percent air and 25 percent water. Compacted soil has too little air space, and poor drainage occurs when the soil holds too much water.

fertilization, allow turfgrass pests to invade an area. Even though the area is mowed, irrigated and fertilized properly, soil compaction or poor drainage may weaken a turfgrass and increase its susceptibility to turfgrass pests. Soil compaction causes poor internal soil aeration and water drainage (Figure 2.4). It is primarily caused by heavy traffic and is more likely in soils containing clay. The end result is a turf area characterized by shallow-rooted plants that cannot withstand heavy use and wear. This situation is usually aggravated by irrigation practices that are too frequent and too light.

Soil compaction occurs when soil particles are pressed tightly together into a dense layer that impairs soil aeration and water movement. The centers of most football fields and along sidewalks or cart paths are areas prone to compaction. Clay soils will compact more than sandy soils. Compaction can occur quickly any time a turfgrass area is used when it is wet, particularly those constructed of clay.

Compacted soil is detrimental to the growth of turfgrasses because it impedes the entry and movement of air, water and nutrients into and within the root-zone soil. Root growth is restricted, leading to a shallow-rooted turfgrass unable to withstand the stress of traffic, extreme temperatures and low moisture. In severe cases of compaction, death of the root system may occur.

The remedy for compacted turfgrass soils involves the removal of 1/4 to 3/4 inch diameter cores to a depth of approximately 3 inches (Figure 2.5). This practice is called core cultivation. Normally, a machine, self-propelled or tractor-pulled, inserts a hollow metal tine or spoon into the soil and extracts a core from the turf. The length of the cores will vary due to soil strength and penetration capacity of the coring device, but they should be at least 2 inches in length for effective reduction of soil compaction. Adding weight to the machine and wetting the top 4 to 6 inches of soil, one to two days prior to core cultivation, will aid in the penetration of metal tines or spoons.

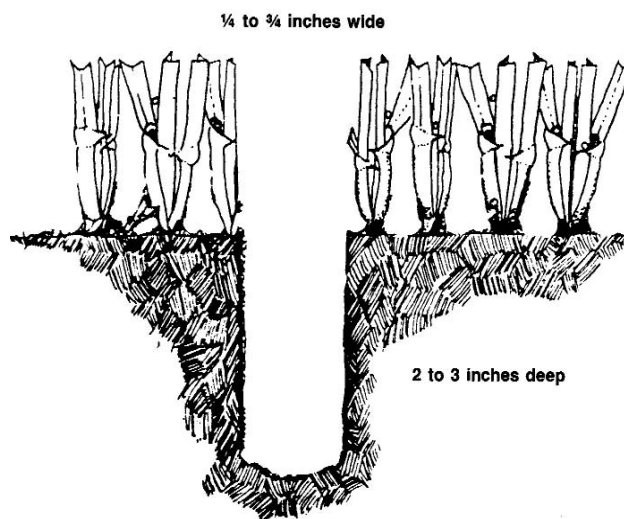

FIGURE 2.5. Example of core cultivation.

# Establishment

## Site Selection and Preparation

Proper site selection and preparation can help prevent the development of future problems. Good soil and surface drainage can help reduce disease and weed problems. Soil mixtures developed specifically for certain types of turf areas can aid soil drainage, prevent soil compaction and provide an environment favorable for good growth. Wise tree removal can limit shade and tree root competition as well as reduce environmental conditions favorable for pest development. Certain diseases such as pythium blight are more likely to occur where trees or dense undergrowth impedes air movement.

Soil amendments (sand, organic matter, etc.) to improve drainage, as well as fertilizer and lime, are best incorporated prior to seeding. The type and quantity of amendments should be determined from chemical and physical soil tests. Soil test results are only as good as the sample submitted; therefore, care should be taken to ensure that each sample is representative of each site. Amendments should be evenly spread and thoroughly incorporated to be most effective and to eliminate a future nonuniform appearance of the turf.

## Methods

Depending on the cultivar and species, turfgrasses can be seeded or vegetatively propagated by sodding, plugging, sprigging or stolonizing.

The methods of turfgrass establishment are briefly described below.

**Seeding:** Broadcasting clean, pest-free seed uniformly across an area is an important first step. The seed should be gently incorporated into the surface soil (1/8 to 1/4 inch) and rolled and pressed into the soil to establish good seed-soil contact. Keep area moist for at least the first 10 to 14 days by frequent, gentle, daily waterings. One week after the seedlings have emerged, start watering with greater amounts, less frequently.

**Sodding:** The turf area is established with slabs or rolls of sod. Sod should be laid in a brickwork arrangement. Roll the area to make good sod-soil contact. Keep the area moist for several weeks until grass is well rooted.

**Plugging:** Transplant small pieces of sod into holes the same size. Plugs can be either circular (1 to 2 inch diameter) or square (1 to 2 inch square) and are usually planted on 6 to 12 inch centers. Roll the area after planting with a weighted roller to establish good soil contact. Keep area moist until the plugs are well rooted and beginning to spread.

**Sprigging:** Fresh sprigs are runners with two to four nodes (joints). Plant the sprigs on 6-inch centers or in rows that are 12 inches apart with 4 to 8 inches between each sprig. Leave about one-quarter of each sprig above ground after planting. Roll the area to make good sod-soil contact. Keep area moist until the sprigs are well rooted and beginning to spread.

**Stolonizing (broadcast sprigging):** Broadcast stolons over the area to be established. Press them into the ground with a light disc and/or cover them with one-quarter inch of soil or similar material. Roll the area to make good sod-soil contact. Keep area moist until the stolons are well rooted and beginning to spread.

## Summary

A pest problem often results from improper selection or management of turfgrasses. The following is a brief checklist of cultural practices that affect turf vigor and pest invasion.

**Seed and sod:** Insect, disease and weed-free seed or sod is one of the first steps in pest control. Many turf areas have pest problems because they were present in the seed or sod or were not removed from the planting bed before seeding, sprigging or sodding.

**Improper mowing:** Mowing too short and not mowing often enough thins the turf, allowing weeds to get started. Mowing with a dull or improperly sharpened blade will damage and weaken a turfgrass. Mowing at the recommended height and proper frequency will encourage vigorous, dense, competitive turf.

**Improper watering:** Frequent and shallow watering encourages weed seed germination, disease, thatch and a shallow-rooted turf that is unable to compete with pests. Watering helps a turfgrass survive drought periods and maintain vigorous

growth. Water turfgrasses when they show signs of wilt, and then water to wet the soil to a depth of 6 inches or more.

**Improper fertilizing:** Fertilizing too much, too little or at the wrong time may benefit pests more than the grass. Fertilization programs that furnish turfgrasses with essential elements throughout the growing season tend to discourage pests through competition by a vigorous, healthy turf.

**Compacted soil:** Soil compaction is a hidden stress on the turfgrass root system. The reduction in available oxygen lowers the ability of the turfgrass to compete effectively with pests. Clay and silt soils are especially prone to compaction.

**Poor drainage:** The oxygen supply is depleted in poorly drained areas. Pests become a problem in these areas, especially those that thrive in waterlogged soils.

**Wrong turfgrass:** The wrong turfgrass for the location will gradually decline and be invaded by pests. Turfgrasses that are poorly adapted to the intended area or use cannot be expected to adequately compete with pests.

**Environmental stress:** Pests often take over a lawn after it has been weakened and thinned from stress caused by the weather. Allowing a turf to become stressed for extended periods is an open invitation for pest problems.

**Thatch:** Excessive thatch causes shallow-rooted grass and contributes to insect and disease problems, which are followed by weed invasion. Thatch also reduces the effectiveness of some soil-applied pesticides.

# Golf Course Weed Management

Arkansas lies in the turfgrass transition zone where turf managers sometimes come down with a condition known as “The Transition Zone Blues.” These “blues” occur because June, July and August can be just too hot and humid for bentgrass greens. Then, after you recover from summer, a “blue norther” blows in during January or February and kills your bermudagrass fairways. However, winterkill on bermudagrass greens is most common. Unless covered, Tifgreen, Tifdwarf, TifEagle or Champion putting surfaces may be damaged when temperatures drop below 25 degrees F. Due to greater mowing height, bermudagrass tees and fairways have more cold tolerance. We will have weather cold enough to kill bermudagrass about every five years. Shade, high traffic, poor drainage, compaction and excessively low mowing predispose bermudagrass to winter damage. Winterkill will show up along the shaded side of a fairway or at a point where all the carts leave the path and the soil is very compacted. Zoysiagrass fairways and tees tend to have excellent cold tolerance but present some other maintenance challenges.

Bermudagrass and zoysiagrass are the most widely adapted and commonly used golf course grasses in the state. Tall fescue (sometimes used for roughs) can be grown over the entire state but performs better in north Arkansas. Centipede grass, sometimes used for roughs, is best suited to the southern half of the state.

Most tees and fairways on Arkansas golf courses are bermudagrass (Common, Tifway, TifSport) or zoysiagrass (Meyer, Cavalier, El Toro). Putting greens are hybrid bermudagrass (Tifdwarf, Tifgreen, TifEagle, Champion) or creeping bentgrass (SR 1020, Crenshaw, PennCross, L-93, the A's and G's and many others). Roughs range from tall fescue to bermudagrass, zoysiagrass, weeping lovegrass, centipedegrass and many native grasses. Perennial ryegrass and rough bluegrass are most often used for winter overseeding of bermudagrass turf.

Golf course weed control is complicated by a high level of foot and vehicular traffic resulting in turfgrass compaction and wear. This damage thins the turf opening it up for weed invasion. In addition,

mowing heights on golf courses are lower than many other turf sites, which often results in turf with a limited root system. Turfgrass with a diminished root system has less recuperative potential and is slower to recover from herbicide injury.

Putting greens are the most sensitive to herbicides followed by tees, fairways and roughs. Weed management in bentgrass is more difficult because it is being grown on the edge of its range of adaptation and it is often barely hanging on during summer stress periods. Annual bluegrass is often the number one weed of bentgrass putting greens. Superintendents are left with the difficult problem of removing a cool-season grass from a cool-season grass. Another major problem on bentgrass greens is encroachment of bermudagrass and occasionally zoysiagrass from the collar. There is no easy cure for this problem or annual bluegrass.

Kyllinga, goosegrass and smooth crabgrass are fairly common on greens but much easier to control than *Poa* or bermudagrass encroachment.

Goosegrass, dallisgrass, crabgrass and sedges can be a problem on tees and high traffic parts of fairways. Virginia buttonweed, annual sedge, globe sedge, yellow and purple nutsedge and kyllingas favor low areas that remain wet during the growing season. Winter annuals such as annual bluegrass, henbit, chickweed, field madder, Carolina geranium, bittercress and shepherd's purse are common to fairways and roughs.

## Turfgrass Weeds

If there were no humans, there wouldn't be any weeds. There are no weeds in nature. Good or bad, we decide which plants are weeds. Opinions as to what is a weed vary widely. Divergent viewpoints on this matter have given rise to the observation that one person's weed is another's wildflower. Typically, a weed is a plant growing where someone doesn't want it. Violets may be desirable in an ornamental bed but are often considered a weed when growing in a lawn. Bermudagrass in a pure stand is a turfgrass but is considered a weed when growing in a zoysiagrass turf. Turfgrass weed control is usually concerned with maintaining the uniformity of

the stand. But there are other reasons to control turfgrass weeds: competition with turfgrass, hard to mow plants, spiny plants and that clump of goosegrass that ruins your birdie putt on No. 17.

## Sources of Turfgrass Weeds

Most turfgrass weeds result from seeds found in the soil. The number of weed seeds in the soil seed bank varies widely. Documented counts of viable seed from one square yard and a 10-inch depth range from a low of 250 to a high of 130,000. The old saying, “one year’s seeding—seven year’s weeding,” is pretty accurate. Some seeds may remain inactive for several years and then emerge under favorable temperature, light and moisture conditions. These weeds generally germinate and mature when bare spots develop or if the soil is disturbed. Topsoils, manures and composts usually contain an abundance of weed seed. A new crop of weeds can be expected whenever these amendments are used.

Weed seeds may be transported from place to place by a variety of methods. Dandelion seeds are carried many miles by the wind. The tacky seeds of plantain are transported by clothing, equipment and animals. Ripe seedpods of yellow wood sorrel can explode and throw their seeds many feet. Moving weeds on sod is a common means of introducing weeds. Turfgrass managers should inspect sod prior to purchase to make sure it is free of problem weeds. Three difficult-to-control weeds that are commonly moved with sod are bermudagrass, Virginia buttonweed and nutsedge. The introduction of weeds from ornamental plantings is also common. Ornamental containers are an excellent way to transport weeds over long distances. Chamberbitter made its way to Arkansas in container ornamentals. Other species such as yellow nutsedge, oxalis and bittercress are commonly found in containers.

## Reasons for Weed Invasion

Weed invasion is often the result of weak ened turf rather than being the cause of it. Weed encroachment occurs in bare spots or areas of thin turf. There are a multitude of reasons for weak turfgrass including: (1) turf species not adapted to the environmental conditions; (2) damage from turfgrass pests such as insects, diseases, nematodes and animals; (3) environmental stresses such as

excessive shade, drought, heat and cold; (4) poor turf management practices such as misuse of chemicals and fertilizer, improper mowing height, frequency and incorrect soil aeration; and (5) physical damage and compaction from concentrated traffic. Unless these fundamental causes of weed problems are corrected, weed invasion will continue. The presence of certain weed species may be an indicator of specific environmental conditions.

Weeds as Indicators of Specific Conditions	
Condition	Indicator Weed(s)
Low pH	red sorrel
Soil compaction	goosegrass, knotweed, <i>Poa annua</i> , path rush
Low nitrogen	legumes: clover, lespedeza
Poor (sandy) soils	sandbur, poorjoe
Poor drainage	sedges, rushes
Surface moisture	algae
High pH	plantains
High nematode populations	prostrate spurge, knotweed
Low mowing	algae

## Developing a Weed Control Program

There are several important considerations when developing a weed control program.

1. Know what kinds of turfgrass you have and the total area of each different type.
2. Identify the problem weeds and note what time of the year they occur.
3. Determine why the weeds invaded the turf area and correct the conditions or cultural practices that caused the problem.
4. When an herbicide is needed:
  - Select a chemical that is effective for the weeds and safe for the turfgrass.
  - Follow all label directions.
  - Apply the herbicide at the correct time and rate.

- Apply the herbicide uniformly over the turf area without skips or overlapping.
  - Repeat the herbicide application when specified on the label.
5. Follow a good turf management program along with the weed control program. An integrated approach that includes enhancing turfgrass competition, mechanical control and chemical control methods will be the most successful weed control program.

## Weed Identification Is a Fundamental Skill

The importance of weed identification skills is obvious. It is impossible to look for control information until the weed has been identified. The ability to identify weeds is important from more than a control standpoint. Often, the first question a client is going to ask is, “what is that weed?” So, weed identification is also useful in establishing your credibility as a professional.

**Weed identification should begin with classifying weeds by type. The four most common weed types are grasses, broadleaves, sedges and rushes.**

**Grasses** are a monocotyledonous plant, which means they have only one seed cotyledon (leaf) present when a grass seedling emerges from the soil. Grasses have joints (nodes) and hollow, rounded stems. The true leaves (as opposed to seed or cotyledon leaves) have parallel veins and are several times longer than they are wide. Crabgrass, goosegrass, dallisgrass and annual bluegrass are typical grass weeds found in turf.

**Broadleaf** weeds are dicotyledonous, which means they have two cotyledons at emergence and have net-like veins in their true leaves. Broadleaves often have colorful flowers compared to the inconspicuous flowers found on grasses. Chickweed, henbit, lespedeza, clover, dandelion and dock are typical broadleaf weeds.

**Sedges** have solid, triangular stems (in most species) which bear leaves extending in three directions (three-ranked). Sedges lack ligules and auricles, and the leaf sheath is continuous around the stem. Yellow and purple nutsedge, rice flatsedge and globe sedge are examples.

**Rushes** have round, solid stems and favor a moist habitat. Path rush is an example of the rush family. Path rush is often found on golf cart routes, sports fields and other compacted areas.

Not all turfgrass weeds fall into these categories. Some turfgrass weeds are monocotyledonous plants but are not sedges or grasses. Some examples are wild garlic, false garlic and star-of-Bethlehem, which are members of the **lily family**.

## Weed Life Cycles

The previously listed weed classifications may be further divided into annuals, biennials and perennials. **Annuals** germinate from seed, grow, mature and die in less than 12 months. Annuals may be further classified as winter and summer annuals.

**Winter annuals** germinate in the fall, grow during cool periods, mature in the spring and then die during the summer. **Summer annuals** germinate in the spring, grow actively during the summer and die in the fall. Crabgrass and goosegrass are examples of summer annual grasses. Annual blue grass is our most common winter annual grass weed in turf. Prostrate knotweed is an example of a summer annual broadleaf, while henbit and chickweed are representative of winter annual broadleaves.

**Biennials** reproduce from seed and complete their life cycle in two years. Biennials form rosettes and store food in their fleshy roots the first year and then flower the second year. Many thistle species in Arkansas are biennials.

**Perennial** weeds live more than two years. Perennials may reproduce from seed or from vegetative structures such as roots, rhizomes, stolons, tubers, or bulbs. The ability to reproduce vegetatively makes perennials more difficult to control. Some perennials such as dandelion, dock and wild garlic are actively growing during cool weather, while others like dallisgrass and nutsedge grow rapidly during the summer months. Perennials are further subdivided as simple perennials and creeping perennials. **Simple perennials**, such as dock and dandelion, overwinter by means of a vegetative structure such as a perennial root with a crown, but they reproduce almost entirely by seed. **Creeping perennials** can both overwinter and produce new independent plants from vegetative reproductive structures. Vegetative reproductive structures include creeping roots, stolons

(bermudagrass), rhizomes (johnsongrass), tubers (nutsedge) and bulbs (wild garlic). Most perennials can also reproduce from seeds.

If you are serious about turfgrass weed control, a guide to weed identification is a very useful tool. Some recommended publications may be found in the section “Selected Turfgrass References and Study Material.”

## Principles of Herbicide Use

Before selecting any herbicide, determine whether or not the desirable turfgrass is tolerant of the chemical being considered. The majority of turfgrass herbicide failures result not from the weakness of the herbicide but from (1) choosing the wrong herbicide, (2) applying at the wrong time, (3) treating a turfgrass species that is susceptible to the herbicide, (4) poor calibration, (5) lack of uniform application, (6) unsuitable application equipment, (7) insufficient agitation, (8) wrong growth stage of the target weed and (9) undesirable environmental conditions at the time of application.

## Herbicide Names

Herbicide labels contain three names: trade name, common name and chemical name. The nomenclature for Roundup Pro is **trade name** – Roundup Pro, **common name** – glyphosate, **chemical name** – N-(phosphonomethyl)glycine. The trade name is used by the chemical company to market the product and is often the most recognizable name. The common name is a generic name given to a specific chemical. Only one common name exists for each herbicide. It is useful to be familiar with common names when comparing products. The chemical name describes the chemistry of the herbicide. To make things confusing, the same or different chemical companies often sell the same herbicide under different trade names. For example, DuPont markets metsulfuron for pasture use as Cimarron and for forestry use as Escort. Metsulfuron is sold for use in turfgrass by Rival as Manor and by PBI Gordon as Blade.

## Herbicide Terminology

**Selective.** A selective herbicide controls or suppresses some plant species without seriously affecting the growth of another plant species. Selectivity may be due to differential absorption,

translocation, morphological and/or physiological differences between turfgrasses and weeds. Most turfgrass herbicides are selective. 2,4-D is an example of a selective herbicide that controls many broadleaf weeds without causing significant injury to grasses. Selective is a relative term that depends of many factors that include herbicide rate, environmental conditions, timing of application and the desirable species and variety being treated.

**Nonselective.** Nonselective herbicides control or suppress plants regardless of species. Glyphosate (Roundup), glufosinate (Finale) and diquat (Reward) are examples of nonselective herbicides. These products are often used for trimming along sidewalks and fences and as preplant treatments when renovating or establishing turfgrass. It is important to note that the selectivity of some herbicides is based on rate. Increasing the rate of a selective herbicide such as atrazine will move it into the nonselective category.

**Mode of action** refers to the sequence of events that includes herbicide absorption, translocation to the site(s) of action, inhibition of a specific biochemical reaction, the degradation or breakdown of the herbicide in the plant and the effect of the herbicide on plant growth and structure.

## Herbicide Movement in the Plant

**Systemic** (sometimes referred to as translocated) herbicides are extensively translocated in the vascular system of the plant. The vascular system consists of the xylem and phloem. The xylem transports water and various nutrients in solution, upward from the roots where they entered the plant, through the stems and into leaves, flowers, and fruits. The phloem conducts food materials from their principal sites of synthesis in leaves to other locations, such as fruits and developing roots, for storage and use. Systemic herbicides are slower acting than contact herbicides because they require from several days to a few weeks to move throughout the vascular system of a treated plant. Systemic herbicides may be selective or nonselective. Glyphosate (Roundup) is an example of a nonselective systemic herbicide, while 2,4-D, dicamba (Vanquish), imazaquin (Image) and sethoxydim (Vantage) are examples of selective systemic herbicides.



**Contact** herbicides affect only the green plant tissue that comes in contact with the herbicide spray. Thus, thorough coverage of the weed foliage is needed to achieve optimum control. These herbicides are either not translocated or only move to a limited extent within the vascular system of plants. For this reason, underground vegetative reproductive structures, such as roots, rhizomes and tubers, are not affected. Multiple applications of contact herbicides are needed for long-term control because plants regrow from these unaffected plant parts. Contact herbicides are fast acting. Symptoms are often visible within a few hours of application. Bromoxynil (Buctril) and bentazon (Basagran T/O) are selective contact herbicides. Diquat (Reward) and glufosinate (Finale) are nonselective contact herbicides.

## Timing of Application

Herbicides are also classified by when the chemical is applied relative to turfgrass and/or weed seed germination. The majority of herbicides may be classified into one of three timing categories: preplant, preemergence or postemergence. However, atrazine (Aatrex), simazine (Princep), dithiopyr (Dimension) and pronamide (Kerb) are exceptions. They are used as preemergence and postemergence herbicides.

## Preplant Herbicides

These herbicides are applied before turfgrass is established to make the site as weed-free as possible. Glyphosate (Roundup) is often used as a preplant herbicide. On high-value sites, such as putting greens, soil fumigants such as methyl bromide, metam-sodium or dazomet are used as preplant herbicides.

## Preemergence Herbicides

Preemergence herbicides are the foundation of a turfgrass weed management program. Preemergence herbicides are applied to the site before weed seed germination. After being activated by rainfall or irrigation, these herbicides form an herbicide barrier at or just below the soil surface. When the roots or shoots of germinating seeds come in contact with the herbicide barrier, their growth is inhibited. Most preemergence herbicides are cell division inhibitors affecting the emerging root and shoot, which are sites of rapid cell division. Weeds that have already emerged (visible) are not consistently controlled because their growing point has escaped contact with the herbicide. The primary target of preemergence herbicides is annual grass, but some small-seeded annual broadleaves will be controlled.

A variety of factors affect the performance of preemergence herbicides. These include timing of application in relation to weed seed germination, soil type, environmental conditions (primarily temperature and rainfall), target weed species and biotype and cultural factors (core aeration, for example) that follow application.

All of the products listed in the table below are characterized by long soil persistence, low water solubility and strong adsorption to organic matter. As a result, when they are applied to turfgrasses and activated by water, a very thin herbicide barrier is formed. As the weeds start to germinate, the young seedling comes into contact with the herbicide, absorbs the herbicide and the young seedling dies. It is, therefore, very important to apply the herbicide and water it in prior to seed germination if maximum results are to be obtained. Activation of preemergence herbicides requires 0.25 to 0.5 inch of

<b>Major Preemergence Crabgrass and Goosegrass Herbicides</b>			
<b>Trade Name(s)</b>	<b>Common Name</b>	<b>Family</b>	<b>Mode of Action</b>
Barricade	Prodiamine	Dinitroaniline	Mitotic inhibitor
Pendulum, Pre-M	Pendimethalin	Dinitroaniline	Mitotic inhibitor
Surflan	Oryzalin	Dinitroaniline	Mitotic inhibitor
Team Pro	Trifluralin + benefin	Dinitroaniline	Mitotic inhibitor
XL	Oryzalin + benefin	Dinitroaniline	Mitotic inhibitor
Dimension	Dithiopyr	Pyridine	Mitotic inhibitor
Ronstar	Oxadiazon	Oxadiazole	Disrupts cell wall synthesis

rainfall or irrigation. For optimum performance, rainfall or irrigation should occur within 24 hours of application to move the herbicides into the upper layer of the soil. The critical period between application and activation by rainfall or irrigation varies with herbicide, rate and environmental conditions.

Ideally, preemergence herbicides should be applied just before weed seed germination begins. Applying too early may result in reduced control or no control due to leaching and/or normal herbicide degradation. However, there is a good deal of research that indicates preemergence summer annual grass control applications may be made as early as January. The reason this works is that during cool weather the rate of herbicide degradation is slow and most of the preemergence grass herbicides do not leach readily. Applying early (January-February) is often a must for lawn care companies because a period of several weeks is required to service all of their customers. Preemergence herbicides must be in place and activated before weed seed germination begins.

Crabgrass germinates in the spring (late March-April) when soil temperature at the 4-inch depth reaches 53 to 58 degrees F. Alternating wet and dry conditions at the soil surface as well as light encourage crabgrass germination. Goosegrass germinates at soil temperatures of 60 to 65 degrees F. Goosegrass also requires light for germination and is very competitive in compacted, heavy traffic areas with thin turf. Because warmer temperatures are required, goosegrass typically germinates about two to four weeks later than crabgrass. Thus, when targeting goosegrass only, it is a mistake to apply preemergence herbicides at the crabgrass timing. Apply preemergence herbicides for goosegrass control two to three weeks later than the crabgrass application date.

## Sequential or Repeat Applications

In warm weather, herbicides begin to degrade soon after application, eventually reaching a level at which weed seed germination can occur. Preemergence herbicides will degrade to the point of ineffectiveness from 6 to 16 weeks after application. For this reason, repeat or sequential applications are needed for full season control.

## Core Aerification and Preemergence Herbicides

For years it was assumed that core aerification would disrupt the herbicide barrier in the soil and result in weed seed germination. However, research has shown that core aerification of 'Tifgreen' and common bermudagrass did not stimulate crabgrass germination when done immediately before application and one, two, three or four months after treatment. An exception to this occurred with creeping bentgrass where greater amounts of crabgrass occurred where cores were returned compared to sites not aerified or aerified with the cores removed.

The most common reason for disruptions in the herbicide barrier is a lack of uniform herbicide application. Poor application of a spray or a granular product can lead to large, untreated areas that result in weed outbreaks. Poorly formulated granular products may prevent uniform distribution of the herbicide. The two most common problems of granular herbicides are excessively large particle size or a lack of uniform particle size. Big particles result in fewer particles per square foot and thus less coverage. A mixture of many particle sizes will prevent uniform distribution because heavy particles will behave differently than light particles when dropped on the spreader rotor. The data in the table below illustrates this point. Two experimental formulations of Barricade were compared to the spray formulation. The most concentrated granular product 0.5% granular formulation resulted in fewer particles per square foot compared to the more dilute 0.29% formulation. Note that the 0.29 G outperformed the 0.5 G. This was due to incomplete coverage by the 0.5 G. Remember that most of the preemergence herbicides are largely immobile in the soil.

Preemergence Control of Smooth Crabgrass With Various Barricade Formulations		
Barricade Formulation	Rate: lbs ai/ac	% Control
Barricade 65 WDG	0.75	98
Barricade 0.5 G	0.75	81
Barricade 0.29 G	0.75	91
LSD 0.05		9.3
Applied March 4, 1996, and rated September 26, 1996.		

## Other Preemergence Considerations

The majority of preemergence herbicides (dinitroanilines often referred to as DNAs) used in turfgrass weed control are mitotic inhibitors that interfere with cell division. These materials are intended for use on established stands of grass. Plan ahead when using preemergence herbicides and do not treat areas where new turfgrass is to be established. The same precaution applies to established turf that is to be overseeded. Examples include tall fescue lawns that are to be overseeded in the fall and warm season grasses that are to be overseeded with a cool season grass. The waiting period before planting is typically two to four months. There are exceptions to this rule when the objective is *Poa annua* control in overseeded ryegrass. Planting too soon following a preemergence treatment may result in reduced germination of seeds or root inhibition of sod, sprigs or plugs. Dimension is in a different herbicide family (Pyridines) but has the same root-inhibiting mode of action as the dinitroanilines.

In heavily trafficked areas, bare spots or thin stands, it is often wise to skip applications of preemergence herbicides that are mitotic inhibitors until the grass has recovered. Ronstar (oxadiazon), which is not a mitotic inhibitor, is a good choice for preemergence control of annual grasses on high traffic sites such as par 3 tees. This is why Ronstar is the preemergence herbicide of choice for weed control when sprigging. In tolerant grasses, MSMA is a postemergence alternative for these situations. The disadvantage is temporary turfgrass injury from MSMA.

## Preemergence Herbicide Use

Recommended dates of application for control of crabgrass and other summer annual grasses are February 15-March 5 for southern Arkansas and March 1-20 in northern Arkansas. Goose grass usually germinates about two weeks later than crabgrass. Apply preemergence herbicides for annual bluegrass control on September 1. Herbicides such as atrazine (Aatrex) and simazine (Princep) may be applied in November or December because they will control small annual bluegrass postemergence. A good window to shoot for when using simazine for winter weed control is the period between Thanksgiving and Christmas. Preemergence

herbicides should be watered-in immediately after application. Herbicide-only formulations have been the standard for many years, but the practice of impregnating herbicides on dry fertilizer granules is becoming increasingly popular. Common sense suggests that choosing a fertilizer carrier with relatively uniform particle size will improve the uniformity of herbicide distribution. Another factor to consider when using herbicide + fertilizer products for summer annual grass control is that warm season grasses are dormant at the time of the first application so much of the fertilizer will be wasted. These products are better used for the second application in May or June when warm season grasses can use nitrogen fertilizer. When using fertilizer/herbicide combinations, consider whether or not the herbicide/nutrient ratio is right for the turfgrass and the environmental conditions.

## Postemergence Herbicides

Postemergence herbicides are intended for use on weeds that have germinated and are visible. They are applied directly to emerged weeds. In contrast to preemergence herbicides, most postemergence herbicides have little or no soil activity. It is possible to conduct a total postemergence weed control program in turfgrass provided multiple applications are used throughout the year. The primary advantage of total postemergence control is that it is possible to wait and see if weeds emerge and whether it is necessary to treat. Disadvantages of total postemergence weed control include the need for frequent applications and, in some cases, temporary turfgrass injury. Most turfgrass managers use a combination of preemergence and postemergence herbicides. Preemergence herbicides form the basis of most programs with postemergence herbicides used to control weeds that escape the preemergence treatments. Established perennial weeds, both grasses and broadleaves (dallisgrass, nutsedge, Virginia buttonweed, white clover, plantain) must be controlled with postemergence herbicides. Some postemergence herbicides may be used on newly established grasses.

General guidelines for postemergence applications are small weeds, good soil moisture and air temperatures between 60 and 90 degrees F. Postemergence herbicides applied at temperatures below 60 degrees F are often effective; however, more time is required for the herbicide to kill the weeds. Annual weeds that are small (two- to

four-leaf stage) and actively growing are much easier to control with postemergence herbicides. Control is improved at this stage because young weeds readily absorb and translocate herbicides. Early weed control accompanied by fertilization also provide an opportunity for stoloniferous turfgrasses (bermudagrass, centipedegrass, St. Augustinegrass, zoysiagrass) to fill in the bare areas left by removing the weeds.

Weeds that are stressed due to dry weather, heat or other environmental factors (dust-covered leaves) are more difficult to control with postemergence herbicides. Applying herbicides such as MSMA, DSMA, 2,4-D, mecoprop, dichlorprop and dicamba at temperatures above 90 degrees F increases the risk of turfgrass injury.

The resistance of postemergence herbicides to wash-off by rainfall or irrigation varies among products. Typically, a rain-free period of 6 to 24 hours is sufficient to avoid a reduction in effectiveness. Even if rain falls soon after application, some degree of reduced control will be achieved.

Mowing can affect performance of postemergence herbicides. Avoid mowing one to two days before application to allow development of greater leaf area to intercept the spray. Delay mowing one to two days after spraying to provide time for the herbicide to be absorbed and translocated.

Follow the label when using surfactants and crop oil concentrates with postemergence herbicides. Do not add surfactants that are not required because the result may be increased turfgrass injury. In situations where there is good soil moisture, warm temperatures and high humidity, the benefits of surfactants may not be obvious. However, under marginal environmental conditions, failure to use the proper additive may result in reduced weed control.

Rather than a single rate, a range of postemergence herbicide rates for a product usually is given. Repeat applications of a moderate rate are generally more effective than a single application of the higher rate. The follow-up application is timed to be 7 to 14 days after the first or when regrowth appears. For example, for bermudagrass control it is much more effective to apply Roundup three times at 2 quarts/A (waiting for regrowth between each application) compared to applying one time at 6 quarts/A.

If possible, avoid using postemergence herbicides during the spring green-up or transition period of warm season turfgrasses. It is preferable to treat either completely dormant or actively growing grasses. Applying products such as Confront and to a lesser extent Trimec will cause yellowing and stunting of bermudagrass and zoysiagrass that is in transition.

## Broadleaf Weed Control

Phenoxy (2,4-D, dichlorprop, MCPA, mecoprop) and benzoic acid (dicamba) herbicides have traditionally been the backbone of broadleaf weed control programs in turfgrass. These are selective, postemergence, foliar-applied herbicides. Rarely applied alone, these materials are typically used in two- and three-way combinations to broaden the spectrum of control. For perennials and tough annuals, repeat applications of these combination products 10 to 14 days apart are often needed for acceptable weed control. Overseeded ryegrass needs to be mowed three to four times before treatment with three-way phenoxy herbicides.

Over the last few years, some alternatives to the phenoxy herbicides for broadleaf weed control have been labeled for use in turfgrass. Triclopyr (Turflon II, Turflon Ester, others) and clopyralid (Lontrel) are now commonly used alone and in combination for postemergence broadleaf weed control. Triclopyr is a good alternative to try when the traditional three-way products (2,4-D + dicamba + MCPA) do not provide control. Triclopyr and clopyralid belong to the carboxylic or picolinic acid family of herbicides and produce symptoms very similar to the phenoxy herbicides. Clopyralid has very good turf safety on cool and warm season grasses but has a narrow range of control limited to the sunflower (Asteraceae) and legume (Fabaceae) families. Clopyralid is excellent on white clover and other legumes, thistles and other members of the Asteraceae. Confront (triclopyr + clopyralid) has a broader spectrum and is useful on hard-to-control broadleaves. Care must be taken to avoid overdosing when using triclopyr on warm season grasses. In fact, Turflon Ester (triclopyr ester) is labeled for suppression of bermudagrass in cool season turfgrasses.

Metsulfuron (Manor, Blade) is a member of the sulfonyleurea family of herbicides. It is an effective product for controlling many species of

broadleaf weeds in bermudagrass, zoysiagrass, St. Augustinegrass and centipedegrass. Chlorsulfuron (Corsair) is also a member of the sulfon ylurea family of herbicides. Corsair controls some broadleaf weeds but does not have the broad control spectrum of metsulfuron.

## Grass Control in Bermudagrass and Zoysiagrass

The organic arsenicals (MSMA, DSMA, CMA) have been the standard for postemergence grass weed control in tolerant turfgrass species for many years. Two to four applications spaced 7 to 10 days apart are generally needed for satisfactory control. The rate and number of applications generally increases as weeds mature. Control is also reduced if rainfall or irrigation occurs within 24 hours of treatment.

Alternatives to MSMA have appeared in the marketplace over the past few years. The following section describes postemergence grass herbicides suitable for use on various turfgrass species.

MSMA has been the primary herbicide for postemergence control of crabgrass. Repeat applications with a short time interval between applications are required for control of mature crabgrass. MSMA is not effective for goosegrass or tufted lovegrass control. Dallisgrass control requires five applications of MSMA at weekly intervals. This treatment is limited to use on bermudagrass. Tank mixing low rates of Sencor (metribuzin) with MSMA improves goosegrass control in bermudagrass. Adding metribuzin to MSMA also increases bermudagrass injury, but the bermudagrass will recover quickly under good growing conditions. Do not use Sencor on zoysiagrass. MSMA + metribuzin should be limited to established, actively growing bermudagrass that is being maintained at a mowing height of 0.5 inch or greater.

Drive (quinclorac) is an effective herbicide for control of crabgrass, barnyardgrass and broadleaf signalgrass in bermudagrass and zoysiagrass. Do not use Drive on centipedegrass or St. Augustinegrass. Drive also controls some broadleaf weeds such as white clover and dandelion. It may be tank mixed with MSMA to improve the spectrum of control. Drive will not control

goosegrass. Drive is much safer for crabgrass control in cool season grasses than MSMA.

Diclofop (Illoxan) has shown excellent goosegrass control under the right conditions. Illoxan causes little turfgrass injury, and retreatment is usually not needed. This herbicide is more effective on younger, lower-mowed goosegrass (0.5 inch less mowing height). It is a slow-acting herbicide usually requiring two to three weeks for control. Illoxan has little effect on other turfgrass weeds. Treated areas should not be overseeded with ryegrass for six weeks following application. Do not tank mix Illoxan with other pesticides.

Fenoxaprop (Acclaim Extra) will control crabgrass in zoysiagrass and tall fescue. The crabgrass should be treated while it is very small (less than 4 leaf). Acclaim Extra may also be used for bermudagrass suppression in zoysiagrass and tall fescue. Three to four applications of Acclaim Extra per year over a two-year period are needed to provide significant bermudagrass suppression. Eradicating bermudagrass from zoysiagrass with Acclaim Extra requires a long-term effort.

Sethoxydim (Vantage) is approved for use in centipedegrass. Apply Vantage to centipedegrass to control annual grasses and suppress bermudagrass and bahiagrass. Do not make more than two applications per season. Clethodim (Envoy, Select) is also safe to use on centipedegrass but is not currently labeled in Arkansas.

Fluazifop (Fusilade II) may be used on tall fescue (3 to 6 fluid ounce/A) and zoysiagrass (3 to 5 fluid ounce/A) to suppress bermudagrass and control annual grass weeds. Eradicating bermudagrass from zoysiagrass with Fusilade II is a difficult proposition that requires persistence.

Ethofumesate (Prograss) has been approved for bermudagrass suppression in St. Augustinegrass. Research indicates that tank mixing with atrazine and using multiple applications will improve the level of control.

Tranxit (rimsulfuron) may be used on zoysiagrass and bermudagrass for control of cool season grasses, such as annual bluegrass, rough bluegrass, perennial ryegrass and tall fescue. It is not for use on residential lawns. Tranxit may be used on bermudagrass that has begun to green up. Do not

apply to slopes that drain onto cool season grasses, such as bentgrass greens or ryegrass overseedings.

Revolver (foramsulfuron) may be used on zoysiagrass and bermudagrass for control of cool season grasses such as annual bluegrass, rough bluegrass, perennial ryegrass and tall fescue. Use only on sod farms and golf courses. Revolver provides some control of goosegrass and dallisgrass, but the research data is insufficient at this time. Revolver may be used on bermudagrass that has been green-up. Do not apply to slopes or drain onto cool season grasses such as bentgrass greens or ryegrass overseedings.

Kerb (pronamide) is used for annual bluegrass control in bermudagrass and for aiding in transition of bermudagrass overseeded with ryegrass. It has both pre- and postemergence activity but works very slow taking up to six weeks for control. Kerb should be watered in after application. Manor (metsulfuron) is also used for ryegrass to bermudagrass transition. Do not apply Kerb or Manor to slopes or drain onto cool season grasses such as bentgrass greens or ryegrass overseedings.

Roundup Pro (glyphosate) at one pint per acre is a cheap and effective way to control annual bluegrass in completely dormant bermudagrass.

## Grass Control in Cool Season Turfgrasses

Postemergence grass control in cool season grasses with organic arsenicals such as DSMA or MSMA is risky due to the high probability of unacceptable levels of injury. These products can be very damaging to cool season grasses, such as tall fescue, especially during hot weather.

Drive (quinclorac) is an effective herbicide for control of crabgrass, barnyardgrass and broadleaf signalgrass in tall fescue, Kentucky bluegrass, perennial ryegrass and bentgrass fairways. Drive also controls some broadleaf weeds such as white clover and dandelion. Drive has become one of the dominant postemergence grass herbicide in cool season grasses.

Fluazifop (Fusilade II) may be used on tall fescue to control annual grassy weeds and suppress bermudagrass. Apply when weeds are small and before the onset of hot weather stress.

Sethoxydim (Vantage) at 2.4 pints per acre controls many annual grasses in fine fescue. Spring applications are most effective when weeds are small and the weather is cool.

Corsair (chlorsulfuron) controls tall fescue selectively in Kentucky bluegrass and fine fescues. Low rates (1 to 5 ounces/A) help to reduce turf injury.

Fenoxaprop (Acclaim Extra) at 13 to 39 fluid ounces/A may be used on Kentucky bluegrass, fine fescues, tall fescue, annual bluegrass, perennial ryegrass and bentgrass fairways to control most annual grass weeds and to suppress bermudagrass encroachment. Apply in the spring when the turf is not under stress. Acclaim Extra may be tank mixed with Turflon Ester for improved suppression of bermudagrass in tall fescue.

## Annual Bluegrass (*Poa annua*)

Annual bluegrass can be mowed at a height of 1/8 inch and still produce seed. It thrives in compacted soils, grows well in wet soils and can produce over 2,000 seeds per plant. While weed scientists agree that the majority of annual bluegrass seeds germinate in the early fall, recent research at Auburn University has shown that a small percentage of annual bluegrass seed can germinate at the high air temperatures of summer, indicating its ability to germinate year round. Another problem with annual bluegrass control is that it exists as both an annual and perennial biotype. *Poa annua* var. *annua* is classified as the true annual biotype that dies in the late spring months, while *Poa annua* var. *reptans* is classified as a perennial that can survive high summer air temperatures under management regimes used to maintain creeping bentgrass putting greens. Syringing and fungicide use that ensures creeping bentgrass survival in the South also promotes the survival of the perennial biotype of annual bluegrass.

Research proves that both preemergence and postemergence herbicides can control annual bluegrass in most turfgrass sites. Application timing with preemergence herbicides is critical to achieving high levels of control. Annual bluegrass starts its primary period of germination in late summer and early fall when soil temperatures at the 4 inch level drop to the low- to mid-70 degree F ranges (or lower). Preemergence herbicide application should

be timed just prior to expected period of peak germination. Annual bluegrass often has a second germination flush in mid- to late winter. This is important for turf managers to recognize because fall herbicide applications normally do not provide season-long control, and repeat applications may be necessary.

Herbicide research repeatedly shows that the majority of preemergence herbicides labeled for use in turfgrasses will provide 80 to 90 percent control of annual bluegrass when applied according to label directions. Similarly, postemergence applications of atrazine, simazine and pronamide (Kerb) during November-February will provide high levels of annual bluegrass control in non-overseeded warm-season turfgrasses. In addition to bermudagrass, Kerb is now labeled for use in centipede grass, zoysiagrass and St. Augustine grass. For best results with Kerb, it should be applied during the cool winter months and watered in with 0.25 inch of irrigation water within 24 hours of application. Kerb is root-absorbed; thus, adequate water is necessary to move Kerb into the root zone and prevent volatilization. Kerb is highly phytotoxic to cool season turfgrasses and should not be applied to overseeded warm season turfgrasses or adjacent to cool season turfgrass sites.

Two new annual bluegrass control options are TranXit (rimsulfuron) and Revolver (foramsulfuron). These herbicides are for annual blue grass control in overseeded and non-overseeded bermudagrass. TranXit and Revolver are sulfonylurea herbicides that have primarily postemergence activity on annual bluegrass. TranXit and Revolver are also labeled for use as a spring transition aid. Late spring applications of TranXit or Revolver at approximately the 50 percent green-up growth stage of bermudagrass will control perennial ryegrass with only slight injury to bermudagrass. Under no circumstances should TranXit or Revolver be applied to control annual blue grass in desirable fall-seeded, cool-season turfgrasses or to creeping bentgrass.

## Herbicide Formulations

The two big groups of herbicide formulations are dry and liquid. The amount of active ingredient in a dry formulation is designated as a percent of the weight. The active ingredient in liquid forms is listed in pounds per gallon. Within the dry

formulations, there are granular or pelletized herbicides that are spread directly on the target in their dry form. These products usually contain very low percentages of active ingredient (0.1% to 2.0%) and are designated by the abbreviation **G** or **GR** (granule) or **P** (pellet). Other dry formulations are mixed with water and sprayed on the target. These products are designated as **SP** (soluble powder), **W** or **WP** (wetable powder), **WSP** (water soluble packet), **DF** (dry flowable), **SG** (soluble granule) or **WG, DG** or **WDG** (water dispersible granule). Liquid formulation designations include **L** or **F** (liquid suspension), **E** or **EC** (emulsifiable concentrate), **SC** (suspension concentrate), **SL** (soluble liquid), **ME** (microencapsulated) and **CS** (capsule suspension).

Some herbicide formulations may be incompatible. MSMA and 2,4-D amine will sometimes form sludge when mixed. Liquid nitrogen and 2,4-D amine will always form sludge when mixed. One way to avoid a big mess is to combine a small amount of each herbicide in a jar with water, shake and see what happens. In addition to physical incompatibility, two herbicides may mix well but may be chemically incompatible resulting in a reduction in herbicide activity. For example, mixing 2,4-D with Fusilade, Vantage or other grass specific herbicides will result in decreased grass control. This is referred to as antagonism. The label will give instructions on what can and cannot be mixed with that herbicide. When tank mixing different formulations: (1) fill the tank two-thirds full of water, (2) start the agitation and keep it running and (3) add the respective formulations in this order: wettable powders > dry flowables > liquid suspensions > emulsifiable concentrates > soluble concentrates.

## Herbicide Spray Additives and Their Uses

**Adjuvant** – any additive used with an herbicide that enhances the performance or handling of the herbicide.

**Compatibility agent** – a material that allows the mixing or improves the suspension of two or more formulations when applied together as a tank mix. They are used most frequently when a liquid fertilizer is the carrier solution for an herbicide.

**Crop oil concentrate** – oil-based material that enhances herbicide penetration through the leaf cuticle.

**Defoamer** – a material that eliminates or suppresses foam in the spray tank so that pumps and nozzles can operate correctly.

**Drift control agent** – a material used in liquid spray mixtures to reduce spray drift.

**Fertilizer** – certain fertilizers added to the spray tank can enhance penetration of the herbicide into the leaf.

**Surfactant** – a material that improves the emulsifying, dispersing, spreading, wetting or other surface-modifying properties of liquids.

**Wetting agent** – a material that reduces interfacial tensions between water droplets and the leaf cuticle.

## Herbicide Management

Remember that herbicides can injure nontarget or desirable plants. When using any herbicide, manage the application carefully. Take steps to ensure that herbicides are directed to the target. Use them at the proper rate, at the right time and on a site that the label permits. Control each application so there is no off-target movement. Off-target movement may result from drift of actual spray droplets, volatilization and surface runoff water or by tracking with feet or equipment. One way to avoid injury to desirable plants is to apply when the nontarget plants are not present or not actively growing. For example, broadleaf herbicides are usually best applied in late fall to avoid vegetable and ornamentals while controlling perennial broadleaf weeds in turfgrass. In most cases, these products will effectively control perennial weeds in late spring or early summer, too. However, numerous sensitive, nontarget plants are also present at those times of year.

Use extreme care when applying nonselective herbicides. Directed sprays are used to prevent contact with leaves, shoots or green stems/bark of desirable plants. Droplets too small to be seen will readily move through the air and damage sensitive plants. Shielded sprays, where a cone surrounds a nozzle, will help prevent the spray from contacting the foliage of a non-target plant. A wiper (wick)

application, where an herbicide solution is wiped on weed foliage only, is another way to use non-selective herbicides safely around desired plants.

Be aware that some herbicides will leach vertically through the soil profile. They may injure or even kill sensitive trees and shrubs if their roots extend under the treated soil. Shallow-rooted plants or those with surface roots are especially vulnerable. Rainfall may move these products into the root zone, leading to injury. Atrazine, simazine, metribuzin and dicamba are turfgrass herbicides with potential for vertical and lateral movement. Manor, TranXit, Revolver, Corsair and Kerb are herbicides that may move with runoff water under certain conditions. It is also possible to cause injury to a bentgrass green if traffic crosses the treated area and moves onto the green before the spray dries. Heavy rainfall shortly after application may cause off-site movement of these products, especially if the soil is already saturated.

When finished applying granular herbicides or fertilizers, sweep or blow them off hard surfaces such as parking lots, driveways, sidewalks and streets to prevent contamination of runoff water. Turf acts as a filter, but the materials left on impervious surfaces go directly into storm sewers or ditches and eventually into the water supply. Monitoring of rivers in the Atlanta area has shown a spike in turf pesticide and fertilizer levels during the busy spring-early summer season.

## Herbicide Resistance

A number of weed species that were once susceptible and easily managed by certain herbicides have developed resistance. These weeds are no longer controlled by applications of previously effective herbicides.

Herbicide resistance probably develops through the selection of naturally occurring biotypes of weeds exposed to a family of herbicides over several years. A biotype is a population of plants within the same species that has specific traits in common. Resistant biotypes may have slight biochemical differences from their susceptible counterparts that eliminate sensitivity to certain herbicides. Resistant plants survive, go to seed and create new generations of herbicide-resistant weeds.



While most cases of resistance have appeared in agronomic crops, dinitroaniline-resistant goosegrass has been documented in turfgrass. However, these plants are susceptible to other goosegrass herbicides such as Ronstar, Illoxan and MSMA + metribuzin. Experience has shown that the potential for developing resistance is greatest when an herbicide has a single site of action. Arkansas now has Illoxan and Oust resistant ryegrass. Australia has Roundup resistant ryegrass. Other southern states have documented simazine tolerance in annual bluegrass.

Regardless of the mechanism for resistance, becoming familiar with the herbicide mode of action can help turf managers design programs that prevent the introduction and spread of herbicide-resistant weeds. Management programs for herbicide resistance should emphasize an integrated approach that stresses prevention. Dependence on a single strategy or herbicide family for managing weeds will surely increase the likelihood of additional herbicide resistance problems.

**Some strategies for managing resistance include:**

1. Rotating herbicides having different modes of action.
2. Using tank mixtures of herbicides having different modes of action.
3. Avoiding sequential application (year after year) of the same herbicides or herbicides having the same mode of action.
4. Controlling weedy escapes in border areas and ditch banks.
5. Practicing good sanitation to prevent the spread of resistant weeds.
6. Integrating cultural, mechanical and chemical weed control methods.

## Herbicide Use Tips

1. Avoid use of ester formulations of 2,4-D, dichlorprop, triclopyr and other growth regulator herbicides during the hot months. These formulations are more likely to volatilize and damage non-target plants through vapor drift. To reduce drift, use a nozzle that produces coarse droplets (showerhead also known as a Chem-Lawn Gun) and avoid spraying when the wind speed is over 5 mph.
2. Avoid applying postemergence herbicides during the spring green-up or fall transition period of warm-season grasses. While the injury is usually temporary, it is preferable to spray while the grass is completely dormant or fully green and actively growing. If the weed infestation is severe, the benefits of weed control may outweigh the herbicide injury caused by treating during the transition periods. Compared to the growth regulators, Manor (metsulfuron) is a safer postemergence broadleaf herbicide to use on bermudagrass during the spring transition period.
3. Avoid applying excess amounts of dicamba, atrazine, simazine or metribuzin over the root zone of shallow rooted trees, shrubs and other ornamentals. They are mobile, soil-active herbicides that, under the right conditions (sandy soil and a heavy rainfall immediately after application), will be taken up by the roots of ornamentals.
4. Do not make a dormant application of Roundup, Reward or Finale to any turfgrass species except bermudagrass. The bermudagrass should be completely dormant. Even if there is only 10 to 20 percent bermudagrass green-up, injury will be severe. Remember that zoysiagrass never goes completely dormant in Arkansas.

<b>Examples of Turfgrass Herbicides Having the Same Mode of Action</b>			
<b>ALS Inhibitors</b>	<b>Lipid Synthesis Inhibitors</b>	<b>Mitotic Inhibitors</b>	<b>Photosynthetic Inhibitors</b>
Image Manage Manor Corsair Revolver	Illoxan Vantage Acclaim Fusilade	Balan Surflan Barricade Lesco Pre-M Pendulum XL Team Dimension	Princep Aatrex Sencor

5. Be aware that different turfgrass species and varieties differ in their herbicide tolerance. MSMA can be used safely on bermudagrass but will severely injure St. Augustine, centipede-grass and carpetgrass. In general, the *Zoysia japonica* derived zoysiagrasses (Meyer, El Toro, Crowne, Palisades, Empire, etc.) are more herbicide tolerant than the fine textured *Zoysia matrella* derived grasses (Emerald, Cavalier, Zorro, etc.).
6. Grasses growing in shade are more susceptible to herbicide injury. Use reduced herbicide rates or do not treat.
7. Areas on golf courses that drain onto sites (putting greens, tees) where cool season grasses (rough, bluegrass, ryegrass, and bentgrass) are planted should not be treated with Manor, Tranxit, Revolver, Kerb, Sencor, simazine or atrazine for winter weed control. Runoff water containing these herbicide residues may damage cool season grasses. Heavy rainfall immediately after applying simazine or atrazine to a golf course fairway may result in injury due to accumulation of excess herbicide in low areas due to movement with runoff water.
8. Do your own weed control experiments. Often, control information does not exist for many species that do not occur frequently. Simple control studies may be conducted by treating infested sites with recommended rates of labeled herbicides. It is important to include an untreated area within the experimental site for comparison.

## Soil Fumigation

Soil fumigants are volatile liquids or gases that control a wide range of soilborne pests. Soil fumigants are also highly toxic and are expensive. Their use is limited to high-value crops such as fruits, vegetables, tobacco, ornamentals and turfgrass. A cover, usually plastic film, is placed over the treated area to trap the fumigant vapors in the soil. In addition to many weeds, fumigants also control diseases, nematodes and insects. Weed seeds that have hard, water-impermeable seed coats, such as sicklepod, white clover, redstem and morningglory, are not controlled by fumigants. Factors to consider before choosing a soil fumigant include expense, soil moisture level, soil temperature and time available before planting. There are three compounds

available for soil fumigation in turf: (1) methyl bromide, (2) metham or metam-sodium and (3) dazomet (Basamid).

**Methyl bromide** is a colorless, nearly odorless liquid or gas. At 38 degrees F, the liquid turns into a gas and at 68 degrees F is 3.2 times heavier than air. These properties require that a cover be used or methyl bromide will escape. Methyl bromide is extremely toxic (acute vapor toxicity is 200 ppm) due to inhalation hazard, and it is commonly combined with a warning agent such as chloropicrin (teargas) to warn the user of escaping gas.

Before using methyl bromide, the soil should be in a condition suitable for planting including seedbed preparation by tilling. Control will be only as deep as the soil is adequately tilled. Soil should be moist for adequate soil penetration and dispersion. Saturated soil or extremely dry soil will limit fumigant movement, reducing the level of weed control. Soil temperature at 4 inches should be a minimum of 66 degrees F. Fumigation will not be effective if soil temperature is below 50 degrees F. Before or during application, the site should be covered with plastic film with the edges properly sealed to prevent gas leakage. The treated area should be covered for 24 to 48 hours. The cover should then be removed and the soil aerated 24 to 72 hours before planting.

**Metham - sodium** (methyl-dithiocarbamate) is a member of the thiocarbamate herbicide family. Metham is water-soluble and, upon contact with the moist soil, breaks down to form the highly toxic and volatile chemical methyl isothiocyanate. Metham should be applied to moist soil with a temperature of at least 60 degrees F. It is most effective when used with a cover, but it may be used with a water-and-soil seal method. With the water-and-soil seal method, the soil is cultivated and kept moist for a week before treatment. The material is applied, roto-tilled and watered in to the desired depth of control (usually 4 to 6 inches). Approximately seven days after treatment, the area should be cultivated to help release any residual gas. One to two weeks later (two to three weeks after initial application), the treated area may be planted. Disadvantages of metham use include the lowered effectiveness when used without a cover and the longer waiting period before planting. The oral LD<sub>50</sub> of metham is 820 mg/kg while the dermal LD<sub>50</sub> is 2000 mg/kg.

**Dazomet (Basamid)** has recently been introduced as a soil fumigant. Dazomet is a granular formulation and is not a restricted use pesticide. Dazomet must be applied accurately and uniformly and then incorporated into the soil. Its use and effectiveness are very similar to metham.

## Using Charcoal (Activated Carbon) to Deactivate Herbicides

Plan ahead. Have a supply of activated charcoal on hand. Timing is critical when dealing with herbicide accidents. The rate range for using activated charcoal is 100 to 400 pounds/acre (2.3 to 9.2 pounds/1,000 square feet). For herbicide spills, it is necessary to incorporate the charcoal into the contaminated soil, preferably to a depth of 6 inches. To be effective, charcoal must come in contact with the herbicide. The rule of thumb is to apply 200 pounds/acre (4.6 pound/1,000 square feet) charcoal for each pound of herbicide active ingredient per acre. In case of a severe spill, it may be necessary to remove the contaminated soil.

Applying charcoal can be a huge mess. If possible, avoid trying to apply the dry form because it is easily moved by wind. Look for a liquid charcoal product such as **52 Pickup**. Use a sprinkling can for small areas. For larger applications, a power sprayer is more convenient. Use tips with a large opening and remove the nozzle screens to avoid clogging. We use Spraying Systems 8008 or 8010 flat fans or a Boom Buster tip. If mixing dry charcoal with water, adding 0.5% nonionic surfactant will help the charcoal go into solution. Fill the tank half-full of water and start the agitation. Add the charcoal and the remainder of the water. The target dilution is 1 to 2 pounds of charcoal per gallon of water. Afterward, clean the sprayer, pump and lines thoroughly because charcoal is very abrasive.

To deactivate an herbicide that is still on the soil surface following an accidental application, apply charcoal slurry at 2 to 4 pounds/1,000 square feet. Water the slurry into the soil. Use enough water to remove the charcoal from the grass blades. Raking the charcoal into the soil will improve results. The area may be seeded 24 hours after treatment.

However, if the herbicide has been moved into the soil by rainfall or irrigation, surface application of charcoal will not be very effective. Charcoal will not leach into the soil.

## Turfgrass IPM

Herbicides are not a substitute for a conscientiously applied cultural program. Cultural practices are at least 60 to 70 percent of turfgrass weed control. The best means of preventing weed encroachment is a dense, vigorously growing turf. By choosing the right grass for the site and following proven fertilization, mowing and irrigation practices, weeds will be less competitive with the turf. Before deciding to use any weed control program, first determine why the turf is thin and weeds are invading. Correct the factors causing unhealthy turf before implementing an herbicide program. Weed prevention is avoiding the introduction of weeds into an uninfested area. One of the keys to making integrated pest management effective in controlling turfgrass weeds is not allowing weeds to become established. Some common sense steps to weed prevention include:

1. Use weed-free mulch and topdressing materials.
2. Use weed-free seed, sprigs, plugs and sod.
3. Keep border areas such as fence lines, roughs and ditch banks weed-free.
4. Wash or blow equipment between uses, especially when moving a mower or other piece of equipment from a weedy area to a weed-free area.

## Have a Plan

Too often weed control measures are a reaction to crisis rather than part of a well-planned and coordinated effort. Turfgrass professionals should spend at least as much time learning the conditions that lead to weed infestation as they do studying control strategies after weeds have become established.

A big part of having a plan is scouting and mapping the weeds. As you travel the sites you maintain, collect information that will allow you to be ready with the correct herbicides and plan of attack come treatment time. Late summer or early fall is a good time to make weed surveys. Follow

Turfgrass Growth Regulators					
Trade Name	Common Name	Site of Uptake	Seedhead Suppression	Mode of Action	Comments
Cutless	flurprimidol	roots	incomplete	inhibits gibberellic acid synthesis	Occasionally used in a tank mix with Prograss for suppression of bermudagrass encroachment into bentgrass greens. Needs rainfall or irrigation for activation.
Embark	mefluidide	foliage	yes	cell division inhibitor	Used for seedhead inhibition. Tall fescue in tall fescue and other grasses.
Primo	trinexepac-ethyl	foliage	no	inhibits gibberellic acid synthesis	Used on bermudagrass and zoysiagrass fairways to reduce clippings and improve turf density. Also used on bentgrass and bermudagrass putting greens.
Proxy	ethephon	foliage	no	promotes ethylene production which restricts growth	Primarily for cool-season grasses. Not much research data available.
Roll Out	cytokinins, gibberellic acid and indolebutyric acid	foliage	no	encourages cell division and elongation	Not tested in Arkansas. Label uses include fall color retention for bermudagrass.
Royal Slo-Gro	maleic hydrazide	foliage	yes	cell division inhibitor	Occasionally used to inhibit tall fescue seedheads in utility turf.
RyZup	gibberellic acid	foliage	no	encourages cell division and elongation	Not tested in Arkansas. Label uses include fall color retention for bermudagrass.
Trimmit, TGR	paclobutrazol	roots	no	inhibits gibberellic acid synthesis	Use to suppress <i>Poa annua</i> growth in bentgrass greens. Needs rainfall or irrigation for activation.

the fall survey with a spring assessment to observe spring germinating weeds. Put your survey data on paper.

PGRs are separated into two groups – Type I and Type II – based on how they inhibit growth. Type I inhibitors are primarily absorbed through foliage and inhibit cell division and differentiation in meristematic regions. They are inhibitors of vegetative growth and interfere with seedhead development. Their growth inhibition is rapid, occurring within 4 to 10 days, and lasts 3 to 4 weeks, depending on application rate. Embark (mefluidide) is an example of a Type I inhibitor that inhibits cell division in growth and development.

Type II inhibitors are generally root absorbed and suppress growth through interference with gibberellic acid synthesis, a hormone responsible for cell elongation. Type II PGRs are slower to produce growth suppression but their duration is usually from 4 to 7 weeks, depending on application rate. Type II PGRs have little effect on seedhead development and result in miniature plants. Trimmit, Scotts TGR (paclobutrazol) and Cutless (flurprimidol) are root absorbed Type II PGRS. Primo (trinexepac-ethyl) is a foliar absorbed Type II PGR that is systemically translocated to the site of activity.

Proxy 2L (ethephon) is a PGR with best activity on cool season grasses. It promotes ethylene production in plants, which is a regulatory hormone that restricts plant growth.

Root-absorbed PGRs are activated by irrigation or rainfall after application and are less likely to cause leaf burn due to overlaps in application. Foliar-absorbed materials, such as Primo and Embark, require uniform and complete coverage for uniform response and must be leaf absorbed before irrigation or rainfall occurs. Usually low application volumes (0.5 to 1 gallon per 1,000 square feet) are used for foliar-absorbed materials to minimize runoff from the leaf surface, while high volume applications (1 to 5 gallons per 1,000 square feet) are used for root-absorbed materials.

An available plant growth promoter is RyzUp from Abbott Laboratories. RyzUp is gibberellic acid, which encourages cell division and elongation. RyzUp helps initiate or maintain growth and prevent color changes during periods of cold stress and light frosts on bermudagrass such as Tifdwarf and Tifgreen. Bermudagrass greens may experience an early light frost before the overseeding has become established. RyZup helps the turfgrass recover from this discoloration. PGRIV from MicroFlo and Roll Out from Griffin are combinations of gibberellic acid and indolebutyric acid that is foliar absorbed. Research suggests that this combination promotes root growth and vigor of certain plants growing under stressful conditions.

# Turfgrass Disease Management

## Plant Diseases – An Introduction

A plant disease can be defined as an abnormal alteration in the structure and/or physiological function of a plant. This alteration often leads to the development of symptoms, which is the visible expression of a disease. Some diseases produce specific symptoms that are used in diagnosing the disease. The causes of plant diseases may be broadly divided into two basic groups: abiotic (nonliving agent) or biotic (living agent). Abiotic diseases are caused by an unfavorable growing environment. Examples of environmental stress include water stress, temperature extremes, nutrient imbalances and plant injury (chemical or mechanical). Biotic plant diseases are most commonly caused by living microscopic organisms called pathogens. These diseases are often referred to as parasitic diseases. A parasitic disease is the end result of three very important factors that make up the “**disease triangle**” (Figure 4.1). This triangle consists of a **susceptible host plant**, a **favorable environment** and a **pathogen** (causal agent) capable of infecting the host plant. There is a very close relationship between these three factors. If one of these factors is incompatible with the other two at a specific time, there will be no disease development. The most common plant disease pathogens consist of fungi, bacteria, viruses and nematodes. Biotic diseases usually develop over an extended period of time, whereas abiotic diseases usually develop over a short time period.

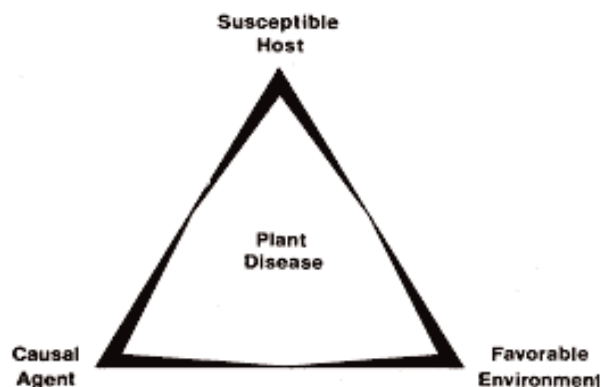

FIGURE 4.1. Disease triangle.

**Fungi** cause the majority of severe diseases on plants. The thread-like body (hyphae) of a fungus usually reproduces by forming microscopic seed-like structures called spores that are commonly spread from one plant to another by wind, splashing water, equipment, animals and infected plant parts. The fungi may enter the plant by natural openings (stomata, lenticels and nectarines), wounds and direct penetration. Fungi cannot manufacture their own food. They rely on a host plant for nourishment. They live on dead or living plant or animal matter. Spores land on a leaf surface, germinate and penetrate the leaf tissue. This is called the infection process, after which disease symptoms appear. Use of protectant fungicides interrupts this process and prevents disease from developing. Understanding the preventive nature of this process helps an applicator understand the importance of proper spray intervals and adequate coverage of foliage. Not all fungi are detrimental to plants. Some fungi are beneficial because they break down organic matter and are extremely important in the food-making process and the production of some antibiotics. Significant plant diseases caused by fungi include late blight of potato, downy mildew on grapes, powdery mildew on many field-grown ornamentals, cereal rusts and smuts, Chestnut blight, daylily rust, Dutch elm disease, brown patch of turf, brown spot of rice and soybean rust.

**Bacteria** are single-celled microorganisms that reproduce by dividing themselves. Most plant pathogenic bacteria are rod-shaped microorganisms that divide rapidly. Under optimum conditions, bacteria may divide every 20 to 50 minutes, one bacterial cell becoming two, two becoming four, four becoming eight and so on. Bacteria enter plants through wounds created on the plant or through natural openings, such as the stomata on the leaf, nectarines of the flower and lenticels on the stems. Bacteria are spread by splashing water, wind, equipment, animals and soil. Some insects are important vectors of bacterial diseases. Most bacterial diseases are related to moist environments where plants are grown. The bacteria commonly infect plants by being splashed onto wet plant foliage from the soil.

**Viruses** are much smaller than bacteria and can exist and multiply only inside living cells. Viruses enter the plant only by wounds made

mechanically or by vectors or occasionally by infected pollen grains. These agents do not divide and do not produce any kind of reproductive structure like spores of a fungus. They multiply by inducing the cells of the living host plant to form more virus particles. They are spread mainly by contact between plants, sucking insects (leafhoppers, whiteflies and aphids), propagation of infected plants and contaminated equipment. Mosaic (a mixture of dark and light green areas), flecking and ringspotting are foliar symptoms typical of viruses. Viruses can also cause stunting and other growth disorders. The disease symptoms of some virus infections often resemble other plant problems, such as herbicide injury and nutritional imbalances. Viruses may remain from season to season in perennial weeds, insects, nematodes and seeds. Once a plant is infected with a virus, no practical treatment for complete removal of the pathogen exists. Plant removal is often recommended to prevent spread of the virus to healthy plants. Infected plants may serve as a reservoir for additional infections when there is an insect or other vector present that can transmit viruses. Chemical control for virus diseases is not effective. Diseases caused by viruses include rose mosaic, tobacco mosaic, tomato spotted wilt, impatiens necrotic spot, barley yellow dwarf of wheat and plum pox of stone fruits.

**Mycoplasmas** are ultramicroscopic organisms that lack a true cell wall but are bounded by a “unit” membrane. They grow to various shapes and sizes. These organisms reproduce by budding and binary fission. They do not produce spores like the fungi. Spiroplasmas and Phytoplasmas are related organisms and cause diseases including corn stunt, aster yellows and elm yellows. These organisms may be found in the food conducting tissues of the plant.

**Nematodes** constitute a serious problem with many plants. Nematodes are microscopic, round worms approximately 1/50-inch long. If they have a satisfactory food source, they reproduce rapidly. A single female nematode may lay up to 500 eggs at a time. Once the eggs hatch, the immature nematode will undergo several morphological changes as it matures into an adult. Nematodes can be found in all types of soil but tend to be most numerous in sandy or light-textured soils. Nematodes are usually spread by soil movement or irrigation water. Many types of plant parasitic nematodes exist, but the most common one is the root-knot nematode. This nematode may attack many species of economically

important plants. Most of the damage inflicted by nematodes is a result of direct feeding on the roots. The nematode inserts a sophisticated feeding tube (stylet) into the cells of the root. Although the majority of plant parasitic nematodes feed on the roots of plants, some feed on the leaves. Plants with knotted or galled root systems cannot absorb enough water and nutrients to adequately supply the plant. The tops of plants may appear wilted or inadequately fertilized. Once the soil becomes infested with nematodes, it is difficult to eradicate them completely by conventional means. Damage to the plant may not become apparent until the nematode population increases beyond an economic threshold for the host plant. Chemical treatment is often used to reduce the population so that a reasonable crop can be grown. Important nematode problems include root-knot on many ornamentals and vegetables, lesion nematode, cyst nematode on soybean, reniform nematode on cotton, foliar nematode on ornamental foliage plants and pinewood nematode.

**Parasitic higher plants** such as dodder, mistletoe and witchweed obtain all or part of their nutrition from a host plant. The dodder produces a yellow, small diameter vine that attacks plants intertwining around the host plant. With the aid of a specialized absorbing organ (haustoria), it drains nutrients and water from its host. The mistletoes can be found on a number of woody plants. These parasitic plants have chlorophyll and produce sticky seed dispersed by birds that eat them. Control is difficult to achieve. Witchweed, another parasite, is not common in North America. It is a parasite on corn, rice, sugarcane and a few small grain crops. Heavily infected plants die as a result of the roots being parasitized by witchweed.

Abiotic plant disorders constitute a vast majority of problems with ornamentals in the landscape. Among the most common problems are moisture and temperature stress, improper planting and maintenance, improper site, improper fertilization and pesticide application and string trimmer injury. When plants are stressed, they are more vulnerable to the effects of attack by disease-causing pathogens and insects. Although some pathogens will attack vigorously growing and healthy plants, many attack and infect only plants that are stressed. A weakened tree or shrub is much more susceptible to cankers, wood decay, root rot and certain wilt diseases than a vigorously growing ornamental.

Accurate disease identification is the first important step in planning an effective and efficient disease control program. An understanding of the pathogens' life cycle and mode of action is crucial in developing control strategies. Literally thousands of specific diseases exist. As growers, we may encounter only a few during a particular season, but we must be able to distinguish significant and potentially serious diseases from those of lesser significance.

## Turfgrass Disease Descriptions

Lawns constitute a significant place in home landscapes. For a landscape to be healthy and attractive, the lawn must be healthy. Turfgrass diseases can seriously damage the appearance of a home lawn, athletic field or golf course. With few exceptions, fungi are more damaging to turfgrass plants during wet weather or when moisture from rain, irrigation or dew remains on the leaves for a long time than during dry weather. In Arkansas, the fungi are responsible for most of the infectious (biotic) diseases of turf. The bacteria and virus diseases are considered minor problems in turfgrasses. The fungi that cause turfgrass diseases have specific temperature ranges and are active during different times of the year. Some diseases are more prevalent than others, depending on the season.

**Brown patch** (*Rhizoctonia* spp.) is caused by a fungus that affects grasses when night temperatures are cool in the fall and spring. *Rhizoctonia* affects both warm and cool season turfgrasses in Arkansas. Disease symptoms depend on whether it is a cool or warm season grass, cultural practices and environmental conditions. Brown patch develops most rapidly during periods of warm temperatures (75 to 85 degrees F) and moist or wet conditions. On warm season grasses, the disease can be a problem during the fall, winter and spring when grasses are entering or emerging from dormancy. Infected turfgrass usually exhibits irregular or circular patches of blighted grass ranging from several inches to many feet in diameter (**Figure 4.2**). The bases of infected leaves become rotted and can easily be pulled from the bottom of the grass plant. The fungus primarily attacks the shoots rather than the roots. Roots of affected grass generally will not be discolored, and green grass will occasionally be present in the middle of diseased patches, giving a "smoke ring" appearance.



**FIGURE 4.2.** Brown patch symptoms on zoysia.

To reduce the severity of brown patch, irrigate only when needed and do so early in the morning. Although several fungicides are labeled for control of brown patch, effectiveness is much greater when applied before the disease becomes well established. Brown patch severity is directly related to the fertility status of the turfgrass. High nitrogen tends to increase disease severity.

**SAD** (St. Augustine Decline) is the most significant virus disease of turfgrass in Arkansas. SAD is caused by panicum mosaic virus. This disease occurs only on St. Augustine and centipedegrass. Leaves appear mottled. Do not confuse this with iron chlorosis, which causes a striped appearance. In iron chlorosis, the veins remain green and the chlorotic areas occur between the veins. If the virus is present, however, a mottled or speckled condition occurs in the leaf tissue. Another distinguishing factor is that iron chlorosis appears first in the new or young leaves, whereas SAD causes yellowing in both old and young leaves (**Figure 4.3**). SAD is spread by lawn mowers and cannot be controlled with chemicals. The best control of this disease is to plant one of the commercially available, resistant St. Augustinegrass varieties.



**FIGURE 4.3.** SAD on St. Augustinegrass.



**Fairy ring** is a condition caused by fungal development in the soil. Several fungi can cause fairy ring. Most are growing in association with organic material buried in the soil such as decomposing stumps, branches or building materials. All turfgrasses can be affected by fairy ring. The fungi can be located at varying depths in the soil, making it virtually impossible to remove by digging infested soil out of the area. Fungi that typically produce mushrooms invade organic matter in the soil (**Figure 4.4**). It then produces mushrooms on the edge of this organic matter, and a ring effect is often noted. The disease becomes noticeable during spring and summer months when a ring of dark green grass or brown circular bands appear. The dark green grass is a result of nitrogen released after fungi decompose organic matter in the soil. The brown ring of dead or dying grass appears as a result of a hydrophobic (water repelling) effect from the spreading fungi. Mushrooms can be removed by mowing, and proper irrigation and fertilization will suppress or mask the green or brown rings associated with this disease.

Managing fairy ring involves forcing water into the hydrophobic or dry areas and using fungicides specifically labeled for this disease. Wetting agents added to the water may help penetration. This disease is considered more of a cosmetic problem in the home lawn, whereas it may be significant in a golf course situation. Fungicides are available that suppress disease development; however, multiple applications will be necessary to maintain suppression of this disease.



**FIGURE 4.4.** Mushrooms of fairy ring.

**Take-all patch** (*Gaeumannomyces graminis* var. *graminis*) is a serious fungal problem in St. Augustinegrass and bermudagrass. This disease is most active during fall, winter and spring when soil is moist and temperatures are moderate.

Take-all patch can destroy large areas of grass if not controlled. The first symptom of take-all patch is yellowing of leaves, usually in large circular or irregular shaped patches (**Figure 4.5**). The grass gradually thins within the patch. The roots of infected plants are frequently rotted, but the leaves cannot be easily pulled from the plant, as is the case with brown patch. Because the fungus that causes take-all patch survives on plant debris, use practices that prevent thatch buildup. Take-all patch tends to be more severe on soils with a high pH. Although there are fungicides labeled for control of this disease; these chemicals should be applied on a preventive basis, generally in the fall. On an already established take-all patch, fungicides may be ineffective.



**FIGURE 4.5.** Take-all patch.

**Gray leaf spot** (*Pyricularia grisea*) is a disease of St. Augustinegrass in Arkansas. This disease can be a problem in the spring and early summer, especially in shaded areas. Symptoms include tan lesions with purple or brown borders on the leaf blades (**Figure 4.6**). Eliminating the use of soluble nitrogen fertilizers during summer months on shaded lawns can reduce the severity of the disease. Water early in the morning and remove grass clippings from infected lawns to slow the spread of gray leaf spot. Several fungicides are labeled for control of this disease.



**FIGURE 4.6.** Gray leaf spot on St. Augustinegrass.

**Dollar spot** (*Sclerotinia homeocarpa*) is a fungal disease that attacks most turfgrasses grown in the South. Hybrid bermudagrass, zoysiagrass and bentgrass are particularly sensitive to this disease. Generally occurring in the spring through the fall, it prefers low soil moisture. The disease receives its name from the development of small, circular, brown to straw-colored spots, roughly the size of a silver dollar, sometimes larger on coarse-textured grasses. Not to be confused with brown patch, grass blades affected by dollar spot exhibit light tan lesions with reddish-brown bands (**Figure 4.7**). Dollar spot is often associated with poor turf maintenance. Dry soils, thatch buildup and inadequate amounts of nitrogen and potassium favor this fungus. Control dollar spot by removing thatch, fertilizing properly and avoiding shallow, frequent watering. Several fungicides are recommended to prevent dollar spot.



**FIGURE 4.7.** Dollar spot on bermudagrass.

**Spring dead spot** (SDS) is a very destructive disease in bermudagrass lawns. Two fungi (*Leptosphaeria korrae* and *Ophiosphaerella herpotricha*) are associated with the disease in North America. Bermudagrass is the most significant host to this disease. The causal organisms grow most actively during the fall and spring when temperatures are cool and soils are moist. Bermudagrass varieties that have poor cold hardiness tend to have more severe SDS. SDS-infected lawns exhibit small, circular, dead areas from less than one to several feet across in the spring (**Figure 4.8**). This disease becomes noticeable during greenup in the spring. Other symptoms include dark and rotted roots and a slow recovery of bermudagrass into the affected areas, usually about midsummer. SDS does not affect newly planted lawns but becomes a problem on lawns three to four

years old. It may be connected to an accumulation of thatch. In some locations, SDS has been controlled with repeated applications of systemic fungicides in the early fall.



**FIGURE 4.8.** Spring dead spot.

**Rust** (*Puccinia* sp.) can be found on a number of turfgrass species, but is most frequently a problem on zoysiagrass, fescue and bermudagrass. Grass that is under stress during warm, humid conditions is most susceptible to the disease. Rust is identified by orange to reddish-brown flecks on grass blades that develop into pustules and eventually turn brown to black (**Figure 4.9**). Ryegrass can be very susceptible to rust in the spring, especially when nitrogen levels are low.



**FIGURE 4.9.** Zoysia leaf rust.

Severely infected turf looks reddish brown, yellowish or orange. The turfgrass often thins and becomes chlorotic. Cool to moderately warm, moist weather favors rust development. Condensed moisture, even dew, for 10 to 12 hours is sufficient for rust spores to infect plants. Cultural practices such as proper fertilization, avoiding moisture stress and

selecting resistant varieties can help prevent rust. Removal of grass clippings from affected areas is helpful. Spores on the mowed leaves die out rapidly. The rust over-seasons in infected grasses. The over-wintering rust produces short, black streaks on the leaves. If cultural practices are inadequate, there are a number of fungicides recommended for rust control.

**Pythium blight** (*Pythium* sp.) is caused by several species of *Pythium* fungi. The infection process, symptom development, spread of the pathogen and destruction of turf is often very rapid. This disease is most prevalent on highly maintained turf such as golf course greens. This disease is often associated with waterlogged soils and a moist thatch layer, along with high relative humidity and daytime temperatures in the 80s and 90s with warm nights (above 70 degrees F). These conditions are ideal for warm weather pythium blight. There are cool weather pythiums also. The disease often appears as elongated streaks, following water drainage or mowing patterns. Large areas of turf can be destroyed within 24 to 48 hours after disease onset. Excessive nitrogen favors this disease. Wet turfgrass and poor soil drainage are the two most important criteria for disease development. For control, both surface and subsurface drainage needs to be improved. Avoid overwatering, thick thatch, excessive nitrogen fertilization and compacted soil profiles. Systemic fungicides when applied as part of a preventative program before the onset of hot, humid conditions is recommended for high value turfgrass.

**Nematodes** are probably the most abundant form of animal life in the soil. Most species that occur in soil feed on fungi, bacteria or small invertebrate animals; but many are parasites of higher plants, including turfgrass. Nematodes have distinctive life cycles very similar to those of insects. Females lay eggs, which hatch into larvae. The larvae mature through a series of four molts to become adults. Nematodes typically survive adverse conditions in the egg or larval stages and feed most actively when the turfgrass is also actively growing. Nematodes are mobile within the soil, but long distance spread usually requires their movement in surface water runoff, in soil on equipment or in sod.

All turfgrasses are susceptible to nematode damage. In Arkansas, nematodes can cause

significant damage and need to be controlled on bentgrass golf greens and sod farms. Plant parasitic nematodes feed on turfgrass roots and on other organs by puncturing the plant cells with a hollow, needle-like structure called a stylet (**Figure 4.10**). Nematodes cause direct impairment of root functions, and nematode-weakened plants are susceptible to infection by various pathogenic fungi and bacteria. The aboveground symptoms of a nematode infestation include chlorosis (yellowing) of the leaves, slow growth, gradual thinning, poor response to adequate fertilization and irrigation, rapid wilting during dry weather and weed invasion.



C.C. Russell

**FIGURE 4.10.** Schematic drawing of a plant parasitic nematode.

Nematodes are most damaging in light, sandy soils which are low in nutrients and water-holding capacity. Increased fertilization and irrigation practices can often overcome the effects of some types of nematodes. Highly compacted and heavy-textured soils are less favorable to nematodes because they restrict nematode movement and prevent good turfgrass growth. Nematodes are usually most active and most numerous on warm-season grasses during the summer and autumn, on cool season grasses in mid to late spring, and again in autumn. These times correspond with and follow

active growth of turfgrass roots. However, the result of nematode feeding generally becomes most apparent when conditions become unfavorable for the turfgrass. For high maintenance turfgrass, such as golf greens and sod farms, chemical control of nematodes may be necessary. Because of their distribution in the soil profile and their position on or in the roots, complete chemical control is impossible, but reductions of large populations to manageable levels can be achieved with chemical nematicides. The only way to determine if nematodes are involved is to have soil samples assayed for nematodes. They seldom, if ever, are controlled in home or recreational turfgrass.

**Slime molds** are harmless but unsightly fungi that seem to suddenly appear over the grass surface during warm weather, following heavy rains or watering. These fungi may be black, bluish-gray, cream to yellow or white in color and grow in round to irregular patches (**Figure 4.11**). These organisms are not parasitic on turf but feed on decaying organic matter, other fungi and bacteria in the thatch layer and soil. Slime molds usually disappear when dry conditions are present. Raking, brushing or hosing down the area with water is helpful in speeding their disappearance.



**FIGURE 4.11.** Slime mold on zoysiagrass leaves.

## Turfgrass Disease Summary

Diseases, whether abiotic or biotic, can be destructive to all plants. It is very helpful to become familiar with the way healthy plants look in the landscape. Proper placement and maintenance are of the utmost importance in overall plant health. We have discussed the interactions of the “disease triangle” and its role in disease development. Infectious disease development is an ever-changing and dynamic process in which a series of events occurs in succession that leads to the development and perpetuation of the disease and a pathogen.

In order to diagnose a plant disease, it is important to determine if the disease is caused by a pathogen (fungus, bacteria, virus, etc.) or if the problem is a result of an unfavorable growing environment. Accurate identification is the most important step in designing an effective disease control program. Details of the symptom expression on individual plants are very important in the diagnosis of plant diseases. Each causal agent, biotic or abiotic, will produce some specific symptoms. These symptoms may vary, depending on the plant, growth stage, exposure time, etc. The ability to anticipate and react appropriately to common problems and implement preventive solutions can be quite valuable in maintaining a healthy lawn grass and landscape planting.

The aim of this information is to help with the diagnosis and understanding of disease mechanisms of ornamentals and turfgrasses. It describes many common diseases that have distinctive symptoms. This information offers comments on controlling these various diseases.

For further information and assistance with plant disease identification and control, consult your local Extension office.

# Turfgrass Insect Pest Management

## Introduction

Insect and mite damage to turf is often mistaken for a disease, drought or fertility problem. The symptoms are often similar: chlorosis, wilting, dieback, stunting or distortions of growth. As a result, it is not uncommon for pests to inflict extensive damage before their presence is realized. Early detection of such symptoms may prevent the rapid buildup of pest populations that can occur when conditions are right.

Good control depends on correct identification of the pest, some knowledge of its behavior and biology as well as environmental factors, such as temperature, moisture, soil type and location, which affect population buildup. This information also helps determine the appropriate insecticide to use and the rate and method of application that will control a pest. Some pests thrive in warm, dry conditions; others prefer wet, moist conditions. Some locations in turf may be more susceptible to infestation than others. Often, pests are first found in isolated spots rather than distributed evenly throughout the turf. Also, conditions of shade or sun, slope and soil type can influence pest establishment.

Serious insect and related pest infestations are sporadic and generally unpredictable. Therefore, the application of pesticides to turf should not be preventive in nature. It is wiser economically and ecologically to treat damaging infestations only as they occur. In this way, the development of resistance to pesticides will be delayed, the buildup of harmful residues will be unlikely, populations of beneficial organisms can be maintained and costs will be reduced.

## Detection and Survey Techniques

Selecting the proper pesticide depends on proper diagnosis of the pest problem. Insects must often be disturbed or trapped in order to properly identify them. Some of the sampling procedures are described below.

**Flotation** – Flotation is a method using water to detect the presence of insects such as the chinch bug. Select a large can, such as a two-pound coffee can or one with a diameter of at least 6 inches, from which both ends are removed. Push the can into the turf, through the thatch into the soil surface, in an area suspected of being infested with chinch bugs. Then fill the cylinder with water. If the water recedes, more should be added. Chinch bug adults and nymphs present in the thatch soon float to the surface. Within 5 to 10 minutes, the entire population present within the cylinder will have surfaced.

**Use of Irritants** – Irritation is another effective method of detecting certain insects. It involves sprinkling a gallon of water containing an irritant over a square yard of turf to bring pests to the surface. This method is primarily effective in detecting caterpillar-type insects such as sod webworms and cutworms, although it has been used successfully for billbug adults and mole crickets. One readily available irritant is household detergent. Add one-quarter cup of dry or one ounce of liquid detergent to one gallon of water in a sprinkling can and apply the solution to one square yard of turfgrass where infestation is suspected. One tablespoon of a commercial garden insecticide containing 1 to 2 percent pyrethrin in one gallon of water is also very effective. Larvae usually come to the surface within 10 minutes. If the thatch is dry, irrigation before the test is advisable. This method does not bring soil-inhabiting insects such as grubs or billbug larvae to the surface.

**Pitfall Traps** – This trap can be made with three plastic cups. The upper interior cup is modified to act as a funnel to direct captured specimens into the collection cup below. A hole the size of the cup is made in the turfgrass, and the cup is placed in the hole so the lip is at the thatch-soil level. Alcohol or water is placed in the collection cup. Insects crawling through the turf fall into the cup, through the funnel and into the collection cup containing alcohol/water. Trap contents should be emptied daily. These traps can be used to monitor and detect the presence of chinch bugs, adult billbugs and many other arthropods.

**Soil Sampling** – The techniques required to sample the soil underlying turfgrass areas are not only the most arduous but also the most disruptive of the turf's appearance, especially when soil samples must be as large as one square foot because the population is likely to be scattered. Because turf-damaging insects remain strictly in the soil, disrupting the soil is necessary to obtain accurate counts. The least disruptive method of examining 1 square foot of sod is to cut three sides and turn back the cut area as if it were a flap. This procedure allows many of the plants to keep their root systems intact.

The motorized sod cutter provides another convenient means of checking for soil pests. For example, setting a cutter for a depth of 2 inches would allow for easy inspection for grubs during the most active feeding periods in the spring and fall.

A standard golf cup cutter that takes a sample of sod and soil 4.25 inches in diameter is a very useful tool for sampling smaller, soil-inhabiting pests. Once removed, samples can be examined on the spot with soil and turf being placed back in the hole made by the sampler. To convert the number of insects found per sample to the number per square foot, multiply by a factor of 10.15.

In the case of white grubs, it is extremely important that the soil be at least moist when shallow samples are made. Grubs will tend to move down during dry periods. In suspected grub-damaged areas where it is extremely dry, do not give up on grub presence until you have sampled the soil 6 to 10 inches below the turf.

**Visual Observation** – Observation and a keen sense of awareness are of paramount importance in detecting developing or potential insect problems. Examples of situations and conditions to watch for include:

1. The potential for turf-damaging populations of grubs can be estimated by observing the density of adults on some of their favorite host plants, e.g., May or June beetles frequently feed on the young, tender leaves of oaks, persimmon, hickory, walnut and elm.
2. Be watchful for billbug adults on sidewalks and driveways adjacent to turf. This can signal the potential for larval infestation in adjacent turf.
3. Small moths flying erratically over turf at dusk can indicate possible sod webworm problems.
4. Sod torn up in small or large areas may be from skunks, raccoons or armadillos searching for grubs.
5. Birds frequenting turf often signal infestations of sod webworms, cutworms or grubs. Also, numerous circular holes in turf are often probes made by birds searching for cutworms or webworms.
6. Ball-mark type injury on golf greens that have holes in the center and the grass eaten off below the cutting level of green mowers may indicate cutworm or armyworm activity.
7. A general droughty looking turf, where water should not be a problem, may signal a chinch bug infestation.

## Management Practices

As noted above, diseases, unfavorable soil conditions or poor cultural practices may cause similar symptoms. These possibilities should be investigated before pest control measures are taken. In fact, the first line of defense against turfgrass pests is a program of good cultural practices. Poorly kept turf shows pest injury sooner and recovers more slowly than vigorous, well-kept turf.

Good fertilization, watering and aeration programs cannot be overemphasized. The vigor of a turfgrass directly influences its ability to withstand insect population pressures, even though maintenance may be entirely independent of any consideration of turfgrass insects. Since injury by turfgrass insects is caused mainly by their feeding, a vigorous, steadily growing stand can be one of the strongest deterrents to permanent turf damage because of the plant's active regenerative capacity.

Thatch, allowed to accumulate and develop a thick layer of organic matter on the soil surface, can greatly influence the amount of damage an insect pest causes. Initially, it provides a haven for insects. Also, thatch buildup results in poor water penetration and aeration, which weakens the grass and may make it more susceptible to insect damage. While damage occurs where thatch is not a factor, many cases of severe damage are associated with it.

Thatch, when it is thick or tight, greatly limits the effectiveness of insecticides in the control of soil-inhabiting turfgrass insects. Insecticides applied to the sod surface may be absorbed by the thatch, preventing their movement even to the surface soil. When long, residual, chlorinated cyclodiene insecticides, such as chlordane and dieldrin, were used for grub control, these materials eventually moved through and penetrated the soil through various actions of weather.

To be effective, organophosphate (OP) and carbamate insecticides must move through the thatch into the surface soil rapidly because of their short residual activity. Some are degraded completely in less than a month. The most effective medium for percolation through thatch and into soil is water, either natural rainfall or irrigation. As a general rule of thumb, there is often less thatch tie-up with OPs that are more water soluble than with the less water-soluble materials.

## **Insecticides**

Specific insecticide recommendations have purposely been omitted. Label changes, regulatory actions, new product development and budgetary restraints make it virtually impossible to ensure that a publication of this nature is reprinted on a timely enough basis to be current. There are fact sheets and other current control information publications for turfgrass pests available through the county offices of the Cooperative Extension Service.

It is worthy mentioning that there is the possibility of insecticidal resistance developing in the turfgrass pest complex. In this regard, we suggest using a preventative strategy of rotating products used for control. Continued use of one insecticide or one class of insecticide places a definite selection pressure on certain genes for resistance. Alternating between insecticides of different structure and class is suggested in the hope that it will help prevent or retard the development of resistance. It is extremely helpful to water the area to be treated (at times both before and after treatment), but rely on label indications for this possibility (e.g., when it is extremely dry, heavy watering or rainfall will be needed to bring white grubs up closer to the root zone so chemicals will have a chance to work).

## **Insect Identification**

The following pages provide descriptions (pests and damage), as well as pictures of turf pests, and pests' life cycles and occurrence information. The most prevalent and recurring turf pest (encountered on turf farms and golf courses) is the white grub. The other pests described in the following pages may be found in turf in isolated areas of Arkansas each year; however, the more common situation is to find only one or two of these pests during any one growing season with the remainder only occurring sporadically or not at your location.



FIGURE 5.1. White grub (larva),

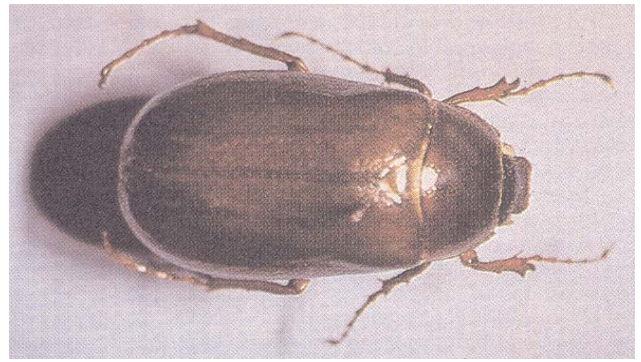

FIGURE 5.2. May/June beetle (*Phyllophaga* sp.).

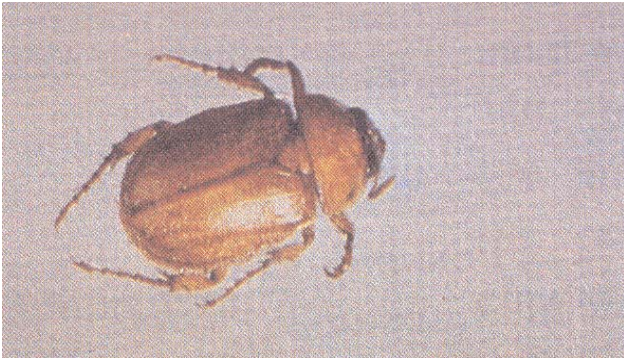

FIGURE 5.3. Annual white grub adult (*Cyclocephala* sp.).



FIGURE 5.4. White grub damage.

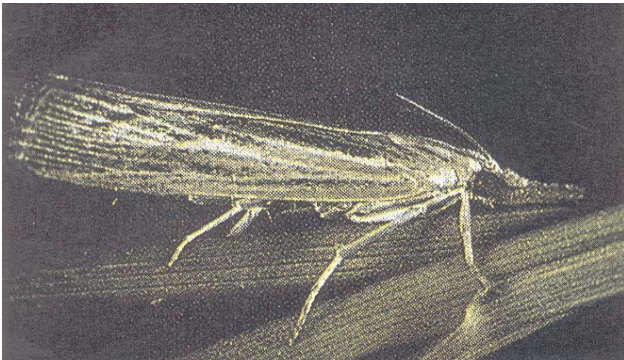

FIGURE 5.5. Sod webworm (adult moth).

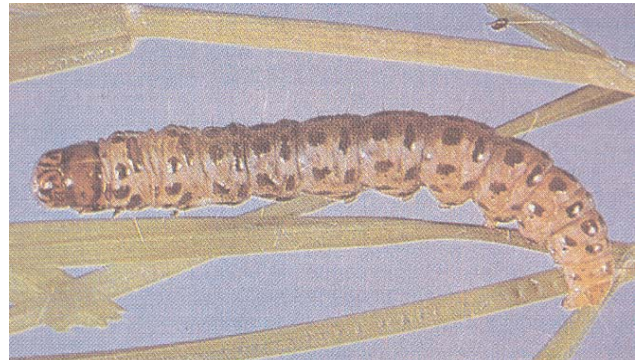

FIGURE 5.6. Sod webworm (larva).



FIGURE 5.7. Sod webworm damage.



FIGURE 5.8. Variegated cutworm (adult moth).



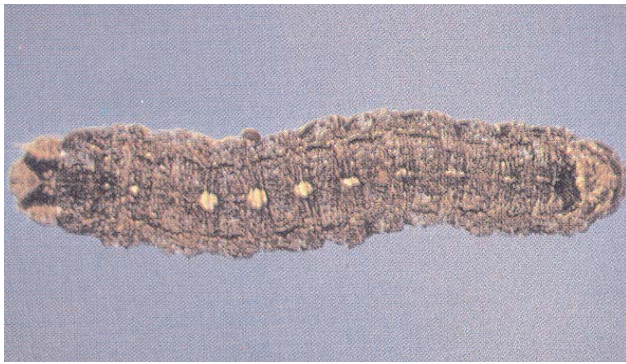

FIGURE 5.9. Variegated cutworm (larva).



FIGURE 5.10. Black cutworm (larva).

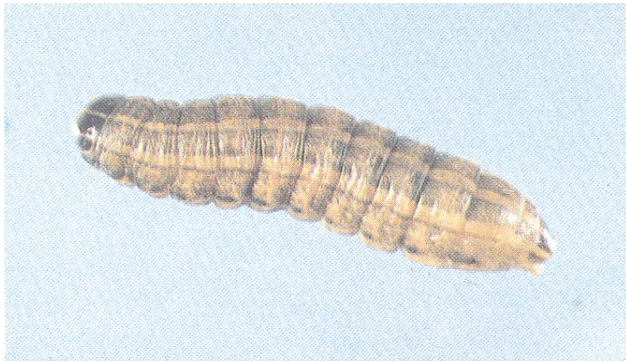

FIGURE 5.11. Bronzed cutworm (larva).



FIGURE 5.12. Granulate cutworm (larvae).



FIGURE 5.13. Armyworm adult (moth).

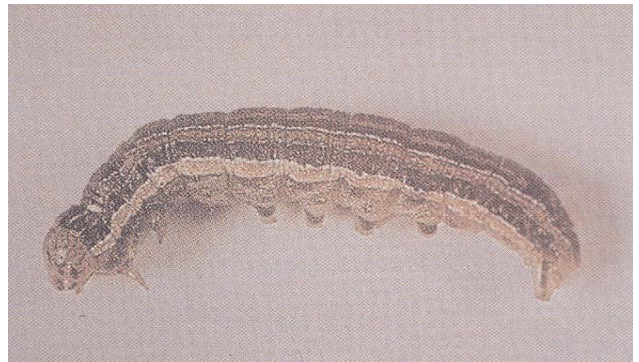

FIGURE 5.14. Armyworm (larva).

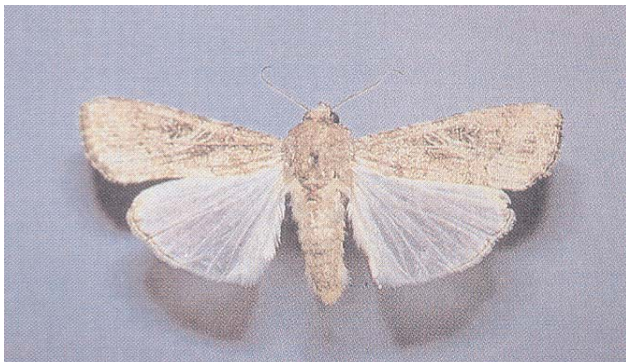
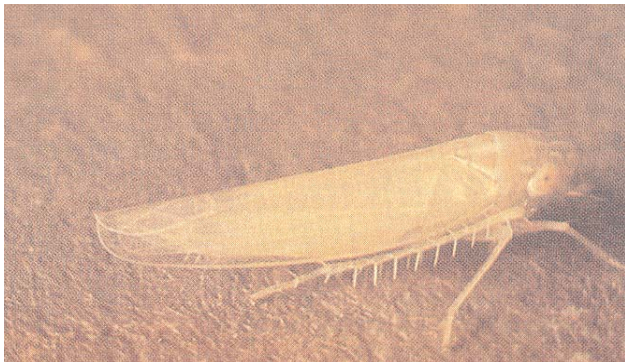

FIGURE 5.15. Fall armyworm (adult moth).



FIGURE 5.16. Fall armyworm (larva).



**FIGURE 5.17. Leafhopper (side view).**



**FIGURE 5.18. Leafhopper (top view).**

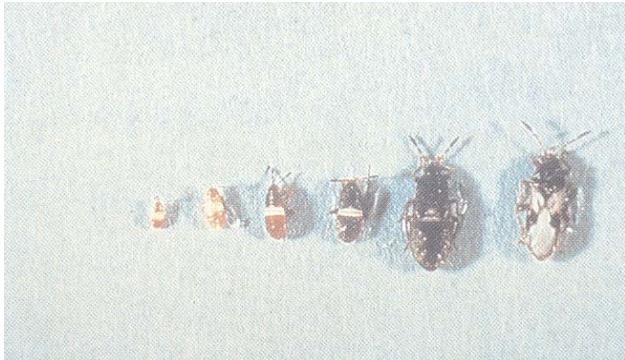

**FIGURE 5.19. Chinch bug (growth stages).**



**FIGURE 5.20. Chinch bug damage (St. Augustine grass).**



**FIGURE 5.21. Clover mite.**



**FIGURE 5.22. Bermudagrass mites (closeup).**



**FIGURE 5.23. Bermudagrass mites.**



**FIGURE 5.24. Spider mite.**



FIGURE 5.25. Damage from Banks grass mites.

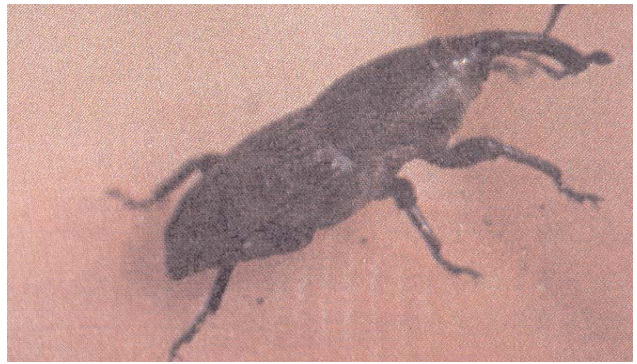

FIGURE 5.26. Billbug (adult).

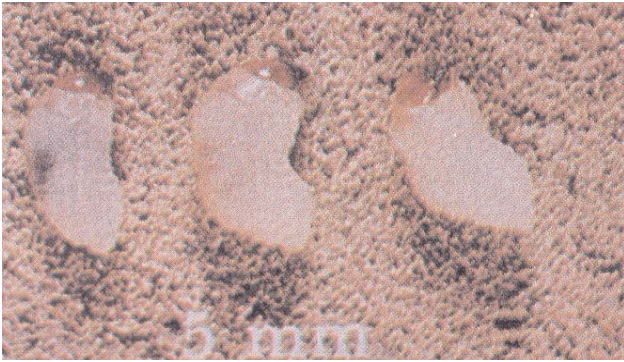

FIGURE 5.27. Billbug (larvae).

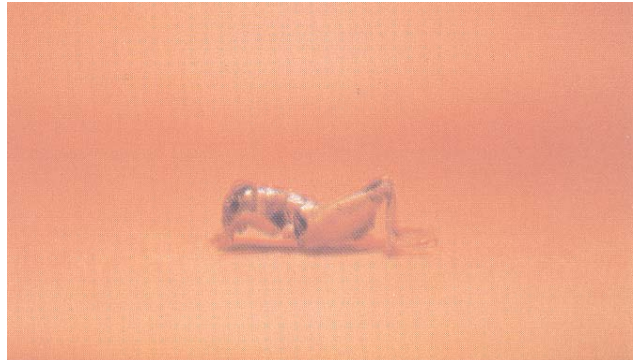

FIGURE 5.28. Shorttailed cricket.



FIGURE 5.29. Frit fly (adult).

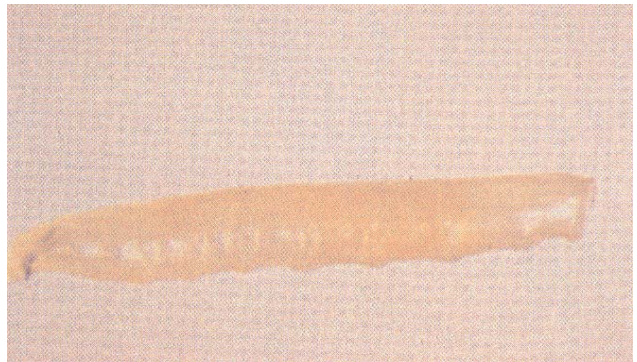

FIGURE 5.30. Frit fly (larva).

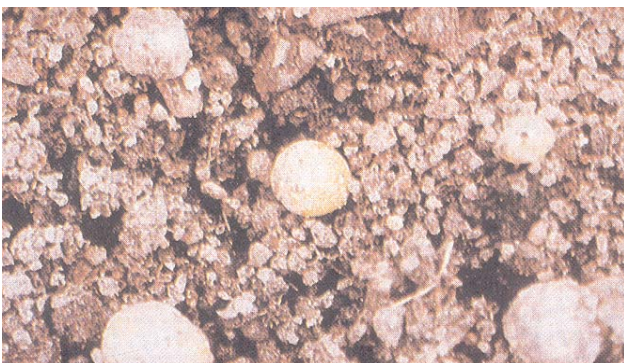

Figure 5.31. Ground pearls.



Fig 5.32. Red imported fire ant worker.

## Turfgrass Insects

Insect and Description	Life History and Habits	Susceptible Plants	Damage Caused	Method of Detection
<p><b>White grubs,</b> <i>Cyclocapaha</i> and <i>Phyllophaga</i> spp. Larvae or grubs about 1 to 1 1/2 inches long when fully grown, C-shaped when at rest with many folds or wrinkles in front half of body. Rear of body often slightly larger in diameter than rest and may be bluish or blackish in color. White grubs have a brown head capsule and three pairs of conspicuous legs. (Grubs of the billbug are legless). Adults of white grubs are commonly called May beetles, June beetles or June bugs. They are a little over 1/2 inch long and yellowish-brown with a reddish head.</p>	<p>The common species of <i>Cyclocapaha</i> attacking turf in Arkansas have a one-year life cycle while most of the <i>Phyllophaga</i> spp. have two-year life cycles. Few recordings of three-year life cycle grubs have been made in Arkansas. The larvae approach maturity about October. The <i>Phyllophaga</i> adults emerge from the ground from April to August depending on species. The adults of the annuals emerge from the soil from June through July. Little feeding appears to take place during the winter or early spring.</p>	<p>All grasses.</p>	<p>White grubs feed beneath the soil surface on the roots of grasses. Aboveground symptoms are a browning and dying of the grass in localized spots or in large, irregular shaped areas. Where infestations are heavy, the grass roots may be entirely eaten away as well as the grass blades and the turf may be rolled back like a carpet. Damage may be severe in September and October when the grubs are reaching maturity and the growth of bermudagrass is slowing down.</p>	<p>Examine the soil around the grass roots. Dig in brown areas near the edge of green, healthy areas of grass. If more than one grub per square foot of area is found, the lawn should be treated. If the soil is dry, you may need to dig 6 to 10 inches deep to find larvae.</p>
<p><b>Sod webworms,</b> <i>Crambus</i> spp. Larvae slender, grayish, black-spotted caterpillars about 3/4 inch long when full-grown, rather sluggish in their activity. Moths whitish or buff-colored. Wing span slightly over 1 inch. One species with white or silver stripe along margin of forewing, others without stripe. Wings folded close to body when at rest giving slender appearance.</p>	<p>Moths hide during day in grass and shrubbery, fly over grass at dusk. Eggs are laid on the leaves and crown. Larva hatch in a few days and begin to feed. They feed at night and hide during the day in shelters constructed of bits of grass and debris. Moths begin flying in April or May in warm areas and breeding continues through October. There may be 3 or 4 generations per year with broods overlapping.</p>	<p>All grasses. Bent and blue grasses most susceptible to injury, especially new lawns.</p>	<p>Larvae feed on grass blades, growing tips and greener portions of crown, but not on the roots. Damaged areas appear as scattered irregular, brown patches in turf.</p>	<p>Pyrethrum test. Treat when 16 or more larvae are found per square yard. Preventative treatments are suggested for newly planted lawns.</p>
<p><b>Cutworms,</b> <i>Nepheleodes minians</i> Guenee, <i>Feltia subterranea</i> (Fab.), <i>Peridroma saucia</i> (Hubner), <i>Agrotis ipsilon</i> (Hufn.). Thick-bodied caterpillars 1 to 2 inches long when full grown. Usually dull-colored, greenish, gray, brown or blackish; often with spots or longitudinal stripes. Adults are night-flying moths, dull or somber colored and with a wingspan of 1 1/4 to 1 1/2 inches.</p>	<p>Moths fly at night and lay eggs on leaves of grasses or nearby plants. Larvae feed at night and hide in holes, under debris or in mat of organic matter at the surface of the ground during the day. Breeding continues throughout the warm months of the year, and there may be several generations per season with overlapping broods.</p>	<p>All grasses.</p>	<p>Cutworms feed on the leaves and crown and may cut off plants near the soil line. Only the larvae are injurious.</p>	<p>Pyrethrum test. Treat when 5 or more cutworms are found per square yard.</p>

## Turfgrass Insects

Insect and Description	Life History and Habits	Susceptible Plants	Damage Caused	Method of Detection
<p><b>Armyworm</b>, <i>Pseudaletia unipuncta</i> (Haw.), and <b>fall armyworm</b>, <i>Spodoptera frugiperda</i> (J.E. Smith). Large, active caterpillars up to 1 1/2 inches long when full grown. Both species have longitudinal stripes on the body. Adults are dull colored, night-flying moths with a wingspan of 1 1/4 to 1 1/2 inches.</p>	<p>Larvae may feed day and night but are more active after dark. They may migrate into lawns from nearby fields or pastures. The true armyworm has 3 or 4 generations per year but is usually found in turf only in the spring. Fall armyworms have several generations from July to November and may damage turf in the fall.</p>	<p>All grasses.</p>	<p>Armyworms feed on the leaves and crown of grasses. Only the larvae are injurious.</p>	<p>Pyrethrum test. Treatment may be needed when 5 or more armyworms are found per square yard.</p>
<p><b>Leafhoppers</b>, many species. Small active insects 1/8 to 1/4 inch long. Adults whitish green, yellow or brownish-gray. May be speckled or mottled. Adults fly or jump short distances when disturbed. Nymphs are various colors as adults, but without wings. Nymphs have characteristic habit of moving sideways or backwards when disturbed.</p>	<p>Adult females insert eggs into tissues of the host plant. Eggs hatch in a few days in warm temperature. Several generations may occur in a season</p>	<p>All grasses.</p>	<p>Both adults and nymphs suck juices from the leaves and stems of grasses. Symptoms are a bleaching or drying out of the grass.</p>	<p>Examine areas in the lawn that look bleached or dry, also the surrounding green areas. Look closely for the small, wedged-shaped, jumping or flying adults as you walk. Also look closely on the leaves and stems for the nymphs that move sideways or backwards when disturbed.</p>
<p><b>Chinch bug</b>, <i>Blissus</i> spp. Adults are about 1/5 inch long, black with nearly all white wings that are folded flat over the body. There are both long and short-winged forms. The young are bright red but turn black as they approach the adult stage.</p>	<p>There appear to be at least three generations a year, with all stages present in any month. The highest populations occur during the summer. At this time, development from egg to adult takes about 6 weeks.</p>	<p>Only St. Augustine grass is seriously damaged.</p>	<p>Yellowish to brownish patched in lawn.</p>	<p>Close examination of damaged and adjacent areas. Flotation, as described earlier under detection and survey techniques, can be used to find chinch bugs.</p>
<p><b>Clover mite</b>, <i>Bryobia praetiosa</i> Koch, is about 1/30 inch in length with long front legs. Its body is somewhat depressed and is reddish-brown to greenish in color. The legs are amber to orange colored.</p>	<p>This mite is often concentrated in turf next to the foundation of a building. They are active during spring and fall when daytime temperatures are below 70 degrees F. They overwinter as eggs in the turf. Damage is not often serious, but they can become a nuisance pest by entering homes.</p>	<p>Grasses and various weeds.</p>	<p>Damage may occur from 1 to 3 feet out from buildings. Feeding causes the turf to become silvery because of the extraction of plant sap and the drying of cells.</p>	<p>Close examination of the leaves for stippling, speckling, silvering, and drying, plus the presence of mites and mite eggs. Also check nearby tree trunks and walls.</p>

## Turfgrass Insects

Insect and Description	Life History and Habits	Susceptible Plants	Damage Caused	Method of Detection
<p><b>Bermudagrass mite</b>, <i>Eriophyes cynodontiensis</i> Sayed. Extremely small (can barely be seen with a 10X hand lens), white, worm-like mites. Have two pairs of legs near head end. Females lay spherical, transparent eggs singly or in groups. Also called Eriophyid mite.</p>	<p>Little is known of the life history of this pest, but it is thought to overwinter beneath the leaf sheaths in the crowns of the bermudagrass plants. The females begin laying eggs beneath the leaf sheaths of the new growth in the spring. Breeding continues during the warm part of the year, and several generations occur during the season. The mites suck juices from the stems and inside of the leaf sheaths.</p>	<p>Common and hybrid bermudagrasses.</p>	<p>Shortening of stem internodes resulting in a stunted, rosetted or tufted appearance of the plants. With heavy infestations the grass turns brown and dies. When infestations are allowed to persist, the grass may be thinned out allowing the growth of weeds.</p>	<p>Look for plants with a stunted, rosetted or tufted appearance. Pull leaf sheaths away from stems. Examine inside of leaf sheaths and exposed stems with 10X to 20X hand lens or dissecting microscope. Look for mites and spherical, transparent eggs.</p>
<p><b>Spider mites</b> of the Family Tetranychidae are about 1/50 inch long, globular in shape and reddish, yellowish or greenish in color. The two-spotted mite has a pronounced dark spot on each side of the body. The Banks grass mite can also damage lawns in Arkansas.</p>	<p>Spider mites lay eggs on grasses, oxalis or other plants in lawns. Some species spin fine webbing that may entirely cover the grass in spots, especially in protected areas near curbs, walls or planter boxes. Spider mites breed throughout the warm months of the year producing several generations per season.</p>	<p>All grasses, clovers, oxalis</p>	<p>Mites feed by puncturing the leaves and sucking out the juices. First symptoms of this injury appear as a speckling or stippling of the leaves. This is followed by a yellowing, bronzing or bleaching and drying of the leaves.</p>	<p>Close examination of the leaves for stippling, speckling, yellowing, bronzing, bleaching, drying, webbing, plus the presence of mites and mite eggs. (A hand lens or low power microscope may be necessary to see the mites and eggs.)</p>
<p><b>Billbugs</b>, <i>Sphenophorus parvulus</i> (Gyll.) and <i>S. venatus vestitus</i> (Chitt.). The larvae of billbugs are white, legless grubs from 1/4 to 3/8 of an inch long when full-grown. The adults are small, black or brown weevils or "snout" beetles.</p>	<p>Little is known of the billbug's life history. Adults can be found throughout the year and in many areas larvae can also be found.</p>	<p>All grasses, but mainly bermudagrass.</p>	<p>Billbug larvae or grubs feed beneath the ground on the roots of grasses. Aboveground symptoms include the browning and dying of grass in spots or sometimes large areas.</p>	<p>Examine the soil around the grass roots. Dig in the edges of brown areas near green, healthy grass. If more than one grub per square foot is found, the lawn should be treated.</p>

## Turfgrass Insects

Insect and Description	Life History and Habits	Susceptible Plants	Damage Caused	Method of Detection
<p><b>Shorttailed cricket,</b> <i>Anurogryllus arboreus</i> Walker. Adults are brown and about 3/4 inch long and resemble pale field crickets except for the short ovipositor. Nymphs resemble adults but are smaller and lack wings.</p>	<p>This cricket overwinters as large nymphs and becomes adult in the spring. Mating and egg laying occurs in late spring or early summer. Young nymphs stay in the burrow in which they hatch, but larger nymphs leave and construct their own burrows. There is one generation per year. Most activity occurs at night.</p>	<p>Grasses and weeds.</p>	<p>Crickets feed on grass blades but damage is usually negligible. Burrow construction produces unsightly mounds of small soil pellets in lawns. These are especially noticeable in the fall as they reappear after each rain.</p>	<p>Observation of mounds of small soil pellets or soil deposits "similar" to crayfish activity. Treatment provides only partial control. Control is seldom needed unless large numbers of mounds are encountered.</p>
<p><b>Frit fly,</b> <i>Oscinella frit</i> (L.). Adult frit flies are slightly more than 1/16 inch long, shining black with small yellow markings on the legs. The eggs are pure white, 1/32 inch long, with a finely ridged surface. Mature larvae are 1/8 inch long, yellow, with black, curved mouth hooks. Pupae are yellow at first, then turn dark brown and are slightly less than 1/8 inch long.</p>	<p>The winter is passed in the larval stage in the stems of grasses. Pupation takes place in the spring and the first adults emerge about March. Eggs are laid on the leaves and leaf sheaths of grasses. Several larvae may occur in one plant. There are at least three broods. The activity of the last extending into October in warmer areas.</p>	<p>All grasses. Bent and blue-grasses are most susceptible to injury.</p>	<p>The larvae tunnel in the stems near the surface of the soil causing the upper portion of the plants to turn brown and die. Damage is most common on golf greens. Injury appears first on the collars of greens and moves in toward the center. The high or upper sections are usually the first to show symptoms. Greens with high organic matter content appear most susceptible.</p>	<p>Look for small, black adult flies hovering close to the grass from mid to late morning. Look for the larvae in the stems near ground level. A hand lens or dissecting microscope is useful in finding the very small larvae.</p>
<p><b>Ground pearls,</b> <i>Margarodes</i> spp. Females are wingless, pinkish scale insects with well-developed forelegs and claws, about 1.6 mm long. Males, considered rare, are gnat-like and vary from 1 mm to 8 mm in length. Clusters of pinkish-white eggs are enclosed in a white waxy sac. Nymphs, called ground pearls, have a globular, yellowish purple shell. Most cysts are 0.5 to 2.0 mm in diameter.</p>	<p>The life cycle is not completely understood. They overwinter in the cysts. Females mature in May, emerge from the cysts, and after a short mobility period, secrete a waxy filament that covers the body. They remain about 2 to 3 inches deep in the soil and deposit eggs within the waxy coat. Egg laying begins in June and continues into July, with the hatch extending into August. Young crawlers start feeding on grass roots and develop the globular appearance. There is usually one generation per year, but under unfavorable conditions two to three years may be required to complete a life cycle.</p>	<p>All turfgrasses.</p>	<p>Nymphs extract sap from the roots. The damage appears as irregular patches. During summer dry spells, the grass yellows, browns and usually dies by fall. Cysts are present in larger numbers at the interface between damaged and healthy grass.</p>	<p>Examine the soil around the grass roots. Dig in the areas near green healthy grass. Ground pearls can be found as deep as 10 inches in the soil (a depth that reduces the possibility of developing practical means of control).</p>

Turfgrass Insects				
Insect and Description	Life History and Habits	Susceptible Plants	Damage Caused	Method of Detection
<p><b>Skipper</b>, <i>Atalopedes campestris</i>. Larvae about 1 inch long and brownish-yellow in color. First two body segments behind head smaller than rest, giving appearance of a "neck." Adults are small butterflies with wingspan of a little more than 1 inch. Males have orange-yellow wings spotted with black; wings of the female are dark brown with orange-yellow spots.</p>	<p>Female butterflies lay eggs on turfgrass leaves and on other ornamental plants during the warm months. Adults feed on nectar from various flowers. Lantana is a favorite. There may be several generations per year.</p>	<p>All grasses, especially bentgrasses. (<b>Note:</b> Not extremely common to find damaging populations of this pest).</p>	<p>Larvae feed on leaves and crown.</p>	<p>Pyrethrum test. Treat when 10 or more larvae are found per square yard.</p>
<p><b>Red Imported Fire Ant</b>, <i>Solenopsis invicta</i>. Red imported fire ants are 1/8 to 1/4 inch in length and are reddish brown to black. They are social insects and live in colonies that may have up to 200,000 individuals. Fire ant colonies are made up of a queen ant, winged males and females (virgin queens), workers and brood (eggs, larvae and pupae). The head of the red imported fire ant large worker is not wider than the abdomen. Red imported fire ant nests are rounded and conical; however, in sandy soil the conical mounds of imported fire ants do not maintain their shape.</p>	<p>Winged reproductives mainly leave the fire ant colony on mating flights in late spring and summer, although swarming may occur at any time of the year. Fire ants mate during flight, and the females land to begin a new colony. Most females fly or are blown less than one mile from the nest. Nests are normally prevalent in open, sunny areas. In freshly invaded areas, there may be several hundred small, new nests per acre.</p>	<p>N/A</p>	<p>The red imported fire ant is a small, aggressive ant that causes damage difficult to measure in dollars. In landscaped areas, its large mounds are unsightly and may cause damage to lawn maintenance equipment. Its painful, burning sting results in pustules that may take up to ten days to heal. If broken, the pustule may become infected. Some people have allergic reactions to fire ant stings.</p>	<p>Visual observation or use of bait stations baited with a protein bait (piece of hot dog).</p>



## Turf Insect Occurrence in Arkansas

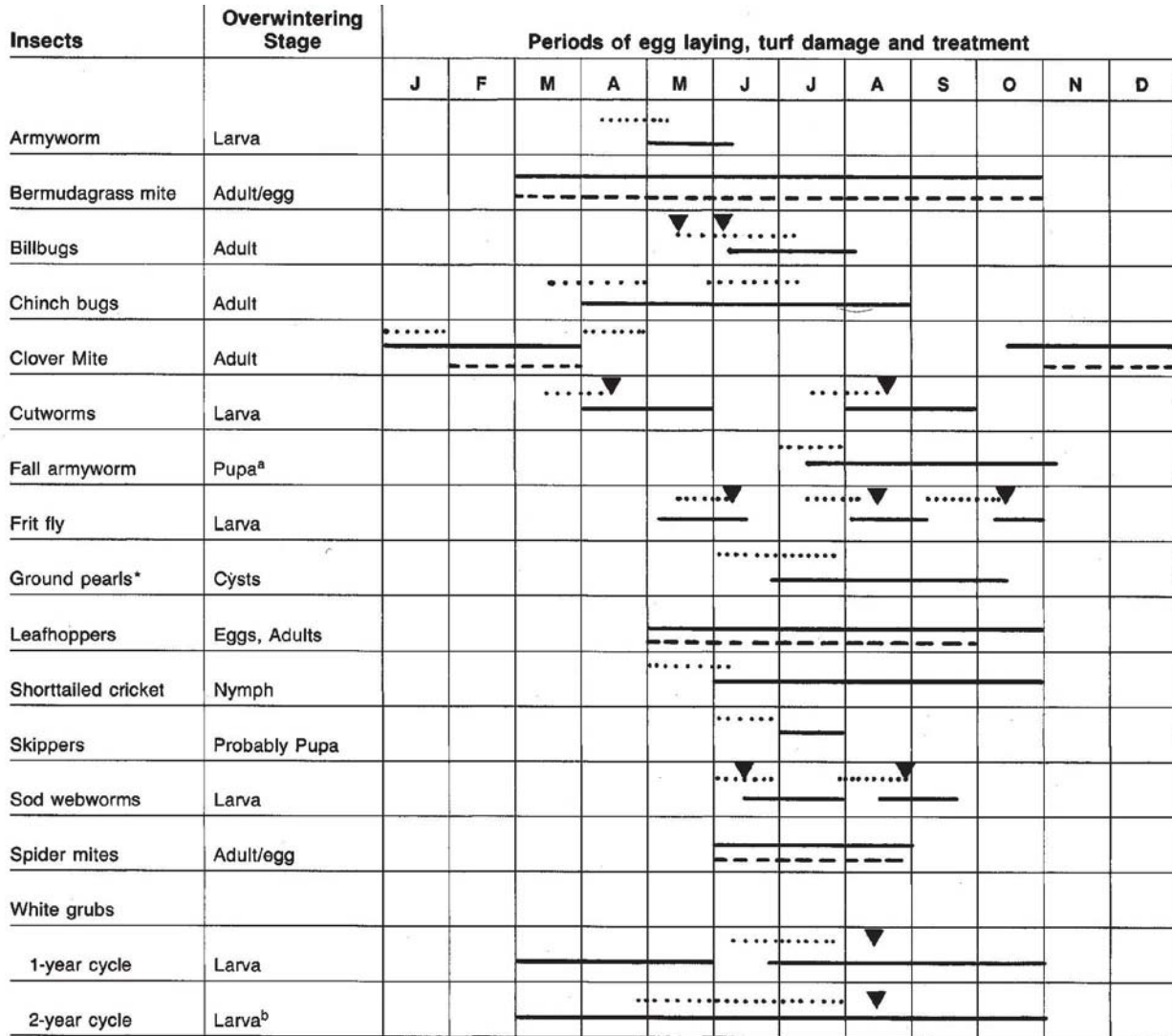

<sup>a</sup>Infestations from migrating moths from the South.  
<sup>b</sup>Several spp. involved thus extending egg laying.  
 \*No effective chemical control available.

..... Period of egg laying  
 ——— Period of damage by immatures  
 - - - - - Period of damage by adults

▼ Probable Treatment period for damaging stage. Some activity periods are not marked with a treatment indicator because damaging population may occur anytime throughout the period.

# Vertebrate Pest Management

Problems with vertebrate pests rarely approach the magnitude of the problems caused by weeds, diseases, weather and insects. Under certain circumstances, however, vertebrate pests problems can be significant and difficult to deal with. Specific questions about laws regulating vertebrate pest control should be directed to the Arkansas Game and Fish Commission, 2 Natural Resources Drive, Little Rock, Arkansas 72205, 800-364-4263 or 501-223-6300, [www.agfc.com](http://www.agfc.com). The following information will offer some basic guidelines for determining if vertebrates are a problem and how to control them if they become a problem.

## Factors Affecting Control

Several factors complicate the control of vertebrates, including:

- **Mobility.** Certain mammals and birds may come from long distances to damage crops. They may spend most of their time where they are not a problem.
- **Unpredictability.** Many factors, such as population density, weather and availability of natural food, influence the transition of a normally harmless vertebrate population into the role of a pest problem.
- **Public perception.** The public holds most vertebrates, especially larger ones such as geese or deer, in high esteem. Efforts to control them can then become a complex social problem as well.
- **Legal status.** Most mammals and birds are provided some protection under state and/or federal law as game animals, migratory birds or endangered species. You need to be aware of the species involved in damage and the legal restrictions relative to controlling it.
- **Control techniques.** Often because of environmental complications or the legal status previously mentioned, control techniques are limited for vertebrate problems. Control may incorporate cultural practices or physical barriers, which admittedly break down under some conditions.

In a turfgrass environment in Arkansas, some vertebrate pests that may occur include moles, skunks, armadillos and geese. All except moles and armadillos are protected under Arkansas and/or federal wildlife laws. The Arkansas Game and Fish Commission should be consulted for appropriate legal aspects concerning relief from nuisance animals.

## Moles

The eastern American mole is the only mole of concern in Arkansas. Moles are not rodents. They live underground preferring moist soil. Moles are 4 to 9 inches long and have a rather short tail. Though rarely seen aboveground, the eastern mole can be distinguished from other small mammals by its soft velvety fur and huge, flattened front feet that are equipped with large, broad claws for digging. Eyes are tiny, like a pinhead, and the tail and feet are usually pink. Moles have no visible ears. Earthworms and insect larvae/grubs are their main food source.

Moles owe their status as pests to the feeding tunnels they construct as they burrow in the surface of lawns and golf courses. Moles dig two kinds of tunnels. The feeding tunnel is made only an inch or two below the surface of the ground by the mole "swimming" through the loose topsoil. This kind of runway leaves a ridge of earth on the surface of the ground. The tunnels interfere with mowing and expose roots to air, sometimes killing grass or other plants. More permanent tunnels are made 6 to 10 inches below the surface, and mounds of earth are thrown up at intervals. From the main tunnel of the mole run, a short shaft extends straight up to the surface. The soil that is expelled from this vertical shaft wells up like water, and successive loads form a nearly circular mound of which there may be "ripple marks" in the form of complete circles.

Toxic baits and fumigants are available for controlling moles; however, these control measures often are not very effective. Toxic baits are often based on peanuts, grain or other food items that are not the moles' preferred food. Moles seldom take poisonous baits. Fumigants may be inserted in surface feeding tunnels and may kill moles if they happen to be in the tunnels at the time of the

treatment. When the use of poisons seems to be effective, the user has probably either frightened the mole out of his present runway by the scent or has killed the food upon which the mole feeds. If moles are deprived of their food supply, they will be forced to seek another area. Several insecticides are capable of reducing populations of earthworms and soil insects to a point where the soil no longer provides sufficient food to fulfill the mole's daily requirements. The effect on the moles cannot be expected for several weeks, and moles can cause increasing damage as they search in a decreasing food supply.

## Mole Control Techniques

The most effective method for controlling moles is the use of lethal traps, though this method is also time consuming. Traps must be carefully placed so as not to arouse the suspicions of moles, which are very sensitive to unnatural changes in their environment.

To establish which tunnels are active, step down on tunnels in several places in the yard. Mark the tamped area with a peg or wire flag. If the tunnel has been pushed back up in a day or so, set the trap in that section of the tunnel. Seek a long, straight runway for setting the trap.

Three trap types are the harpoon, scissor-jawed and choker loop. The scissor-jawed and choker traps require digging and exposing the tunnel. The jaws or loops are set to encircle the tunnel and are triggered when the mole moves through the trap. The harpoon trap is set directly over the runway, so that the supporting stakes straddle the runway and its spikes go into the runway. The trap is triggered when the mole's tunneling activity causes the soil to strike the pan and trigger the spikes. Set the trigger pan where it just touches the earth where the soil is packed down. Setting the trigger too high or too low will result in misfires. If any of these traps fail to catch a mole after two or three days, move the trap to a new location.

When using traps:

- Place a plastic pail with a warning sign over each trap.
- An average set will require three to five traps per acre.
- Check the traps every day.

## Skunks

The striped skunk is the species most commonly encountered in Arkansas. They are black in color with distinctive white stripes that extend laterally over the back. The adults normally weigh about 6 to 8 pounds and are 24 to 30 inches long. Skunks have short, stocky legs and disproportionately large feet equipped with well-developed claws for digging. Skunks are usually active from early evening through most of the night. During the day, they usually sleep in dens under logs, woodpiles or buildings.

The high nuisance value attributed to skunks is caused by their habit of burrowing in flowerbeds, lawns and golf courses in search of food. Skunks are carnivores and eat insects such as grasshoppers, beetles and crickets, as well as mice, moles, young rabbits, grubs, bees, wasps and their hives. Skunks also eat fruits, some grasses, leaves, buds, roots, nuts and grains. Insects, however, are a preferred food and skunks often tear up and destroy turf during their search for white grubs and other insect larvae. Digging normally appears as 3- to 4-inch, cone-shaped holes or patches of overturned sod. This grubbing activity is most common in the spring and fall when larvae are found near the soil surface.

Skunks are classified as furbearers and, as such, are protected in Arkansas by state regulations. A hunting license is required from the Arkansas Game and Fish Commission for either live trapping or administering lethal methods of control. With a hunting license, skunks may be live-trapped or killed during furbearing season. If skunk problems need to be handled outside furbearing season, a depredation permit is required. Contact the Arkansas Game and Fish Commission for information on obtaining this permit. Note that a depredation permit does not include permission to shoot skunks when local law prohibits discharge of firearms.

Skunks can carry rabies. Skunks that are overly aggressive or show abnormal behavior should be treated cautiously. The Arkansas Department of Health suggests that any skunk observed during daylight is acting abnormally and should be destroyed to prevent the spread of rabies. Contact the local animal control or sheriff's office for assistance with disposing of a rabid skunk.

Avoid shooting or striking the head to protect against damaging the brain for testing rabies. Keep in mind that most skunks will release their scent when shot, so try to avoid shooting them near buildings. If removing a potentially rabid skunk, gloves and/or shovels should be used. Place skunk in a sealed plastic bag and bury the carcass where pets will not dig it up.

## Skunk Control Techniques

Removal and relocation in combination with exclusion methods oftentimes is the best option for addressing skunk problems. Shooting is also an option, where legal, with proper hunting license or depredation permit. There are no toxicants or repellents registered for skunks.

Typically, skunk problems involve removing and excluding skunks from a den site. Avoid skunk removal from May through early August when den-bound, immobile young may be present. A combination of live trapping, relocation and exclusion are recommended as follows:

- **Live trapping.** Bait live traps with a few tablespoons of pet food having a fish base. When using a wire cage trap, place a tarp or plywood shell around the cage. Check the trap frequently particularly in the summer, as skunks could die from excessive heat and lead to accusations of inhumane treatment. After a skunk is trapped, cover the opening so the skunk cannot see. With a minimum of jarring or shaking, the trapped skunk can be transported and released with little concern for a musk discharge. Leg-hold traps can be used to catch skunks, but because of odor problems, this method should not be used near housing.
- **Relocation.** When relocating skunks, transport them at least 10 miles and release in habitat far from human dwellings.
- **Exclusion.** Typically, more than one skunk occupies a denning site. Seal off all foundation openings except one. Cover openings with wire mesh, sheet metal or concrete. Skunks may dig to gain entry, so obstructions such as fencing should be buried 1 1/2 to 2 feet. In front of the remaining opening, spread a layer of flour on the ground.

Typically, skunks are active at night. Check at night for tracks indicating the skunks have left the den and then seal the opening. To ensure no skunks are sealed inside, use one or both of the following approaches:

- o For several successive nights, unseal one opening at dark and place flour on the ground. After a couple of hours, check for tracks exiting the den and reseal the opening. If no tracks are detected after several nights, seal the opening permanently.
- o Place a trap inside the sealed up area. Bait with pet food and water. Remove and translocate any trapped skunks. Repeat until no skunks are trapped on successive days.

## Odor Abatement

When a skunk raises its tail, it is a warning. When a skunk's hind legs begin hopping, leave the vicinity as quickly as possible. Ordinarily, there is no discharge. But, if a skunk believes it is in danger, one discharge will not empty the reservoir. Many people find the odor repugnant or even nauseating. Because of its persistence, the scent is difficult to remove. Diluted solutions of vinegar or tomato juice can have limited effectiveness when applied to pets, people or clothing. Clothing can be soaked in weak solutions of household chlorine bleach or ammonia, but oftentimes the clothing is also ruined using this treatment. For spraying under foundations or structures, a number of skunk deodorizers are on the market. These offer some relief by masking, rather than removing, the odor.

## Armadillos

The armadillo is mainly nocturnal during the summer and may be diurnal during the winter. It digs burrows that are usually 7 to 8 inches in diameter and as much as 15 feet in length. The burrows are located in rock piles and around stumps, brush piles and dense woodlands. More than 90 percent of the armadillo's diet consists of insects, but the animals also feed on lizards, frogs, snakes, bird eggs, berries, fruits and roots. An armadillo pursuing insects in the ornamental landscape or in turf will tear and uproot an area similar to skunks, but at somewhat deeper depths.

The young are born in a nest within the burrow. The female produces only one litter each year in March or April. The litter always has quadruplets of the same sex, and each appears identical since they are derived from a single egg. The armadillo has poor eyesight but a rather keen sense of smell. In spite of its cumbersome appearance, the agile armadillo can run well when in danger.

## **Armadillo Control Techniques**

Since most of the damage caused by armadillos is a result of rooting for insects and other invertebrates in the soil, an insecticide may be used to remove the food sources and make areas less attractive to armadillos. Also, trapping armadillos has proven to be a fairly successful elimination method. Armadillos can be captured in live or box traps such as the Havahart or Tomahawk. If bait is desired, use over-ripe or spoiled fruit. Other suggested baits are fetid meats or mealworms.

## **Geese**

Wild geese are a federally protected migratory species. Domestic geese, such as white geese and graylags, are not under the jurisdiction of the Arkansas Game and Fish Commission or the federal government. Because wild geese are federally protected, USDA Wildlife Services (501-362-5382, 870-673-1121) can provide the best information concerning alternatives for controlling geese problems. Resident Canada geese should be referred to the Arkansas Game and Fish Commission (800-364-4263).

Canada geese need a permanent body of water on which to land, escape, rest and roost. They also need suitable open feeding area that provides a place to land, has good visibility of the surrounding territory and has abundant tender young grass and other vegetation for feeding. Canada geese in Arkansas consists of both migratory and nonmigratory populations. Migratory birds nest in Canada and migrate south for the winter.

Most complaints about damage come from areas where birds congregate in public or private ponds and feed in mowed areas in parks and near beaches and on golf courses and lawns. Fecal droppings damage lawns and golf greens and can limit recreational use of the area. Fecal contamination of water may pose a local pollution problem, although

typically it is not a threat to human health. Geese defending their territory can injure people who come too close.

## **Goose Control Techniques**

### **Hunting**

Geese may be taken during declared open hunting seasons. Hunting, where safe and legal, is the preferred method of reducing nonmigratory waterfowl and, over time, may serve to decrease damage. Hunting also makes frightening techniques more effective. In some cases, local ordinances would need to be changed to permit hunting in non-traditional areas such as parks and golf courses. Special restrictions on hours and dates open to hunting can be implemented. Contact the Arkansas Game and Fish Commission for current information on waterfowl hunting regulations and seasons.

### **Discontinue Feeding**

Well-fed domestic “park ducks” and geese serve as decoys, encouraging wild birds to congregate in unnaturally high concentrations. Therefore, the first control measure should be to discontinue feeding.

### **Frightening**

Geese can be repelled by almost any large foreign object or mechanical noise-making device. Frightening devices should be in place before the start of the damage season to prevent geese from establishing a use pattern. To prevent birds from becoming accustomed to the frightening device, it should be moved every two or three days and used in varying combinations.

Visual repellents such as flags, balloons and scarecrows can be used at a density of one per three to five acres before waterfowl settle into the area. If birds are already present, an additional one or more visual repellents per acre may be necessary. Because geese can quickly acclimate to stationary visual repellents, reinforcement with audio repellents may be necessary. A unique “nonstationary” visual repellent on the market is a simulated floating alligator head for small ponds. However, the effectiveness of this product has not been studied.

Pyrotechnics, shell crackers or other noise-making devices can be effective if used before birds become established. A disadvantage is that

neighbors may not appreciate the loud noises that are produced. A less-invasive product on the market is a programmable electronic device that plays recorded goose alarm calls in random combinations. The recordings can be set to play at dawn and dusk using multiple speakers to create natural sound patterns of disturbed geese.

Dogs trained to chase waterfowl have been used to protect golf courses and orchards. In certain situations, they can be very effective, such as when geese become adapted to pyrotechnics and other forms of hazing. Dogs can be free running or on slip-wires, tethered, underground “invisible fence” or controlled by a handler. On one golf course in Oregon, a professional dog trainer used four border collies to frighten geese three to five times per day for the first several days. The geese soon left, and hazing diminished over time. The golf course purchased one dog to continue the program.

All applicable laws must be observed when using these devices, particularly those governing loud noises, discharging of firearms, use of pyrotechnics and use of free-ranging dogs. Note that nesting waterfowl cannot be harassed without a federal permit. In addition, flightless geese should not be harassed.

### **Habitat Modification**

There are several ways to make a pond and its surroundings unattractive to waterfowl. However, these practices may also degrade habitat quality for other wildlife and fish species, so use with caution. Constructing an abrupt 18- to 24-inch vertical bank at the water’s edge will deter geese. On levees or banks, use large boulder riprap, which geese cannot easily climb over. Eliminate emergent aquatic vegetation with herbicides or an aquatic weed harvester or temporarily drain the pond. If possible, allow woody brush to grow around shorelines.

On lawns or areas surrounding ponds, reduce or eliminate fertilizer applications so that grass is less nutritious for grazing waterfowl. If possible, increase grass height to 10 to 14 inches, especially along shorelines. Consider replacing large lawn areas with clumps of shrubs or trees, ground covers such as myrtle or less palatable grass species such as fescue. Planting trees will interfere with the bird’s flight paths, and shrubs reduce the birds’ ability to see from the ground. Landscaping

techniques that reduce birds’ view to less than 25 to 30 feet discourages grazing, especially if harassment programs are also used.

### **Exclusion**

Canada geese may be discouraged from using ponds by installing a 30- to 36-inch high poultry wire fence at the water’s edge. (This technique, however, is not effective for ducks.) Geese are reluctant to pass under a wire fence, so installing a single-strand fence or one made of Mylar flashing tape at a height of about 15 inches may discourage geese from entering an area. Good results have been reported using 20-pound test, or heavier, monofilament line to make a two- to three-strand fence in situations where aesthetics preclude the use of wire fencing. String the first line 6 inches off the ground, with each additional line spaced 6 inches above the preceding line. Suspend thin strips of aluminum foil at 3- to 6-foot intervals along lines to increase visibility of the barrier for wildlife and people.

To stop waterfowl from using lakes, ponds or reservoirs, construct overhead grids of thin cable visible to both humans and waterfowl. White or brightly colored cables may improve visibility. Because these materials are extremely light, several hundred feet can be supported between two standard, 5-foot, steel fence posts. Grids on 20-foot centers will stop geese, and grids on 10-foot centers will stop most ducks. When necessary, grid lines should be installed high enough to allow people and equipment to move beneath them. Excessive rubbing will result in line breakage, so grid wires should be tied together wherever lines cross. Attach lines independently to each post and not in a constant run, to prevent having to rebuild the entire grid if a line breaks. Polypropylene UV-protected netting can be used to provide total exclusion from a lake or pond. Support the netting with 0.19 inch, 7 x 19 strand galvanized coated cable on 20-foot centers.

### **Repellents**

Repellents can be effective for short-term control. Methyl anthranilate is a chemical that has taste and olfactory repellent properties that can be sprayed on turf. Other chemicals may be on the market as well. Once the repellent dries, it does not wash off the grass, even in heavy rain. However, mowing treated grass will expose untreated grass to

geese and reduce the repellent's effectiveness. One study of a product with methyl anthranilate indicated that treating the first 100 feet of turf from the water's edge reduced bird activity over the remainder of the area; therefore, treating the entire area was unnecessary. Additionally, methyl anthranilate was mixed and applied with the herbicide 2,4-D, which did not change its effectiveness of repelling geese. Repellents, when used in combination with other techniques, may help reduce goose damage to lawns, golf courses and other turf areas.

## Summary

The key to controlling nuisance flocks of geese is promptness and persistence. Methods of controlling damage will work only as well as their implementation. Once nuisance waterfowl are gone from an area, the area must be made unattractive to waterfowl so they will not return. As soon as one goose or duck lands, it should be frightened until it leaves. Otherwise, the bird will act as a decoy and attract others.

# Pesticide Application

## Pesticide Safety

Pesticide safety begins with selection of the pesticide to be purchased. Various considerations, including who is going to be exposed during and after application, ease of application, potential harm to the environment, toxicity of the pesticide, the pest to be controlled and the cost of the material, must be considered.

## Storage and Inventory

The first safety step is proper storage. Without proper storage, pesticides can be damaged due to weather or mechanical situations. Correct storage also decreases the chance of contamination between two different types of pesticides and decreases the chance of the wrong pesticide being used.

A good storage building should be constructed of nonflammable material. It should have a floor that will prohibit liquids and dry pesticides from penetrating and leaking through and yet provide for easy cleanup. The building should be well ventilated and lighted with temperature control to prevent freezing and excessive heat. All storage buildings should be well marked and locked. If possible, the building should be fenced to further keep unauthorized people away. The storage area should be supplied with detergent, hand cleaner and water; absorbent materials, such as absorbent clay, sawdust and paper to soak up spills; a shovel, broom and dustpan; and a fire extinguisher rated for ABC fires.

Inventory control includes obtaining a Material Safety Data Sheet (MSDS) for each pesticide stored and used. It is also good management to have a current label for each pesticide stored and used on the facility. Both the MSDSs and labels should be stored in location(s) that permit the workers and staff to easily obtain them at any hour. This usually means having duplicates of each MSDS and label and having two separate filing places. It is usually best to designate one or two persons to be responsible for inventory control.

## Applicator Safety

There are four areas of pesticide application that expose the pesticide user. The first is mixing/loading. Mixer/loaders must be aware that

this is usually the most likely area for personal contamination to occur. Simple steps can greatly reduce exposure during the operation. Proper equipment must be available for accurate mixing/loading operations. This includes, but is not limited to, proper measuring devices (containers/scales), hoses and cutoff valves, backflow valves and personal protective equipment (PPE).

The PPE can include a plastic apron, rubber or plastic gloves, rubber or plastic boots, arm protection (either with long sleeve shirts or disposable sleeves), leg protection, face shield, hat, respirator and disposable coveralls. Not all the above PPE is needed for all pesticides, and some can be used in place of others. Disposable coveralls can replace the leg and arm protection and the need for an apron. Regular, tight woven coveralls can replace disposable ones for certain pesticides if they are washed after each day's use. PPE can be determined from the label and MSDS for each pesticide used. When using pesticide mixtures, select the PPE for the most hazardous pesticide. The mixer/loader should be very aware of the fact that they **should not use leather or canvas gloves or boots**. These types of gloves and boots retain pesticide residues and cannot be cleaned.

The next area for safety is the application. Generally, the applicator should use the same PPE as the mixer/loader. Although most applications are made at times of low wind speeds and with booms that are not far from the ground, there is still a good potential for the applicator to be exposed to pesticide drift or vapors. Plus, the applicator will have available the necessary PPE in case the sprayer malfunctions.

Sprayer cleanup is the third area of safety concern. Persons cleaning the spray equipment should use the same PPE as the mixer/loader. The cleanup people should be extra aware of the initial rinse/wash water containing pesticides. This is more from the chronic toxicity standpoint than from the acute. They should be especially wary about walking around in water without proper foot protection.

The last segment of applicator safety is personal cleanup. Always clean up before eating, smoking or using the bathroom. Shower after working with



pesticides, preferably right after the job is completed or at the end of the day. Launder clothes separately from the family clothes. Before laundering, rinse the clothes by hanging on a line and hosing down with water. This gets a fair amount of pesticide out of clothes before washing. Use hot (140 degrees F) water and a strong detergent with a 12-minute wash cycle. After the wash is finished, remove the clothes and run another wash cycle to “rinse” the washer. All clothes used for pesticide applications should be air-dried. Do not dry clothes in a dryer because there is a chance of some pesticide residue being left on the dryer drum.

## **Turfgrass User Safety**

Whenever possible, pesticide applications to turfgrass areas should be applied to provide the maximum amount of time from application to use of the turf. This translates into not allowing access to treated areas until the sprays have dried or for 24 hours. Never spray a turf area and then permit people or pets to have immediate access.

One must realize that users of turfgrass areas will be doing things (picnicking, walking, sunbathing) that increase their exposure. The clothing worn by turfgrass users is not conducive to reducing chronic exposure. Their leather or canvas shoes can retain pesticide residues if they walk in areas that have been recently treated with pesticides. The residues are not easily removed; therefore, the users can get a small dose every time the shoes are worn. Likewise, persons going barefoot or sunbathing can come into direct contact with spray residues. Children often have direct contact with the grass. Therefore, do not permit access to areas that have been treated with pesticides until the sprays have dried or 24 hours has elapsed, whichever is specified on the pesticide label.

## **Wildlife Safety**

The use of pesticides on turfgrass must also take into consideration possible impact on wildlife. Many pesticides are toxic to fish and/or wildlife. Therefore, do not spray pesticides in or on water or under situations that can lead to fish and/or wildlife kills. Also, be careful that pesticides are not applied just before a thunderstorm or irrigation schedule. You do not want to wash the pesticide into the water system.

Many parks and golf courses have creeks and waterways. Be careful in the selection and use of pesticides in these aquatic areas. The applicator must also be careful not to permit sprays to drift or be carried into water that may be near the turf area.

## **Summary**

Both the turfgrass manager and the user of the turfgrass should be aware of the benefits and risks involved with pesticides. The immediate risks are from acute toxicity. If the mixer/loader, applicator and cleanup person use proper PPE and techniques, their risks are greatly reduced. The user of the turf area is at the “mercy” of the turfgrass manager. Once again, if the turfgrass manager has taken the proper steps, the risk to the turfgrass user is also greatly reduced. The chronic risk for each party is more difficult to determine. By using proper application techniques and PPE, the turfgrass manager will reduce the chronic toxicity problems to the workers. Likewise, if the turfgrass manager has taken proper steps during and after application of pesticides, then the chronic risks to the turfgrass users should be reduced.

These are just a few items for turf managers to be aware of when using pesticides. Responsibility does not stop with the production of turf – it includes people using the turf.

## **Pesticide Laws and Regulations**

There are many federal and state laws that regulate the use of pesticides. These laws must be followed to the best of your ability to ensure the proper results and to protect people and the environment from unnecessary dangers and contamination. The best way to meet most of these regulations is to follow the directions on the pesticide label. The label in itself is a “law,” and all directions on the label are to be followed. To do differently is to be in violation of the label and the law.

The state of Arkansas requires all persons purchasing and/or applying a restricted-use pesticide to be a certified applicator. Golf course turfgrass managers should be certified in the Golf Course Pest Control category. Turfgrass managers managing turf other than on golf courses should be certified in the Ornamental, Tree and Turf Control

category. Study material may be obtained from your local Cooperative Extension Service office. Testing is conducted by the Arkansas State Plant Board. Persons certified as commercial or noncommercial applicators are required to keep records of all pesticide applications. These records are to be kept at the office of the business for a minimum of two years. The records should contain the following: time and place of each application, name of applicators, legal land description, date used, tank mix, dilution rate (rate of carrier), quantity used, complete trade name and registration number of product used, target pest and use site.

There are several other laws and regulations that may affect a turfgrass manager. Check with the Arkansas State Plant Board, Arkansas Department of Labor, Arkansas Department of Health and local authorities to determine other regulations that may affect your business.

## **SARA, Title III, or Community Right-to-Know**

SARA stipulates that anyone having specific hazardous materials above a certain quantity must report the storage of those materials to the State Emergency Response Committee (SERC) and to the Local Emergency Planning Committee (LEPC). A list of the chemicals that must be reported can be obtained from your local Cooperative Extension Service office. Check with the LEPC on the various requirements of the act for the business. This act requires those who fall under it to develop an emergency response plan for accidents. This plan can be developed in conjunction with your LEPC. This is an area where a good storage inventory program will greatly assist the turfgrass manager.

## **Disposal**

This is the most unclear aspect of pesticide application. Disposal of metal, glass and plastic containers can best be handled by triple rinsing and pouring the rinsate into the spray tank. These containers can then be disposed of in a permitted landfill. For paper bags, empty contents into the spray tank, and then cut the sack so that the remaining material can be “shaken” into the tank. These bags can then be disposed of in the trash or taken to a permitted landfill. Some landfills have local ordinances against disposing of pesticide containers even if they are properly rinsed or cleaned, so check your local situation.

Disposal of excess pesticide tank mix material and water used for cleaning spray equipment is a very difficult problem. Presently, the only thing anyone will agree on is to apply excess tank mix and/or water used for cleaning spray equipment to sites that are listed on the pesticide label. This would include the sites just sprayed or similar areas.

## **Environmental Factors Affecting Pesticide Effectiveness**

Many factors determine the effectiveness of a pesticide program. Using the right pesticide and applying it correctly are the most important factors that determine the final outcome. However, there are some environmental factors that can have a negative or positive effect on pesticides. Environmental factors that affect pesticides can be divided into three (3) groups: climatic, plant and soil factors.

### **Climatic Factors**

Temperature affects the amount of time required for a pesticide to do its job. For example, when air temperatures are between 65 to 85 degrees F, a plant is rapidly growing and herbicides will be more effective. Long periods of cold or hot temperatures will slow down herbicide activity.

High humidity allows foliar-applied pesticides to enter a plant quicker than at low humidity. During a period of high humidity and moderate temperature is the optimum time to spray a pesticide that must be taken up by plant foliage.

Precipitation soon after a pesticide application may help or hurt the final results. A moderate (1 inch or less) rain just after a soil-applied pre-emergence herbicide or soil insecticide will move the product down into the soil where it is needed. A rain shortly after application of a foliar-applied herbicide or systemic fungicide will drastically reduce the level of control. Any pesticide that needs to be taken up through the turf foliage should not be applied if there is a good chance of rain within a few hours. The decision not to spray because of the possibility of rain must be made by the applicator.

Wind is definitely the most important climatic factor. Excessive wind does not have a direct effect on pesticide effectiveness; however, indirectly it is a major problem. Excessive wind (greater than

10 mph) distorts spray patterns and hinders the application of the pesticide. Using a drift control additive will help, but knowing when not to spray because of excessive winds is more important. Applying pesticides in the early morning or late evening hours may help avoid the more windy parts of the day.

## Plant Factors

For several pesticides, it may be necessary for them to enter the plant through the leaf surface (foliar-applied). The cuticle and wax on the surface of a leaf use barriers the pesticide must cross before it can enter the leaf. Older plants or plants under stress will tend to have thickened, waxy layers making the leaves harder to penetrate. It may be necessary to use a crop oil if you are making late season applications. There may be an abundance of leaf hairs on the leaf surface of certain plants. Spray droplets tend to stand up on the hairs and do not contact the leaf surface. The addition of a surfactant to the spray mix would help the spray droplet penetrate the hairs and allow the pesticide to come in contact with the leaf surface.

An important plant factor that influences herbicides is the growth pattern and growth stage of the plant. Each year weeds complete four stages of growth: seedling, vegetative, seed production and maturity. Annual and biennial plants are easiest to control at the seedling stage, but perennial plants can be more effectively controlled during their vegetative stage. Treating perennial plants at this stage allows for better control of the underground parts of the plant.

Location of growing points on a plant can affect their level of control. Applying an herbicide directly to the growing point will generally increase the effectiveness of the herbicide. Since grassy weeds have growing point(s) below the soil surface, it is difficult to apply an herbicide directly to the growing point. A broadleaf weed has an exposed growing point at the top of the plant and along leaf axils. Herbicides can be applied directly to growing points on broadleaf plants.

## Soil Factors

The texture and organic matter content of a soil has a definite effect on soil-applied pesticides. Soil texture depends on the percent of sand, silt and clay.

Soils high in clay content will tie up or adsorb soil pesticide particles, making them unavailable for effective pest control. Higher pesticide rates may be recommended on fine-textured clay soils. Sandy or silty soils do not adsorb very much of the pesticide making them more available for pest control. Lower rates of soil-applied pesticide can be used on coarse-textured sandy soils without sacrificing pest control (check the label for range of rates).

Arkansas has a wide variety of soil textures which range from very fine-textured clay soils to very coarse-textured sandy soils. Erratic pest control from a successful application of a soil-applied pesticide could very likely be attributed to the texture of the soil.

Soil organic matter content also has a dramatic effect on soil-applied pesticides, especially on organic products. Soils with 2 percent organic matter content or greater will require higher pesticide rates for successful pest control (check label for range of rates). High organic matter soils have a greater potential to tie up pesticides than any other soil factor. Most Arkansas soils have less than 3 percent organic matter.

Another factor that can affect a soil-applied pesticide is the pH of the soil. Some pesticides will be less effective in soils with a low pH (less than 6.0), while others are relatively unaffected by soil pH.

Pesticides can also be affected by the pH of the water that is used for mixing. Few Arkansas water sources contain what is termed "hard water." Hard water has an overabundance of calcium, magnesium and many other elements which increase the pH of the water. Mixing certain pesticides with water that has a high pH (8.0 or higher) can reduce their effectiveness. If applications of a pesticide have been producing erratic results in the past, it would be worth the time to check the pH of the water source. Since pH levels of any given water source fluctuate during the year, a pH reading should be taken as near to application time (month of application) as possible. If the water source has a pH level of 8.0 or higher, then a buffer should be added to each tank of water to lower the pH.

# Application Equipment

## Liquid Application

Most common pesticides are applied in a liquid form. They may be distributed as a liquid or powder but mixed with water, oil or some other liquid carrier for application. Some fertilizers are applied as liquids, so liquid application equipment has long been the standard for pesticide and fertilizer application. This equipment generally consists of several different types of boom and boomless (or broadcast) sprayers, which have unique characteristics.

## Boom Sprayers

Boom sprayers are sprayers which have nozzles arranged along a boom for uniform distribution of material. They vary in size, depending on the type of use. Some agricultural sprayers may have boom widths of 60 to 80 feet, while hand-held or push-type booms may be only 1 to 4 feet wide. When properly adjusted and calibrated, each type of sprayer can provide uniform coverage.

Turfgrass managers typically use boom sprayers on flat surfaces, such as fairways and greens. Large open areas, such as practice areas or wide fairways, can be sprayed with wide booms with little problem. Wide booms are difficult to maneuver in tight areas. If terrain is uneven, a shorter boom width is recommended for the best distribution.

## Boomless Sprayers

Boomless or broadcast sprayers are essentially the same as boom sprayers, except a single jet or multiple jet cluster nozzle replaces the boom. Boomless nozzles can be used to spray widths up to 40 feet. However, spraying wide swaths from a single nozzle makes uniform coverage difficult to obtain. Boomless sprayers are also extremely susceptible to drift, especially when operating at pressures over 40 psi. Boomless sprayers are not recommended for use on fairways and other areas where uniform coverage is needed. They are best suited for areas where boom sprayers are difficult to use, such as rough terrain, areas with many trees, fencerows and roadsides.

Spray guns, whether operated from manual (backpack) or powered sprayers, are another type of boomless sprayer. They are primarily used for ornamental plants and are not recommended for use

on turfgrass except for spraying areas less than 10 or 20 square feet. Operators should use boom sprayers with conventional nozzles whenever possible. Spray guns should only be used around shrubs, trees and areas where it is not feasible to use hand-held or push-type booms. Spray gun operators should strive for uniform coverage.

## Nozzle Types

Nozzle selection is one of the most important decisions relating to pesticide application. Nozzle type determines not only the amount of spray applied to a particular area but also the uniformity of the applied spray, the coverage obtained on the sprayed surfaces and the amount of drift. Each nozzle type has specific characteristics and capabilities and is designed for use under certain application conditions. Regular flat-fan, flooding flat-fan and boomless nozzle types are commonly used for ground application of turf chemicals.

Regular flat-fan nozzles are used for most broadcast spraying of herbicides and for certain insecticides when foliar penetration and coverage are not required. These nozzles produce a flat oval spray pattern with tapered edges. They are available in various standard spray fan angles and are usually spaced 20 inches apart on the boom at a height range of 10 to 23 inches.

Recommended boom heights for standard spray angles are:

Spray Angle (degrees)	Boom Height for 20 Inch Spacing (inches)
65	21-23
73	20-22
80	17-19
110	10-12

The normal recommended operating pressure range for regular flat-fan nozzles is 15 psi to 30 psi. In this range, this nozzle type will produce medium to coarse drops that are less susceptible to drift than finer drops produced at pressures of 40 psi or greater. Regular flat-fan nozzles (**Figure 7.1**) are also recommended for some foliar applied herbicides and fungicides at pressures of 40 psi to 60 psi. These high pressures will generate finer

drops for maximum coverage on the plant surface, but the possibility of drift increases significantly, so appropriate precautions must be taken to minimize its effects.

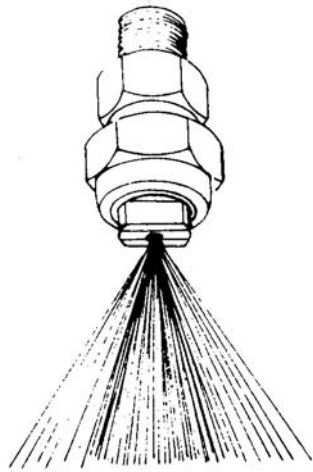

FIGURE 7.1. Regular flat fan.

Because the outer edges of the spray patterns of these nozzles have tapered or reduced volumes, nozzles must be carefully aligned and at the proper height, so adjacent patterns along the boom will overlap to obtain uniform coverage (Figure 7.2). The most effective pattern is achieved when this overlap is 30 to 50 percent of the nozzle spacing. Because of its ability to produce a very uniform pattern when correctly overlapped, the regular flat-fan nozzle is generally the best choice for broadcast application of herbicides.

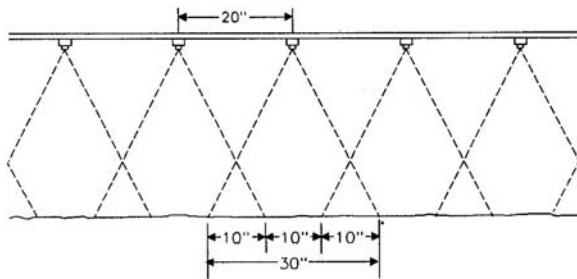

FIGURE 7.2. Fifty percent overlap.

LP or “low-pressure” flat-fan nozzles are available from the Spraying Systems Company. This nozzle develops a normal fan angle and distribution pattern at spray pressures from 10 psi to 25 psi. Operating at a lower pressure results in larger drops and less drift than the regular flat-fan nozzle designed to operate at pressures of 15 psi to 30 psi.

Flooding flat-fan nozzles produce a wide-angle, flat-fan pattern and are commonly used for applying herbicides and mixtures of herbicides and liquid fertilizers (Figure 7.3). The nozzle spacing on the boom for applying herbicides and fertilizers is generally 40 inches. These nozzles should be operated within a pressure range of 8 psi to 25 psi for maximum effectiveness and drift control. Changes in pressure will affect the width of the spray pattern more with this type of nozzle than with regular flat-fan nozzles. Also, the distribution pattern is usually not as uniform as that of a regular flat-fan tip. The most effective pattern is achieved when the nozzle is mounted at a height and angle to obtain at least double coverage or 100 percent overlap (Figure 7.4).

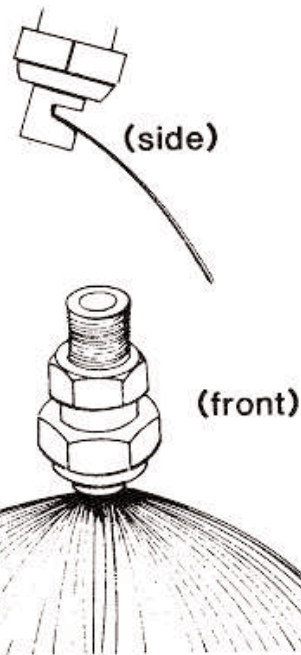

FIGURE 7.3. Flooding flat fan.

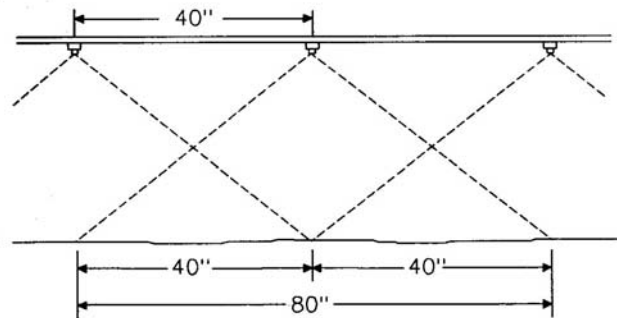

FIGURE 7.4. 100 percent overlap.

Flooding nozzles can be mounted so they spray straight down, straight back or at any angle in between. However, the most uniform coverage is obtained when the nozzle is oriented to spray at about 45 percent above the horizontal.

The flooding flat-fan nozzle is the best choice for applying a liquid fertilizer or a liquid fertilizer-herbicide mixture. Due to large droplet size, it is effective when applying straight herbicides in situations where drift is a problem. However, the nozzle does not produce as uniform a pattern as regular flat-fan nozzles. Regular flat-fan nozzles operated at low pressures (10 to 15 psi) should be used when drift is a problem and precise uniform coverage is required.

## Nozzle Material

Nozzle tips are available in a wide variety of materials, including ceramic, hardened stainless steel, stainless steel, nylon and brass. Ceramic and hardened stainless steel are the most wear-resistant materials but are also the most expensive. Both stainless steel and ceramic tips have excellent wear resistance with either corrosive or abrasive materials. Ceramic tips are more susceptible to breakage and are used less than stainless steel tips. Ceramic and stainless steel tips wear uniformly, so gradual pressure reduction during calibration will allow extended nozzle life.

Nylon tips are also very resistant to corrosion and abrasion. They are, however, subject to swelling when exposed to some solvents. Brass tips are the most common. They wear rapidly and less uniformly due to variations in material hardness when used with abrasive materials such as wettable powders and corrode easily with some liquid fertilizers. As brass nozzles wear or corrode, the orifice size changes, making calibration tables for these nozzles inaccurate. Each nozzle will wear or corrode at different rates, making it difficult to maintain boom spray uniformity or calibration. Wear and corrosion may also alter the spray pattern of nozzles. Brass tips are only economic when used on sprayers with very low annual use. For sprayers that have more extensive use, stainless steel or nylon tips are a better choice because of their longer wear life and uniformity of wear.

## Calibration

Calibration is the process of adjusting spray equipment to uniformly apply the desired rate of chemical. The performance of any chemical depends upon proper application of the correct amount on a given area. Most chemical performance complaints can usually be traced to errors in mixing or applying the chemical. The purpose of calibration is to ensure that the sprayer is applying the chemical uniformly and at the correct rate.

### Variables Affecting Application Rate

Three variables affect the amount of chemical mixture applied per acre:

- 1) the nozzle flow rate,
- 2) the ground speed of the sprayer, and
- 3) the effective sprayed width per nozzle.

To calibrate a sprayer accurately, the effect of each of these variables on sprayer output must be understood and controlled.

### Nozzle Flow Rate

The flow rate through the nozzle varies with orifice tip size and nozzle pressure. Installing nozzles with a larger or smaller orifice size is the most effective way to change the sprayer's output if major volume changes are required.

Changes in nozzle pressure should be used for minor increases or decreases of sprayer output, since pressure changes have significantly less effect than nozzle changes. It takes a four-fold increase in pressure to double nozzle flow rate. For example, to increase nozzle flow rate from 25 GPM at 20 psi to 50 GPM, pressure would have to be increased to 80 psi (4 x 20). Decreasing nozzle pressure can be used effectively to maintain an application rate due to nozzle wear. It should never be used to make major changes. Most nozzles work best at pressures between 20 psi to 40 psi. Lower pressures may distort the spray pattern, while higher pressures increase spray drift.

### Ground Speed

The spray application rate varies inversely with the ground speed. Doubling the ground speed of a sprayer reduces the gallons of spray applied per acre (GPA) by one half. For example, a sprayer applying 20 GPA at 3 MPH would apply only 10 GPA at a

speed of 6 MPH if all other factors remained the same. A sprayer calibrated at 4 MPH, but actually operated at 3 MPH, will overspray by 33 percent and significantly increase chemical costs and the potential for turf damage.

### **Sprayed Width Per Nozzle**

The effective width sprayed per nozzle also affects the spray application rate. Doubling the effective sprayed width per nozzle will decrease the gallons per acre (GPA) applied by one-half. For example, if the nozzle is applying 40 GPA on a 20-inch spacing, a change to 40-inch spacing will decrease the application rate to 20 GPA.

### **Precalibration Checks**

Before calibrating a sprayer, service the entire unit, check for uniform nozzle output and pattern and determine exactly how much liquid your sprayer tank holds.

### **Servicing**

Clean all lines and strainers. Make sure the strainers are in good condition and are the correct size for the type of chemical formulation to be applied. Inspect all hoses for signs of aging, damage or leaks and hose clamps for corrosion and adjustment. Check the pressure gauge to determine if it is working properly (is the pressure holding constant and does it read zero when the pump is shut off?). The accuracy of the gauge is not as important as its ability to give the same pressure reading each time it is produced. At least once a year, preferably at the beginning of the spraying season, check the gauge against another gauge known to be accurate. Also, boom pressure will be lower than remote mounted gauge pressure. To determine pressure loss, operate the sprayer at a known pressure, then install a gauge on one of the nozzle outlets on the boom and record the lower pressure. Check nozzle pressure at several operating pressures to develop a nozzle pressure table.

### **Nozzle Output and Pattern**

Check for uniformity of nozzle output and for consistency of spray angles, spacing and height. To check for uniform nozzle output, install the selected nozzle tips, partially fill the spray tank with clean water and operate the sprayer at a pressure within the recommended range. Place a container (for example, a quart jar) under each nozzle and check

to see whether all the jars fill in about the same time. Inexpensive calibration flow meters are available for direct readings of individual nozzle flow rates as a method to quickly check nozzle calibration. Replace any nozzle tips that have an output that varies more than 5 percent from the output of the rest of the tips or has an obviously different tan angle or distorted spray pattern. An effective way to determine whether a uniform pattern is being produced and whether the boom is at the proper height is to spray some water on a warm, dry surface, like a paved road or gravel drive, and observe the drying pattern. If the pattern is not uniform, some strips or areas will dry slower than others.

### **Tank Capacity**

Knowing the exact capacity of your sprayer's tank is necessary for accurate mixing of chemicals in the tank. The use of an inaccurate tank capacity when determining application rates is a common cause of under and over application. A tank thought to hold 200 gallons but which actually holds 250 gallons results in a built-in calibration error of 25 percent.

The best and easiest way to accurately determine tank capacity is to fill the tank using any convenient container for which an exact capacity is known. If container capacity is unknown, it can be determined by filling the container with water and then checking its weight (water weighs 8.33 pounds/gallon). Another effective way of measuring tank capacity is with an accurate flow meter. Flow meters should be checked for accuracy by weighing sample volumes taken over a given amount of time.

### **Measuring Ground Speed**

To apply chemicals accurately, ground speed must be constant. Field conditions, such as surface roughness, softness and slopes, will affect ground speed and significantly change application rates. Speedometers and tachometers are generally not a good means of determining ground speed as wheel slippage can result in speedometer reading errors of 25 percent or more. Changes in tire size can also affect speedometer readings. The most accurate way to maintain a constant ground speed is with a special sprayer speedometer that is run off a non-driven ground wheel. These speedometers are available from a number of spray equipment manufacturers and are a good investment if a

considerable amount of spraying is done. Some sprayer monitors have the ability to accurately measure ground speed.

If an accurate speedometer is not available, the next best method to establish a calibrated ground speed is to measure the speed of the sprayer at a variety of throttle and gear settings in an area that has surface conditions like those of the turf to be sprayed. To measure ground speed, stake out a known distance in the turf. Suggested distances are 100 feet for speeds up to 5 MPH, 200 feet for speeds from 5 MPH to 10 MPH and at least 300 feet for speeds above 10 MPH. At the throttle setting and gear to be used during spraying, determine the travel time between the measured stakes in each direction. To ensure the greatest accuracy, the sprayer should be at least half full of liquid. Average the two speeds and use the following equation to determine the ground speed.

$$\text{Speed (mph)} = d/t \times 0.682$$

“d” is the distance between the two stakes, in feet.

“t” is average time it took to drive between the stakes, in seconds.

The number, 0.682, converts feet per second into mph.

## Determining Sprayer Output

There are a number of ways to determine sprayer output. One of the easiest and most effective methods is the nozzle output method. The advantage of this method is that it is done with the sprayer stationary. In order to use this method, three pieces of information must be known:

**Operating pressure** – This will generally be in the 20 psi to 40 psi range depending on the type of nozzle used.

**Ground speed** – This speed will normally be in the 3 MPH to 8 MPH range depending upon conditions of the area to be sprayed.

**Sprayed width per nozzle** – Varies with the type of nozzle arrangement used, but effectively is the spacing between nozzles on the boom.

To calibrate a sprayer using this method, follow these steps.

**Step 1.** Fill the sprayer partially with water and operate it at the correct pressure. Use a container marked in ounces to collect the output of a nozzle

for 1 minute or some convenient fraction of a minute. Check all nozzles to determine the average number of ounces per minute (OPM) of output for each nozzle and for wear uniformity comparisons (very important for brass nozzles spraying wetttable powders).

**Step 2.** Convert the OPM determined in Step 1 to gallons per minute (GPM) by dividing the OPM by 128 (the number of ounces in 1 gallon).

**Step 3.** Select the ground speed (MPH) at which the sprayer will operate, normally 3 MPH to 8 MPH.

**Step 4.** Determine the sprayed width per nozzle (M, in inches. For broadcast spraying, “W” will equal the distance between nozzles).

**Step 5.** Once these values are known, the sprayer’s output in gallons per acre (GPA) can be calculated using the following equation:

$$\text{GPA} = \frac{\text{GPM} \times 5940}{\text{MPH} \times W}$$

“GPA” is the sprayer’s output in gallons per acre.

“GPM” is the nozzle output determined in Step 2.

“5940” is a constant used to convert inches, gallons per minute and miles per hour to gallons per acre.

“MPH” is the ground speed selected in Step 3.

“W” is the sprayed width in inches per nozzle that was determined in Step 4.

**Example:** A sprayer is set up to broadcast spray an herbicide with regular flat fan nozzles spaced 20 inches on center. A ground speed of 5 MPH has been selected. The average collected nozzle output is 54 OPM.

What is the application rate in gallons per acre?

$$\text{GPM} = \frac{54}{128} = 0.42 \text{ (Step 2)}$$

$$\text{GPA} = \frac{0.42 \times 5940}{5 \times 20} = 24.94 \text{ (Step 5)}$$

Under this set of conditions, the sprayer will apply approximately 25 gallons per acre. If this is not the application rate desired, then one or more



conditions will need to be changed. If only a small change is needed, this can generally be accomplished by either raising or lowering the pressure. Remember to stay within the pressure limitations of the nozzle being used. If a larger change is required, change ground speed or switch to larger or smaller nozzle tips.

## Calibration Jars

Calibration jars are available which further simplify the calibration process. These jars require that the following basic information be known or measured: pressure, ground speed, nozzle output and effective spray width per nozzle. They do, however, eliminate calculations involved by use of graduated charts on the calibration jars. Calibration jars are available from a number of sources and are effective when used according to the instructions that accompany them.

## Determining How Much Chemical to Put in Tank

To determine the amount of pesticide to add to the spray tank, the following must be known:

1. Recommended application rate of pesticide, from product label.
2. Sprayer tank capacity.
3. Calibrated sprayer output.

A key concern here is to know the exact tank capacity. The recommended application rate of the pesticide is given on the label. The rate is usually indicated as pounds of total product per acre for wettable powders and pints, quarts or gallons per acre for liquids. Sometimes the recommendation is given as pounds of active ingredient (pounds a.i.) per acre rather than the amount of total product per acre. The active ingredient must be converted to actual product.

## Dry Formulation

**Example:** A pesticide recommendation calls for 2 pounds of active ingredient (a.i.) per acre. An 80 percent wettable powder has been purchased. The sprayer has a 200-gallon tank and is calibrated to apply 40 gallons per acre. How much pesticide should be added to the spray tank?

**Step 1.** Determine the number of acres that can be sprayed with each tank full. The sprayer has a 200-gallon tank and is calibrated to apply 40 gallons per acre ( $200/40 = 5$  acres per tank).

**Step 2.** Determine the pounds of pesticide product needed per acre. Because not all of the product in the bag is an active ingredient, more than 2 pounds of the total product must be added for each “acre’s worth” of water in the tank. To determine how much more, divide the amount of active ingredient needed per acre (2 pounds) by the percent of active ingredients in the product (80% which equals 0.80).

Two and one-half (2.5) pounds of product ( $2 \text{ pounds a.i.}/0.80 = 2.5 \text{ pounds}$ ) will be needed for each “acre’s worth” of water in the tank to apply 2 pounds of active ingredient per acre.

**Step 3.** Determine the amount of pesticide to add to each tank full. With each tank full, 5 acres will be sprayed (Step 1) and 2.5 pounds of product per acre are required (Step 2); therefore, 12.5 pounds ( $5 \text{ acres} \times 2.5 \text{ pounds/acre} = 12.5 \text{ pounds}$ ) of product will need to be added to each tank full to obtain the desired application rate.

## Liquid Formulation

**Example:** A pesticide recommendation calls for 1 pound of active ingredient (a.i.) per acre. A pesticide that has 4 pounds of active ingredient per gallon has been purchased. The sprayer has a 150-gallon tank and is calibrated at 30 gallons per acre. How much pesticide should be added to the spray tank?

**Step 1.** Determine the number of acres that can be sprayed with each tank full. The sprayer has a 150-gallon tank and is calibrated for 30 gallons per acre ( $150/30 = 5$  acres per tank).

**Step 2.** Determine the amount of product needed per acre by dividing the recommended a.i. per acre by the concentration of the formulation. To apply 1 pound of active ingredient (a.i.) per acre, one-fourth gallon or 1 quart of product is needed for each “acre’s worth” of water in the tank ( $1 \text{ pound/acre} \times 4 \text{ pounds/gallon} = 0.25 \text{ gallons/acre}$ ).

**Step 3.** Determine the amount of pesticide to add to each tank full. With each tank full, 5 acres will be sprayed (Step 1) and .25 gallon (1 quart) of product per acre is required (Step 2). Add 5 quarts ( $5 \text{ acres} \times 1 \text{ quart per acre} = 5 \text{ quarts}$ ) of pesticide to each tank full.

## Granular Application

Granular application equipment is traditionally used to apply fertilizers, but many pesticides are now available in granular form. Application equipment for granular pesticides is somewhat different from that for fertilizers because the volume of material applied is usually considerably less and uniform distribution is very important.

### Equipment

Granular application equipment consists of drop, rotary and air spreaders. All of these consist of a hopper and some type of metering device. Granules are metered through orifices in the bottom of drop spreaders and fall directly to the ground. Since granules drop straight down, there is little chance for drift and distribution is more uniform. Drop spreaders usually have narrow widths and are not recommended for large areas. Also, since particles fall straight down, the edge of the pattern is well defined, and small steering errors will cause areas to be missed or doubled.

Rotary or centrifugal spreaders are the most common granular applicators. They are available in hand-powered or tractor-powered models. With this type of spreader, granules are metered through an orifice onto a rotating disk. Granules are deflected off of the disk into an approximate half circle pattern. Because granules are thrown away from the spreader, wider swaths can be attained and large areas can be covered quickly. The pattern is feathered on the edges, so steering errors are less critical.



FIGURE 7.5. Example of air spreader.

Air spreaders are popular in the agricultural market but are just now beginning to receive attention from turfgrass managers (Figure 7.5). Air spreaders meter granules through an orifice, or with a fluted roller, into a venturi cup where they are

suspended in an airstream and travel through hoses to deflectors mounted on a boom. At the deflectors, the granules are distributed in a pattern similar to that of a flat-fan nozzle. When properly calibrated, air spreaders can uniformly distribute materials over a wide range of application rates.

### Calibration

Chemical producers may provide information for settings on granular applicators, but these should be used only as a starting point. Manufacturers are as precise as possible with calibration guidelines, but there are several variables that must be measured for accurate calibration. Variables affecting granular application rates are ground speed, swath width and orifice size. Ground speed will vary on hand-pushed spreaders based on operator walking differences, so operators should calibrate spreaders. Swath width depends on the type of spreader, and uniform application of the pesticide is dependent on the operator's ability to maintain constant spacing between swaths. Orifice size is adjusted to distribute a certain amount of pesticide for a given speed and swath width. It cannot be accurately set if the operator does not maintain a nearly constant ground speed and swath width. Since different granules have different flow characteristics, granular applicators must be calibrated for each particular material.

One method for spreader calibration is to apply a known weight of material on a measured area (1,000 square feet for drop or 5,000 square feet for rotary) that is away from fairways or greens; then weigh the remaining material to determine exactly how much was applied. For safety reasons, this method is not recommended because pesticide may be over applied to an area causing contamination. A better calibration method is to lift the drive wheel of the spreader and spin it at the proper ground speed (approximately 3 MPH) while letting the granules fall on the floor or into a catch pan. This method works well for drop spreaders. The best method is to hang a catch pan under the spreader and push it a known distance and then weigh the material.

Rotary spreaders may be calibrated by lining up a row of shallow boxes or pans perpendicular to the line of motion (Figure 7.6). The row should cover 1.5 to 2 times the expected swath width. Put material to be spread in the hopper and make three passes over the boxes operating in the same direction on every pass. The material in each box can be

weighed to plot the pattern of the spreader. The effective swath width is determined by the following steps:

- Step 1.** Average 3 to 5 center boxes.
- Step 2.** Find the point on each side away from the center where the quantity in a box is half of the average found in Step 1.
- Step 3.** Measure the distance from the center of these two boxes for the effective swath width.

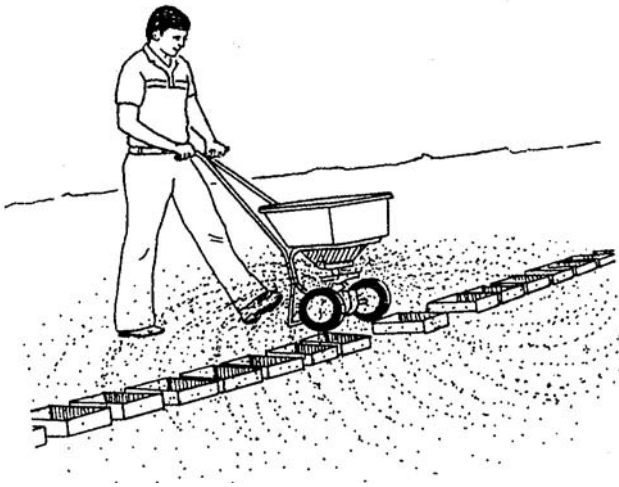

**FIGURE 7.6.** To make a quick pattern check, lay out a row of shallow cardboard boxes in a line perpendicular to the direction of travel.

If the two boxes used to determine effective swath width do not contain approximately the same amount of material, the pattern is not symmetric and the spreader is performing unsatisfactorily.

## Operation

Where possible, flags can be used to mark the effective swath width to help the operator achieve uniform coverage. If markers cannot be used, operators should focus on an object past the point where they will stop spreading to help make a straight pass.

When operating a spreader with an unacceptable pattern, the operator should reduce the application rate by half and go over the area twice. For best coverage the second passes should be perpendicular to the first passes. Small spreaders were designed to be pushed; unacceptable patterns occur when they are pulled. If conditions exist where the spreader is easier to pull than push, the spreader must be calibrated moving backwards.

# Selected Turfgrass References and Study Material

- Baker, J. R. 1982. *Insects and Other Pests Associated With Turf: Some Important, Common, and Potential Pests in the Southeastern United States*. North Carolina Agricultural Extension Service AG No. 268. North Carolina State University, Raleigh, NC.
- Bowen, W. R. 1980. *Turfgrass Pests*. Cooperative Extension Division of Agricultural Sciences Publication No. 4053. University of California, Berkeley, CA.
- Bruneau, Arthur H. 1984. *Turfgrass Pest Management – A Guide to Major Turfgrass Pests and Turfgrass*. North Carolina Agriculture Extension Service AG No. 348. North Carolina State University, Raleigh, NC.
- Color Atlas of Turfgrass Weeds*. Ann Arbor Press, 310 North Main Street, P. O. Box 320, Chelsea MI 48118.
- Converse, Jim. 1974. *ProTurf Guide to the Identification of Grasses*. The O. M. Scott & Sons Company, Marysville, OH.
- Converse, Jim. 1974. *ProTurf Guide to the Identification of Dicot Turf Weeds*. The O. M. Scott & Sons Company, Marysville, OH.
- Cooperative Extension Staff. 1988. *OSU Extension Agent's Handbook of Insect, Plant Disease, and Weed Control*. Division of Agriculture Cooperative Extension Service Circular E-832. Oklahoma State University, Stillwater, OK.
- Dunn, G. A., and M. K. Kennedy. 1983. How to Prepare Turf Insects for Identification. *American Lawn Applicators*, Jan./Feb., 18-21.
- Frankie, G. W., H. A. Turney, and P. J. Hamman. 1973. *White Grubs in Texas Turfgrass*. Texas Agriculture Extension Service L-1131. Texas A&M University, College Station, TX.
- Green, R. L., R. V. Sturgeon, Jr., Ken Pinkston, O. Norman Nesheim, and G. W. Cuperus. 1985. *Turf Maintenance Calendar for Bermudagrass*. Division of Agriculture Cooperative Extension Service Circular E-842. Oklahoma State University, Stillwater, OK.
- Green, R. L., R. V. Sturgeon, Jr., Ken Pinkston, O. Norman Nesheim, and G. W. Cuperus. 1985. *Maintenance Calendar for Bentgrass Putting Greens*. Division of Agriculture Cooperative Extension Service Circular E-843. Oklahoma State University, Stillwater, OK.
- Hawthorne, D. W. 1983. Other Mammals: Armadillos, pp. D53-D61. In R. M. Timm (ed.), *Prevention and Control of Wildlife Damage*. Great Plains Agriculture Council and University of Nebraska Cooperative Extension Service. Institute of Agricultural and Natural Resources, Lincoln, NE.
- Henderson, F. R. 1983. Other Mammals: Moles, pp. D53-D61. In R. M. Timm (ed.), *Prevention and Control of Wildlife Damage*. Great Plains Agriculture Council and University of Nebraska Cooperative Extension Service. Institute of Agricultural and Natural Resources, Lincoln, NE.
- Johnson, W. T., and H. H. Lyon. 1976. *Insects That Feed on Trees and Shrubs*. Cornell University Press, Ithaca, NY.
- Knight, J. E. 1983. Carnivores (Meat-Eating Mammals): Skunks, pp. C81-C86. In R. M. Timm (ed.), *Prevention and Control of Wildlife Damage*. Great Plains Agriculture Council and University of Nebraska Cooperative Extension Service. Institute of Agricultural and Natural Resources, Lincoln, NE.
- Leuthold, Larry. 1987. *Lawn Weed Control*. Cooperative Extension Service Circular No. 685. Kansas State University, Manhattan, KS.
- Metcalf, C. L., W. P. Flint, and R. L. Metcalf. 1962. *Destructive and Useful Insects: Their Habits and Control*. 4th ed. McGraw-Hill, New York, NY.
- MP 169, *Weeds of Arkansas Lawns, Turf, Roadsides and Recreation Areas*. Business Office, Cooperative Extension Service, University of Arkansas, P. O. Box 391, Little Rock, AR 72203. \$5 per copy – make check payable to University of Arkansas Cooperative Extension Service.

- Nesheim, O, Norman. 1984. *Ornamental and Turf Pesticide Applicator Manual*. Division of Agriculture Cooperative Extension Service Circular E-838. Oklahoma State University, Stillwater, OK.
- Nesheim, O. Norman. 1984. *Applying Pesticides Correctly – A Guide for Commercial/ Noncommercial Applicators*. Division of Agriculture Cooperative Extension Service Circular E-834. Oklahoma State University, Stillwater, OK.
- Niemczyk, H. D. 1977. Thatch: A Barrier to Control of Soil Inhabiting Insect Pests of Turf. *Weeds, Trees, and Turf*, Feb.: 16-19.
- Scotts. 1979. *Information Manual for Lawns*. The O. M. Scott & Sons Company, Marysville, OH.
- Short, D. E., and J. A. Reinert. 1979. *Lawn Insects and Their Control*. Florida Cooperative Extension Service Circular No. 427. University of Florida, Gainesville, FL.
- Smiley, Richard W. 1983. *Compendium of Turfgrass Diseases*. Department of Plant Pathology, Cornell University. The American Phytopathological Society, St. Paul, MN.
- SP 79, *Weeds of Southern Turfgrass*. Publications, P. O. Box 110011, University of Florida, Gainesville, FL 32611-0011. \$8 per copy – make check payable to the University of Florida.
- Tashiro, H. 1987. *Turfgrass Insects of the United States and Canada*. Cornell University Press, Ithaca, NY.
- Weed Identification Guide*. Southern Weed Science Society, 1508 W. University Avenue, Champaign, IL 61821. \$97 (Includes over 300 high-quality color photos).
- Weeds of the Northeast*. Comstock Publishing Associates, Cornell University Press, Sage House, 512 East State Street, Ithaca, NY 14850.

# Turfgrass Glossary

**Abdomen:** The third or most posterior of the three major body divisions of an insect.

**Absorption:** The process by which an herbicide passes from one system into another, e.g., from the soil solution into a plant root cell or from the leaf surface into the leaf cells.

**Acid equivalent (ae):** The theoretical yield of parent acid from a pesticide active ingredient, which has been formulated as a derivative. For example, Roundup Pro contains 4 pounds per gallon of the isopropylamine salt form of glyphosate but 3 pounds per gallon of the parent acid.

**Acid soil:** Soil with a pH value less than 7.0.

**Activation:** The process by which a surface applied herbicide is moved into the soil where it can be absorbed by emerging seedlings. This is normally accomplished by rainfall, irrigation or tillage. Activation does not imply any chemical change in the active ingredient.

**Active ingredient (a.i.):** The chemical in an herbicide formulation primarily responsible for its phytotoxicity and which is identified as the active ingredient on the product label.

**Adjuvant:** Any substance in an herbicide formulation or added to the spray tank to modify herbicidal activity or application characteristics.

**Adsorption:** The process by which an herbicide associates with a surface, e.g., a soil colloidal surface.

**Aestivate:** To spend the summer in a dormant condition; opposed to hibernate.

**Alate:** Winged.

**Alkaline soil:** Soil with a pH greater than 7.0.

**Allelopathy:** The adverse effect on the growth of plants or microorganisms caused by the action of chemicals produced by other living or decaying plants.

**Antagonism:** An interaction of two or more chemicals such that the effect when combined is less than the predicted effect based on the activity of each chemical applied separately.

**Antennae:** In larval and adult stages of an insect, paired segmented appendages, on each side of the head, functioning as sense organs.

**Anterior:** Toward the front (head), as opposed to posterior.

**Antibiosis:** Plant characteristics that affect insects in a negative manner (such as increased mortality or reduced fecundity); a type of plant resistance to insects.

**Apical:** At, near, or pertaining to the tip or apex.

**Apices:** At or near the apex or “top” of a structure.

**Arthropods:** Invertebrate animals with jointed appendages; members of the phylum Arthropoda.

**Band treatment:** Applied to a linear restricted strip on or along crop rows rather than continuous over the field area.

**Beneficial:** A useful insect, often one that is a predator or parasitoid of a harmful insect.

**Bioassay:** Quantitative or qualitative determination of herbicide by use of sensitive indicator plants or other biological organisms.

**Biological control of weeds:** Control or suppression of weeds by the action of one or more organisms, through natural means, or by manipulation of the weed, organism or environment.

**Biological control:** Using any biological agent (often an insect) to control a pest.

**Biotype:** A population within a species that has a distinct genetic variation.

**Bivoltine:** Two generations per year.

**Boot or Booting:** A growth stage of grasses (including cereal crops) when the upper leaf sheath swells due to the growth of the developing spike or panicle.

**Brachypterous:** Having short wings not covering the abdomen.

**Broadcast treatment:** Applied as a continuous sheet over the entire field.

**Broods:** A group or cohort of offspring produced by a parent or parent population at different times or in different places.

**Callow adult:** A recently molted, soft-bodied, pale adult.

**Carrier:** A gas, liquid, or solid substance used to dilute or suspend an herbicide during its application.

**Caterpillar:** The larva of a moth, butterfly, skipper or sawfly.

**Cephalothorax:** The combined head and thorax of spiders and other arachnids.

**Cerci:** A pair of appendages at the tip of the abdomen.

**Chemical name:** The systematic Name of a chemical compound according to the rules of nomenclature of the International Union of Pure and Applied Chemistry (IUPAC), Chemical Abstracts Service or other organization.

**Chitin:** A colorless, nitrogenous polysaccharide secreted by the epidermis and applied to the hardened parts of an insect body.

**Chlorophyll:** The green, light-sensitive pigment of plants that in sunlight is capable of combining carbon dioxide and water to make carbohydrates.

**Chlorosis:** Yellowing of normally green tissue due to chlorophyll destruction or failure of chlorophyll formation.

**Chlorotic:** Having a fading of green color in plant leaves to light green or yellow.

**Chorion:** The outer covering of an insect egg.

**Cocoon:** The silken or fibrous case spun by a larva for protection during its pupal period.

**Common name:** A generic name for a chemical compound. Glyphosate is the common name for Roundup.

**Compatibility:** The characteristic of a substance, especially a pesticide, of being mixable in a formulation or in the spray tank for application in the same carrier without undesirably altering the characteristics or effects of the individual components.

**Competition:** The active acquisition of limited resources by an organism, which results in a reduced supply and consequently reduced growth of other organisms in a common environment.

**Concentration:** For herbicides, the quantity of active ingredient or parent compound equivalent expressed as weight per unit volume (such as pounds per gallon for liquids). Dry herbicide concentrations are expressed as percent by weight.

**Contact herbicide:** An herbicide that causes injury to only the plant tissue to which it is applied, or an herbicide that is not appreciably translocated within plants.

**Cool-season grass:** A cold-tolerant grass with an optimum temperature range of 60-75 degrees F. (15.5-24 degrees C.).

**Costal margin:** The front edge of a wing.

**Crochets:** Hooked spines on the underside of prolegs of caterpillars.

**Culm:** The stem of a grass plant.

**Cultivar:** Cultivated variety.

**Cultural control:** Manipulation of a crop environment to reduce pest increase and damage.

**Cuticle:** The outer covering of an insect formed by a layer of chitin.

**Cyst:** A sac or vesicle.

**Degree-day:** An accumulation of degrees above some threshold temperature for a 24-hour measure of physiological time for cold-blooded organisms, like insects. Degree-days can be expressed in Fahrenheit (FDD) or Celsius (CDD).

**Developmental threshold:** The minimum temperature required for development.

**Diapause:** Physiological state of arrested metabolism, growth and development that may occur at any stage in the life cycle.

**Dicot:** Abbreviated term for dicotyledon; preferred in scientific literature over broad leaf to describe plants.

**Dicotyledon (dicot):** A member of the Dicotyledoneae; one of two classes of angiosperms usually characterized by the having two seed leaves (cotyledons), leaves with net venation and root systems with taproots.

**Diluent:** Any gas, liquid, or solid material used to reduce the concentration of an active ingredient in a formulation.

**Directed application:** Precise application to a specific area or plant organ such as to a row or bed or to the leaves or stems of plants.

**Dispersible granule:** A dry granular formulation that will separate or disperse to form a suspension when added to water.

**Dormancy:** The state of inhibited seed germination or growth of a plant organ when in an environment normally conducive to growth.

**Dormant:** A state of reduced physiological activity.

**Dorsum:** The upper surface, or back.

**Eclosion:** Emergence of the adult insect from the pupa; act of hatching from the egg.

**Economic injury level (EIL):** The number of insects (amount of injury) that will cause losses equal to insect management cost.

**Economic threshold (ET):** The pest density at which management action should be taken to prevent an increasing pest population from reaching the economic injury level.

**Ecosystem:** A living community and its nonliving environment.

**Ecotype:** A population within a species that has developed a distinct morphological or physiological characteristic (e.g., herbicide resistance) in response to a specific environment and that persists when individuals are moved to a different environment.

**Elytra (sing., elytron):** The two thickened, hardened forewings of beetles.

**Emergence:** The event in seedling establishment when a shoot becomes visible by pushing through the soil surface.

**Emulsifiable concentrate (EC):** A single-phase liquid formulation that forms an emulsion when added to water.

**Encapsulated formulation:** Herbicide enclosed in capsule or beads of material to control the rate of release of active ingredient and thereby extend the period of activity.

**Endoparasite:** Parasitic organism living inside its host.

**Entomophagous:** Insect-eating.

**Epinasty:** That state in which more rapid growth on the upper part of a plant organ or part (especially leaf) causes it to bend downward.

**Exoskeleton:** The outside skeleton of insects.

**Femur (pl., femora):** The thigh; in insects, usually the largest segment of the leg articulated at the proximal end nearest the body to the trochanter and distally to the tibia.

**Flowable:** A two-phase formulation containing solid herbicide suspended in liquid and that forms a suspension when added to water.

**Formulation:** (1) A pesticide preparation supplied by a manufacturer for practical use. (2) The process, carried out by manufacturers, of preparing pesticides for practical use.

**Frass:** Solid larval excrement.

**Generation:** A group of offspring of the same species that develop in approximately the same time frame.



**Granular:** A dry formulation consisting of discrete particles generally  $< 10 \text{ mm}^3$  and designed to be applied without a liquid carrier.

**Gregarious:** Occurring in aggregations.

**Grub:** An insect larva; a term usually with specific reference to larvae of Coleoptera and Hymenoptera.

**Head capsule:** The combined sclerites of the head, forming a hard, compact case.

**Head or Heading:** A growth stage of grasses (including cereal crops) when the spike or panicle is emerging or has emerged from the sheath.

**Hemimetabolous:** Simple, incomplete metamorphosis where larval stages (nymphs) are often similar to adults in appearance and feeding behavior.

**Herbaceous plant:** A vascular plant that does not develop persistent woody tissue aboveground.

**Herbicide resistance:** The trait or quality of a population of plants within a species or plant cells in tissue culture of having a tolerance for a particular herbicide that is substantially greater than the average for the species and that has developed because of selection for naturally occurring tolerance by exposure to the herbicide through several reproductive cycles.

**Herbicide:** A chemical substance or cultured biological organism used to kill or suppress the growth of plants.

**Hibernate:** To pass the winter in a dormant state.

**Hindgut:** The posterior region of the digestive tract, between the midgut and anus.

**Holometabolous:** Having a complete transformation, with egg, larval, pupal, and adult stages distinctly separated.

**Incorporate:** To mix or blend an herbicide into the soil.

**Indigenous:** Native to an area.

**Insectivorous:** Feeding on insects.

**Instar:** The stage between molts or shedding of the exoskeleton.

**Integrated pest management (IPM):** A system of economically and environmentally sound practices to reduce the deleterious impact of pest activities; frequently associated with the use of multiple management tactics (e.g., pesticides, cultural control, host plant resistance and biological control).

**Interference:** For plants; the total adverse effect that plants exert on each other when growing in a common ecosystem. The term includes competition, allelopathy, biotic interference and other detrimental modifications in the community or environment.

**Label:** The directions for using a pesticide approved as a result of the registration process.

**Larva:** A young insect; an immature form called a caterpillar, slug, maggot or grub, depending on the kind of insect.

**Lateral movement:** Movement of an herbicide through soil, generally in a horizontal plane, from the original site of application.

**Leaching:** (1) The removal of materials in solution from the soil. (2) The downward movement of material(s) into a soil profile with soil water (material may or may not be in true solution and may or may not move from soil).

**Life cycle:** The period between egg deposition and attainment of sexual maturity as shown by egg laying.

**Macropterous:** Long- or large-winged.

**Maggot:** The larval stage of a true fly (Diptera).

**Mandibles:** An insect's jaws.

**Maxilla:** The hind or second set of jaws behind the mandibles.

**Metamorphosis:** The process of changes through which an insect passes during its growth from egg to adult.

**Microsporidium:** Any of a group of protozoans some of which are pathogens to insects and other animals.

**Migrant:** An insect that migrates. Commonly, migrations are usually one way (usually northward) and are dependent on wind currents and weather patterns.

**Molt:** To cast off or shed the outer skin and so forth at certain intervals before replacement of the cast-off parts by new growth.

**Monocot:** Abbreviated term for monocotyledon; preferred in scientific literature over grass to describe plants.

**Monocotyledon (monocot):** A member of Monocotyledoneae; one of two classes of angiosperms, usually characterized by the following: one seed leaf (cotyledon), leaves with parallel venation, root systems arising adventitiously and usually diffuse (fibrous).

**Moth:** An adult insect (Lepidoptera) with two pairs of scale-covered wings and variously shaped (but never clubbed) antennae.

**Multivoltine:** Having more than one generation in a year or season.

**Nematode:** Any of a class or phylum of elongated cylindrical worms that are parasitic in animals or plants or are free-living in soil or water.

**Nocturnal:** Active at night.

**Non-selective herbicide:** An herbicide that is generally toxic to all plants treated. Some selective herbicides may become non-selective if used at very high rates.

**Non-target species:** A species not intentionally affected by a pesticide.

**Nymph:** An immature stage in insects with incomplete metamorphosis.

**Overtop application:** A broadcast or banded application applied over the canopy of crops such as by airplane or a raised spray boom of ground equipment.

**Overwinter:** To survive the winter.

**Oviposition:** Egg laying.

**Palidia:** A group of spines, usually in a line, found near the anus of scarab grubs.

**Palp:** A segmented process on an arthropod's mouthpart.

**Parasite:** Any animal that lives in, on or at the expense of another.

**Parasitoid:** An arthropod that parasitizes and kills an arthropod host; parasitic in the immature stages but free-living as an adult.

**Pathogen:** A disease-causing organism.

**Pelleted formulation:** A dry formulation consisting of discrete particles usually larger than 10 cubic millimeters and designed to be applied without a liquid carrier.

**Peripheral:** Relating to the outer margin.

**Persistent herbicide:** A herbicide that, when applied at the recommended rate, will harm susceptible crops planted in normal rotation after harvesting the treated crop, or that interferes with regrowth of native vegetation in non-crop sites for an extended period of time. *See residual herbicides.*

**Pesticide interaction:** The action or influence of one pesticide upon another and the combined effect of the pesticide(s) on the pest(s) or crop system.

**Phenology, phenological:** Temporal and seasonal pattern of life history events in plants and animals.

**Pheromone:** A substance secreted by an animal that influences the behavior of other individuals of the same species.

**Phloem:** The living tissue in plants that functions primarily to transport metabolic compounds from the site of synthesis or storage to the site of use.

**Phytophagous:** Feeding upon plants.

**Phytotoxic:** Injurious or lethal to plants.

**Plant growth regulator:** A substance used for controlling or modifying plant growth processes without severe phytotoxicity.

**Polyphagous:** Eating many kinds of foods.

**Postemergence (POST):** (1) Applied after emergence of the specified weed or crop. (2) Ability to control established weeds.

**Posterior:** Toward the rear, as opposed to anterior.

**Predator:** An animal that preys on another.

**Preemergence (PRE):** (1) Applied to the soil before emergence of the specified weed or crop. (2) Ability to control weeds before or soon after they emerge.

**Preplant application:** Applied before planting or transplanting a crop, either as a foliar application to control existing vegetation or as a soil application.

**Preplant incorporated (PPI):** Applied and blended into the soil before seeding or transplanting, usually by tillage.

**Prepupa:** A transitional stage between the end of the larval period and the pupal period.

**Profile:** An outline as seen from a side view.

**Prolegs:** Fleshy, unsegmented abdominal walking appendages of some insect larvae.

**Pronotum:** The upper or dorsal surface of the prothorax.

**Prothorax:** The first, or anterior, of the three segments of the thorax.

**Pubescence:** Fine hair or setae.

**Pupa:** The resting, inactive stage between the larva and the adult in all insects that undergo complete metamorphosis.

**Raster:** A complex of specifically arranged bare places, hairs and spines on the ventral surface of the last abdominal segment, in front of the anus; found on scarabaeid larvae.

**Rate:** For herbicides, the quantity of active ingredient expressed as weight per unit area of treated surface or per unit volume of the treated environment for aquatic applications.

**Registration:** The process designated by the Federal Insecticide, Fungicide and Rodenticide Act (FIFRA) and carried out by the Environmental Protection Agency (EPA) by which a pesticide is legally approved for use in the U.S.

**Residual herbicide:** An herbicide that persists in the soil and injures or kills germinating weed seedlings for a relatively short period of time after application. *See persistent herbicide.*

**Residue:** That quantity of an herbicide or metabolite remaining in or on the soil, plant parts, animal tissues, whole organisms and surfaces.

**Resistance:** Ability to withstand exposure to a potentially harmful agent without being injured. (There is no general agreement as to the distinction between herbicide tolerance and herbicide resistance in plants.)

**Rhizome:** A jointed underground stem that can produce roots and shoots at each node.

**Rostrum:** A snoutlike projection on an insect's head.

**Safener:** A substance that reduces toxicity of herbicides to crop plants by a physiological mechanism.

**Sclerotized:** Of an insect, hardened in definite areas by formation of substances other than chitin.

**Selective herbicide:** A chemical that is more toxic to some plant species than to others.

**Snout:** The prolongation of the head of weevils at the end of which the mouthparts are located.

**Sod:** Plugs, blocks, squares or strips of turfgrass plus soil that are used for planting.

**Soluble concentrate (SC):** A liquid formulation that forms a solution when added to water.

**Soluble granule (SG):** A dry granular formulation that forms a solution when added to water.

**Soluble powder:** A dry formulation that forms a solution when added to water.

**Solution:** A homogeneous or single-phase mixture of two or more substances.

**Species:** The smallest taxonomic group; a population that has a defined range and can exchange genes.

**Spiracle:** A breathing pore through which air enters the trachea; in insects, located laterally on body segments.

**Spittle:** A frothy fluid secreted by insects; saliva.

**Spot treatment:** An herbicide applied to restricted area(s) of a whole unit; i.e., treatment of spots or patches of weeds within a larger field.

**Spray drift:** Movement of airborne spray from the intended area of application.

**Stage:** An insect's developmental status (e.g., the egg stage).

**Stipe:** A small stalk-like structure associated with the maxilla.

**Stolon:** A jointed, aboveground, creeping stem that can produce roots and shoots at each node and may originate extravagantly from the main stem.

**Stylet:** One of the piercing structures in piercing-sucking mouthparts.

**Subterranean:** Existing under the surface of the earth.

**Surfactant:** A material that improves the emulsifying, dispersing, spreading, wetting or other properties of a liquid by modifying its surface characteristics.

**Susceptibility:** The sensitivity to or degree to which a plant is injured by an herbicide treatment.

**Suspension:** A mixture containing finely divided particles dispersed in a solid, liquid or gas.

**Systemic:** Synonymous with translocated herbicide, but more correctly used to describe the property of insecticides or fungicides that penetrate and disperse throughout a plant.

**Tank-mix combination:** Mixing of two or more pesticides or agricultural chemicals in the spray tank at the time of application.

**Tarsal claw:** The claw, usually paired, found on the end of the last tarsal segment.

**Tarsus (pl., tarsi):** The foot; the distal part of the insect's leg that consists of one to five segments.

**Teneral (callow) period:** The time immediately after adult emergence; the adult is soft-bodied and pale.

**Thatch:** The layer of plant litter from long-term accumulation of dead plant roots, crowns, rhizomes and stolons between the zone of green vegetation and the soil surface.

**Thorax:** The second or intermediate region of the insect's body, bearing two legs and wings and composed of three rings, the pro-, meso- and metathorax.

**Threshold:** A beginning point in physiology; the point at which a stimulus is just strong enough to produce a response.

**Tibia:** In insects, the fourth division of the leg articulated at the proximal end nearest the body to the femur and at the distal end to the tarsus.

**Tiller or Tillering:** A growth stage of grasses when additional shoots are developing from the crown.

**Tolerance:** (1) Ability to continue normal growth or function when exposed to a potentially harmful agent (there is no general agreement as to the distinction between herbicide tolerance and herbicide resistance in plants). (2) The concentration of a pesticide residue that is allowed in or on raw agricultural commodities as established by the Environmental Protection Agency.

**Topdressing:** A light covering of soil spread over an established turf grass.

**Toxicity:** The quality or potential of a substance to cause injury, illness or other undesirable effects.

**Toxicology:** The study of the principles or mechanisms of toxicity.

**Toxin:** A poisonous substance.

**Trade name:** A trademark or other designation by which a commercial product is identified.

**Translocated herbicide:** An herbicide that is moved within the plant. Translocated herbicides may be either phloem mobile or xylem mobile. However, the term frequently is used in a more restrictive sense to refer to herbicides that are applied to the foliage and move downward through the phloem to underground parts.

**Turgidity:** The extent of being distended, swollen or bloated.

**Univoltine:** Having one generation in a year or season.

**Vapor drift:** The movement of pesticides as vapor from the area of application after the spray droplets have landed on the target.

**Vector:** An organism that is the carrier of a disease-producing organism.

**Ventral:** The underside.

**Warm-season grass:** A cold-intolerant grass with an optimum temperature range of 80-95 degrees F (27-35 degrees C).

**Weed:** Any plant that is objectionable or interferes with the activities or welfare of man.

**Weed control:** The process of reducing weed growth and/or infestation to an acceptable level.

**Weed eradication:** The elimination of all vegetative plant parts and viable seeds of a weed from a site.

**Wettable powder (WP):** A finely divided dry formulation that can be readily suspended in water.

**Wetting agent:** (1) a substance that serves to reduce the interfacial tensions and causes spray solutions or suspensions to make better contact with treated surfaces (*see surfactant*). (2) A substance in a wettable powder formulation that causes it to wet readily when added to water.

**White grub:** Whitish, C-shaped larva of insects belonging to the family Scarabaeidae.

**Wing pads:** The undeveloped wings of nymphs of hemimetabolous insects (e.g., Hemiptera), which show behind the thorax as two lateral, flat structures.

**Witches'-broom:** An abnormal brushlike growth of weak, tightly clustered plant shoots.

**Worker:** Among social bees, ants and wasps, a female either incapable of reproduction or capable of laying only unfertilized eggs from which males emerge.

**Xeric:** Adapted to an extremely dry habitat.

**Xylem:** The nonliving tissue in plants that functions primarily to conduct water and mineral nutrients from roots to the shoot.

The pesticide information presented in this publication was current with federal and state regulations at the time of printing. The user is responsible for determining that the intended use is consistent with the label of the product being used. Use pesticides safely. Read and follow label directions. The information given herein is for educational purposes only. Reference to commercial products or trade names is made with the understanding that no discrimination is intended and no endorsement by the Cooperative Extension Service is implied.

Issued in furtherance of Cooperative Extension work, Acts of May 8 and June 30, 1914, in cooperation with the U.S. Department of Agriculture, Director, University of Arkansas Cooperative Extension Service. The Arkansas Cooperative Extension Service offers its programs to all eligible persons regardless of race, color, national origin, religion, gender, age, disability, marital or veteran status, or any other legally protected status, and is an Affirmative Action/Equal Opportunity Employer

AG1159-5-19RV