

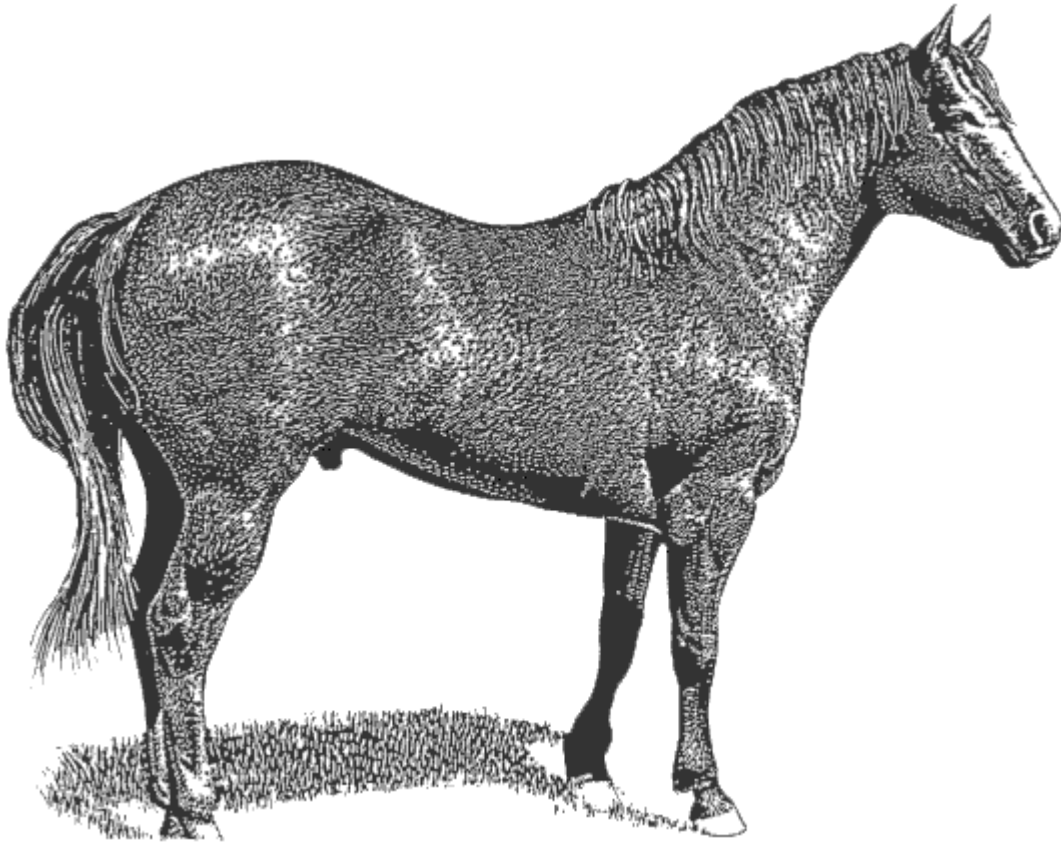

# 2024 ARKANSAS 4-H HORSE PROGRAM

## RULES AND REGULATIONS



The Arkansas Cooperative Extension Service offers its programs to all eligible persons regardless of race, color, national origin, religion, gender, age, disability, marital or veteran status, or any other legally protected status, and is an Affirmative Action/Equal Opportunity Employer.

## OBJECTIVES

The purpose of this activity is to help 4-H members to:

1. Develop leadership, initiative, self-reliance, sportsmanship and other desirable traits of character.
2. Experience the pride and responsibility of owning a horse or pony and receive training in its care, feeding, management and related costs.
3. Appreciate horseback riding as a healthy and wholesome form of recreation.
4. Develop skill in horsemanship, patience and understanding in handling horses and ponies.
5. Gain knowledge of safety precautions to prevent injuries to themselves, others and their mounts.
6. Develop greater love for animals and a humane attitude towards them.
7. Prepare for citizenship responsibilities by working together in groups and supporting community horse projects and activities.

## THE 4-H HORSE PLEDGE

I pledge:

**“My Head to clearer thinking”** – Working with animals provides mental relaxation from schoolroom studies and at the same time stimulates quick thinking and alertness.

**“My Heart to greater loyalty”** – The close bond of comradeship that develops between a horse and his master and between young people planning and working together in a common interest is conducive to a deepening sense of loyalty and consideration for others.

**“My Hands to larger service”** – Skillful hands are a must for a horseman. It is the touch of the hands on the reins which telegraphs the rider’s wish to his mount.

**“My Health to better living”** – Outdoor activities affect every nerve, muscle and organ of the body in a healthful way.

**“For my club, my community, my country, and my world”** – The associations and varied activities in 4-H work provide many opportunities for young people to prepare themselves for active participation in the social and economic life of their community.

## Updated Rules and Highlights for 2024

*MODIFIED RULES ARE NOTED WITH A HIGHLIGHT THROUGHOUT THE BOOK*

1. High Point winners are now eligible to win more than one high point award during the show.

### Fees for 2024 State Show

Class Fee: \$10.00

One time Registration Fee for Horse Show Classes: \$10.00

Goat Fee: \$10/run

Cattle Fee: \$45/run

Stall Fee: \$30.00 per day.

RV Spot Fee: \$35.00 per night

Contest Fee: \$10.00 per individual/per contest.

T-Shirts (optional): \$15.00. *T-Shirts cannot be ordered after the registration deadline.*

Clinics – FREE

***DEADLINE TO ENTER IS JUNE 24<sup>TH</sup>.***

***Checks should be made out to CES.***

#### SOUTHERN REGIONAL 4-H HORSE CHAMPIONSHIP

**If you wish to compete at Southern Regionals, you MUST enter before leaving the State Show. There will be no entries accepted through email or phone.**

**As of 2012, ALL Participants in the Southern Regional Horse Show MUST wear an approved helmet while on a horse (competition or warm-up).**

The **2024** Southern Regional 4-H Horse Championships will be held in Perry, GA **July 31<sup>st</sup> - August 4<sup>th</sup>.**

Each state that participates in the Southern Regional 4-H Horse Championships is allowed 45 horses. To compete at Southern Regionals, a contestant must have competed at the State Show. There are no other qualification requirements. Consideration for entry to regionals will not be given until a completed Southern Regional entry form and appropriate fees are submitted. Please see contest rules pertaining to the qualification system for contestants wishing to participate in any educational contests held at the Southern Regional 4-H Horse Show. All entries for Southern Regionals MUST be completed prior to leaving the State 4-H Show.

# Table of Contents

SCHEDULE.....	5
RULES AND REGULATIONS.....	6
JUDGED PERFORMANCE AND RANCH HORSE DIVISIONS.....	9
HALTER DIVISION.....	75
SPEED DIVISION.....	76
ROPING DIVISION.....	82
EDUCATIONAL CONTESTS.....	86
HORSE JUDGING.....	86
HORSE BOWL.....	87
HIPPOLOGY.....	88
TEAM PRESENTATION.....	90
INDIVIDUAL PRESENTATION.....	92
PUBLIC SPEAKING.....	92



**Arkansas 4-H State Horse Show  
White County Fairgrounds Searcy, AR  
July 9-11, 2024**

**DEADLINE TO ENTER IS JUNE 24<sup>TH</sup> – T-shirts cannot be ordered after this date.**

**Monday, July 8th**  
12:00 p.m. Horses can begin to arrive on grounds

**Tuesday, July 9th**  
8:45 a.m. Pony Height Check (Back of Arena)

9:00 a.m. Class 1 Junior Goat Tying  
Class 2 Senior Goat Tying  
Class 3 Pony Barrel Racing (exhibitors 9-12 years old)  
Class 4 Junior Barrel Racing  
Class 5 Senior Barrel Racing  
**Parent and Leader Barrel Racing**  
Class 6 Pony Pole Bending (exhibitors 9-12 years old)  
Class 7 Junior Pole Bending  
Class 8 Senior Pole Bending  
**Parent and Leader Pole Bending**  
\*\*\*\*\* Break – 30 mins\*\*\*\*\*  
Class 9 Pony Flag Race (exhibitors 9-12 years old)  
Class 10 Junior Flags  
Class 11 Senior Flags  
Class 12 Junior Keyhole  
Class 13 Senior Keyhole  
Class 14 Junior Stake Race  
Class 15 Senior Stake Race  
\*\*\*Break for Ranch Set Up\*\*\*  
Class 16 Ranch Roping  
Class 17 Ranch Boxing

**Wednesday, July 10th**  
8:00 a.m. Class 18 Stock Type Mares  
Class 19 Stock Type Geldings  
Class 20 Ranch Halter (mares and geldings)  
Class 21 Ponies and Miniature Halter  
Class 22 Junior Showmanship  
Class 23 Senior Showmanship  
\*\*\*\*\* Break - Arena Open for 30 mins\*\*\*\*\*  
Class 24 Hunter Under Saddle  
Class 25 Hunt Seat Equitation

\*\*\*\*\* Break – Arena Open for 30 mins\*\*\*\*\*  
Class 26 Pony Pleasure (exhibitors 9-12 years old)  
Class 27 Junior Western Pleasure  
Class 28 Senior Western Pleasure  
**Parent and Leader Western Pleasure**  
Class 29 Junior Western Horsemanship  
Class 30 Senior Western Horsemanship  
Class 31 Western Riding  
Class 32 Reining  
Class 33 Junior Trail  
Class 34 Senior Trail  
Class 35 Junior Ranch Trail  
Class 36 Senior Ranch Trail  
\*\*20 min. Break – Ranch Set up and warm up\*\*  
Class 37 Junior Ranch Rail  
Class 38 Senior Ranch Rail  
Class 39 Junior Ranch Riding  
Class 40 Senior Ranch Riding  
Class 41 Ranch Reining

**All Day** Tack and Clothes Swap (Arena – near concession Stand.)

**Thursday, July 11th**  
**Education Building**  
8:30 a.m. Public Speaking  
Individual Demonstration  
Team Demonstration  
9:15 a.m. Hippology Contest Check-in  
9:30 a.m. Hippology Contest Begins  
2:00 p.m. Horse Bowl  
Horse Bowl and Hippology Awards to immediately follow the Horse Bowl Contest

## RULES AND REGULATIONS

### 1. *Project Requirements.*

- a. Be a bona fide 4-H member enrolled in a horse project in Arkansas.
- b. Follow directions of adult 4-H leaders and extension agents.
- c. Participate in activities and events related to the project.

### 2. *Participation.*

- a. **All 4-H Horse Show participants must have passed their 9<sup>th</sup> birthday prior to January 1, 2024. Senior 4-H members must be 14 years old by January 1<sup>st</sup> and may remain eligible for 4-H programs until December 31 of the year they celebrate their 19<sup>th</sup> birthday.**
- b. Members can show an unlimited number of horses. Members can enter more than one horse in any the following classes: Trail, western riding, reining, all speed classes, breakaway roping, tie-down roping, team roping, goat tying, ranch trail, ranch riding, ranch reining, ranch boxing, ranch roping and all dressage classes. All other classes, members may only enter one horse. The same horse may only be shown once in a class, unless shown by siblings. Siblings may share a horse, even if in the same age division in the above listed classes.
- c. Stallions will not be allowed.
- d. Ponies must be measured at 52 inches or less.
- e. Classes denoted as Junior and Senior pertains to the rider and not the horse.
- f. Only authorized persons will be allowed in the ring at the time of judging.
- g. All pony riding classes are for riders 9-12 years old. Pony and miniature halter have no age limit.

### 3. *Classes.*

- a. There are 41 classes within seven qualifying divisions (listed below in table).
- b. All regional/district horse shows should offer at least one class in the following qualifying divisions. To be eligible for the state 4-H show, an exhibitor *must* have shown at a regional/district show. Once an exhibitor shows in a class at a regional show within a division, they are eligible to enter in any class in that select division at the state show. For example, once a participant enters the hunter under saddle at the regional show, that participant will become eligible to show in all hunter division classes at state.

### 4. *High Point Awards.*

- a. High-point awards will be awarded in the judged performance division, speed events division, ranch division and roping division if sponsorships are available and acquired. Only those classes within that division will count towards that division. First place in a class will receive 10 points, second place will receive 9, and so on to the tenth placing.
- b. There will be one award for the Junior division and one award for the Senior division. Pony classes **DO NOT** count for Junior High Point. A separate Pony High Point is awarded for the most points accumulated on a single pony for the entirety of the state show. The points are tabulated on a one horse/one rider combination.
- c. Tie breakers for all division high points will be number of 1<sup>st</sup> places, 2<sup>nd</sup> places, 3<sup>rd</sup> places, etc.
  - i. If there is still a tie, in the speed division, the pole bending class will serve as tie breaker, followed by barrel racing.
  - ii. Trail will serve as tie breaker for the judged performance division, followed by western riding then western pleasure.
  - iii. Boxing will serve as tie breaker for the ranch horse division, followed by ranch riding.
  - iv. For the roping division, girl's high point/all-around tie breaker will be breakaway, then goat tying, and then team roping. If the contestants are still tied, the tie breaker will be on money won. For the boy's high point/all-around the tie breakers will be tie down, then breakaway, and then team roping. If the contestants are still tied, the tie breaker will be on money won.

<i>Halter Division</i>	<i>Judged Performance Division</i>	<i>Speed Events Division</i>	<i>Roping Division</i>	<i>Ranch Horse Division</i>
Pony and Miniatures	Trail	Barrel Racing	Breakaway	Ranch Halter
Stock Type Mares	Western Riding	Pole Bending	Tie-Down Calf Roping	Ranch Trail
Stock Type Geldings	Western Pleasure	Stake Race	Team Roping	Ranch Riding
	Horsemanship	Flag Race	Goat Tying	Ranch Roping
	Reining	Keyhole Race		Ranch Reining
	Showmanship			Ranch Boxing
	Hunter under Saddle			
	Hunt Seat Equitation			

**5. Class cancellation.**

- a. The show committee reserves the rights to cancel, combine or divide any class or classes. Large classes may be divided for workout at the discretion of judge and/or horse committee.
- b. If a class is cancelled at the regional show due to lack of entries, the 4-H'er will remain eligible to enter that class at the state horse show. If the regional show does not offer a class within a particular division, the participant will be allowed automatic entry into the state show in that division.
- c. Beginning after the 2014 show, classes that have less than 5 entries will be combined into an all-age class the following year. Example: Junior Western Riding and Senior Western Riding. If for 3 consecutive following years, the combined age group class stays below 5, it will be eliminated. However, if the class grows to have at least 5 juniors and 5 seniors for two consecutive years, it will be split into junior and senior once again. Final decision for elimination of classes will be up to the state horse show committee.

**6. Appeals.**

- a. The judge's decision as to placing is final. An appeal to the 4-H horse show committee is justified only if there appears to be an error in the conduct or composition of the class. If doubt persists, the decision of the 4-H horse show committee is final. An official protest must be in writing and accompanied by a \$50 remittance (cash only) by the end of the next scheduled event.

**7. Liability and Insurance.**

- a. Neither the show nor sponsors will be responsible for any accident or injury to the person or property of any exhibitor, spectator, attendant, or other people. Any injuries to 4-H members should be reported immediately to the 4-H horse show committee. Accidents or injury to members or rider should be filed by written note indicating type of injury, name, and address to the 4-H horse show committee.
- b. 4-H members will be covered with health and accident insurance from the time they leave their homes until they return to their homes. While riding, insurance limits are restricted to \$1,000 maximum.

**8. Exercising and riding of horses.**

- a. Should be done in designated arenas and warm-up arenas should be done only by a 4-H member or a member's parent or club volunteer/leader.
- b. Handling of horses can only be done by 4-H members, parents, immediate family members or certified 4-H leaders.
- c. There should be no riding bareback or double anytime during the show or on the grounds.

**9. Abuse or Abusive Equipment Rule, Unsportsmanlike Conduct.**

- a. The judge or designated show officials have the authority to require the removal or alteration of any piece of equipment which, in his/their opinion is unsafe, tends to give unfair advantage or is deemed inhumane. Inhumane treatment of a horse identified by the host show committee at any time during the state 4-H horse show on any location on the show grounds may result in disqualification, dismissal and suspension from

further participation in the state 4-H horse show classes, subject to approval of the state 4-H horse show committee.

- b. Any horse receiving inhumane treatment while exhibiting may be dismissed upon the discretion of the judge or show official appointed by the state 4-H horse show manager. The standard by which conduct, or treatment will be measured is what the show management committee rules a reasonable person, informed, and experienced in generally accepted equine training and exhibition procedures, would determine to be cruel, abusive or inhumane.
- c. When an exhibitor or exhibitor's parent, guardian, certified 4-H leader, or agent is guilty of unsportsmanlike conduct or misbehavior during the show, the 4-H horse show committee may suspend such exhibitor's right to participate in future classes and/or shows as deemed appropriate. This may include the removal of the guilty party from the show grounds. All people attending the horse must show sportsmanship throughout the show. Horses must be kept under control. Cruelty to or rough handling of horses will not be allowed at any time during the show or on the show grounds and may result in disqualification.

**10. Lameness.**

- a. The judge shall examine and check for lameness of all horses brought into any class. The judge has the authority to excuse any horse from the class, due to lameness, at any time while being judged. This is essential regardless of whether or not the competition indicates it is necessary.
  - i. Obvious lameness shall be cause for disqualification. Obvious lameness is:
    - 1. Consistently observable at a trot under all circumstances.
    - 2. Lameness is obvious at a walk.
    - 3. Minimal weight-bearing in motion and/or at rest and inability to move.

**11. Health/Coggins.**

- a. Horses for the show must be healthy and sound. A negative equine infectious anemia (Coggins) test conducted within 12 months of the show will be required for all horses entered in the state 4-H horse show.

**12. Governing Rulebooks.**

- a. The National High School Rodeo Handbook will be used for roping, barrel racing, pole bending and goat tying rules not specifically covered in the Arkansas 4-H Horse Show Rules and Regulations. The American Quarter Horse Association Handbook will be used for rules not specifically covered in the Arkansas 4-H Horse Show Rules and Regulations in all other classes.

**13. Tack and Equipment.**

- a. An official of the show may check the appointments as each horse enters the judging area. However, it is the exhibitor's responsibility to be aware of all rules and enter the arena with the proper tack and attire. Official judges may request removal or alteration of any equipment deemed inappropriate.
- b. Numbers must be worn so that they are visible to judge, ring steward or other show officials.

**14. Entries.**

- a. If funds to make up for an insufficient check are not collected by the first day of the show, the participant will not be eligible to compete in the regional or state 4-H horse show. There will also be a \$25 fee assessed for insufficient funds.
- b. There will be ABSOLUTELY no entries made at the state horse show. All entries are taken through 4-H online.
- c. Substitutions of another rider during a class will not be permitted.

**15. Refunds.**

- a. There will be no refunds given at the show. Exception: Veterinarian letter of illness or physician letter of illness.

**16. Staying overnight with horses.**

- a. All exhibitors that are staying overnight with horses, must have a stall for each horse. There will be no tying to trailers overnight.

**17. Gate Calls.**

- a. Contestants for all classes will have 60 seconds to enter the arena. If the contestant doesn't enter the arena within 60 seconds, they will be disqualified.

**18. Rule Changes.**



- a. If there is a proposal to change the location of a state qualifying show, state show, or state roping, it must be submitted to the State Extension office by October 1st to be eligible for review of the following year. Further, it must be signed by your county extension agent and can be in paper or electronic form.

## **JUDGED PERFORMANCE AND RANCH HORSE DIVISION**

### ***General Equipment Rules***

1. When exhibitor equipment failure causes a delay or a run to be discontinued, the judge will disqualify the entry.
2. In any approved class, the judge shall have the authority to require the removal or alteration of any piece of equipment or accoutrement which is unsafe, or in his opinion, would tend to give a horse an unfair advantage or which he believes to be inhumane.
3. Tails may be lengthened by hair to hair attachment only with no attachments of any kind to the tailbone.
4. The use of weighted tails is acceptable.
5. The use of earplugs or cotton in the horse's ears is acceptable.
6. Reruns will not be allowed in instances of equipment failure.
7. Failure by exhibitor to wear correct number(s) in a visible manner shall result in disqualification. It is recommended the visible numbers be on both sides of the horse when showing in the under saddle classes.

### ***Western Classes***

#### **Western Equipment**

1. Hackamore means the use of a flexible, braided rawhide, leather or rope bosal, the core of which must be flexible. A hackamore must use a complete mecate rein, which must include a tie-rein. Absolutely no rigid material will be permitted under the jaws, regardless of how padded or covered. Horse hair bosals are prohibited. This rule does not refer to a mechanical hackamore.
2. Snaffle bits in western performance classes mean the conventional O-ring, egg-butt or D-ring with a ring no larger than 4" in diameter (100 mm). The inside circumference of the ring must be free of rein, curb or headstall attachments which would provide leverage. The mouthpiece should be round, oval or egg-shaped, smooth and unwrapped metal. It may be inlaid, but smooth or latex-wrapped. The bars must be a minimum of 5/16" (8 mm) in diameter, measured one inch (25 mm) in from the cheek with a gradual decrease to center of the snaffle. The mouthpiece may be two or three pieces. A three-piece, connecting ring of 1 1/4" (32 mm) or less in diameter, or a connecting flat bar of 3/8" to 3/4" (10 mm to 20 mm) measured top to bottom, with a maximum length of 2" (50 mm), which lies flat in the horse's mouth, is acceptable. Optional leather strap attached below the reins on a snaffle bit is acceptable.
3. Bit in western performance classes means the use of a curb bit that has a solid or broken mouthpiece, has shanks and acts with leverage. All curb bits must be free of mechanical device and should be considered a standard western bit.
4. The description of a legal, standard western bit includes:
  - a. 8 1/2" (215 mm) maximum length shank to be measured as indicated in the diagram on the previous page. Shanks may be fixed or loose.
  - b. concerning mouthpieces, bars must be round, oval or egg shaped, smooth and unwrapped metal of 5/16" to 3/4" (8 mm to 20 mm) in diameter, measured 1" (25 mm) from the cheek. However, wire on the sway bars (above the bars and attaching to the spade) of a traditional spade bit is acceptable. They may be inlaid, but must be smooth or latex wrapped. Nothing may protrude below the mouthpiece (bar), such as extensions or prongs, including upward prongs on solid mouthpieces. The mouthpiece may be two or three pieces. A three-piece, connecting ring of 1 1/4" (32 mm) or less in diameter, or a connecting flat bar of 3/8" to 3/4" (10 mm to 20 mm) measured top to bottom with a maximum length of 2" (50 mm), which lies flat in the horse's mouth, is acceptable.
  - c. The port must be no higher than 3 1/2" (90 mm) maximum, with rollers and covers acceptable. Broken mouthpieces, halfbreeds and spades are standard.
  - d. Donut and flat polo mouthpieces are not acceptable.
  - e. A curb bit must be used with a curb strap or curb chain properly attached so as to make contact with horse's chin.
  - f. Slip or gag bits are permitted in speed events.
5. Except for hackamore /snaffle bit classes or junior horses shown with hackamore/snaffle bit, only one hand may be used on the reins, and the hand must not be changed. The hand is to be around the reins: index finger only between

split reins is permitted. In trail, it is permissible to change hands to work an obstacle. Violation of this rule is an automatic disqualification.

- a. Any horse of any age may be shown one or two handed with a snaffle bit/hackamore.
6. Romal means an extension of braided or round material attached to closed reins. This extension shall be carried in the free hand with a 16-inch (40 cm) spacing between the reining hand and the free hand holding the romal. When using romal reins, the rider's hand shall be around the reins with the wrists kept straight and relaxed, the thumb on top and the fingers closed lightly around the reins. When using a romal, no fingers between the reins are allowed. The free hand may not be used to adjust the rider's length of rein in any reining class. During reining, the use of the free hand while holding the romal to alter the tension or length of the reins from the bridle to the reining hand is considered to be the use of two hands and a score of 0 will be applied, with the exception of any place a horse is allowed to be completely stopped during a pattern. In all other classes, including the reined portion of working cow horse, boxing, VRH ranch reining, VRH ranch cow work, VRH limited ranch cow work and all RHC working ranch horse classes, the free hand may be used to adjust the rider's length of rein. In all western classes, excess rein(s) may be straightened or disentangled anytime during the class, provided the rider's free hand used to straighten or disentangle remains behind the rein hand. Any attempt to alter tension or length of the reins from bridle to rein hand is to be considered use of two hands and a penalty score of zero or disqualification will be applied.
  - a. The romal shall not be used forward of the cinch or to signal or cue the horse in any way. Any infraction of this rule shall be penalized severely by the judge.
7. Horses that are shown with a hackamore or snaffle bit may be ridden with one or two hands on the reins. The tails of the reins must be crossed on the opposite side of the neck when riding with two hands on split reins except boxing, reining, and versatility ranch horse classes. Closed reins (example mecate) may not be used with a snaffle bit, except in versatility ranch horse classes, ranch riding, where a mecate is permitted. When using a snaffle bit in working cow horse, boxing, ranch riding, ranch trail, all VRH classes and all RHC classes, a leather or other woven material chip strap of any width is to be used and should be attached to the bit below the reins. No iron, chain, or other material is allowed. The chin strap is allowed to include metal buckles and/or keepers.
  - a. In all western classes, horses will be shown in a western saddle and appropriate bridle, snaffle bit or hackamore for the duration of the class. A western saddle is a common type of saddle distinguished by a large noticeable fork on which there is some form of horn, a high cantle and large skirts. Silver equipment will not count over a good working outfit. Split reins or romal reins must be used on a curb bit except speed events, team penning, ranch sorting, roping and cowboy mounted shooting where they are optional. When a curb bit is used, a curb strap or curb chain is required, but must meet the approval of the judge, be at least one-half inch in width and lie flat against the jaw of the horse. Curb chains cannot be tied to the bit with string or cord. A broken strap or chain is not necessarily cause for disqualification.

#### **Speed Event and Roping Equipment**

1. In roping and speed events, western - type equipment must be used. Use of rawhide or mechanical hackamores or other type of bridles is the optional choice of the contestant. However, mechanical hackamore nosepieces must be covered in leather and cannot have visible or bare metal in contact with the horse's head. The judge or steward may prohibit the use of any bit or equipment they consider inhumane or would tend to give a horse/rider an unfair advantage.
2. Tie-downs, used for roping and speed events must be leather, flat nylon or rope a minimum of 3/8 inch in diameter.
3. Bonnets (tie-down that goes over the poll and/ or across the forehead) made of rope, flat nylon webbing or leather only (minimum 3/8 inch diameter) are permitted.
4. Martingales and draw reins are permitted for speed events. However, martingales used with curb bits must have rein stops. Draw reins may not be attached between or around the front legs.

#### **Western: Optional Equipment**

1. Rope or riata; if used, the rope or riata must be coiled and attached to the saddle.
2. Hobbles attached to saddle.
3. Tapaderos, except in working cow horse where they are not allowed.
4. Protective boots, leg wraps and bandages are allowed in reining, boxing, barrel racing, pole bending, stake racing, tie-down roping, breakaway roping, team roping, western horsemanship, and ranch horse classes. The use of slip on (easy care) horse boots or related footwear are not considered as protective boots and are permissible to be worn in all classes.
5. Spurs; not to be used forward of the cinch.

#### **Western: Prohibited Equipment**

1. Protective boots, leg wraps and bandages are prohibited in western pleasure, trail, halter, western riding and showmanship.

2. Wire curb straps, regardless of how padded or covered, or curb strap with tacks/rivets.
3. Any curb strap narrower than one-half inch.
4. Chain, wire, or metal tie-down or bonnets are prohibited, regardless of how padded or wrapped.
5. Belly Bands, saw tooth bits; hock hobbles; tack collars; tack curb straps or tack hackamores; whips used for showmanship; war bridles or like devices; riding in a curb bit without a curb strap; wire or solid metal curb straps no matter how padded; wire cavesson; wire or cable tie-downs; bumper bits; metal bosals (no matter how padded); chambons; headstalls made of metal (no matter how wrapped or padded), twisted rawhide, or rope may not be used on a horse's head (3/8 inch rope may be used with a slip/gag bit or a bonnet); running martingales used with curb bits used without rein stops; draw reins attached between or around the front legs will not be allowed at AQHA-approved events.
6. Tack collars for roping.
7. Tie-downs may not have a built in cavesson or noseband. Cavesson or noseband of any kind may not be used during competition.
8. Fenders may not be connected by string or any other material.

### **Western Attire**

In halter, speed events, roping, goat tying, and other western classes it is mandatory to wear appropriate Western attire, including long sleeves, pants, and collared shirt (band, standup, tuxedo, etc.). Shirt sleeves may not be rolled up, and shirts must be tucked inside pants when the horse enters the arena for his/her class. Coats, vest, ties, etc. are optional. Spurs, chaps or similar equipment are optional. Ball caps are not acceptable. A Western (cowboy) hat is required, with the exception of speed events. Special exceptions may be made for religious reasons or physical handicap, but must be requested by filing a written request to Arkansas 4-H State Horse Show and obtaining written approval prior to participation. The hat must be on the rider's head when the exhibitor enters the arena. No sweatshirts or T-shirts allowed. Western boots must be worn, and sneaker type "sport shoes" are not acceptable. The dress code must be followed by all participants!

Exhibitors may wear safety headgear (helmet) in any class without judge discrimination. As of 2010, all riders are **required** to wear properly fitted equestrian headgear with fastened chin harness (ASTM/SEI approved helmets) in all speed event classes (barrels, poles, stake and flag races). In classes requiring helmets, the helmet must remain securely fastened on the exhibitor's head the entire time the exhibitor is in the arena. If the helmet falls off or is taken off prior to leaving the arena, the exhibitor will be disqualified. Exhibitors may not be tied, buckled or fastened in the saddle in any manner by any means during competition, with the exception of rubber bands in the speed events.

# WESTERN BITS

## An Example of Legal Bit

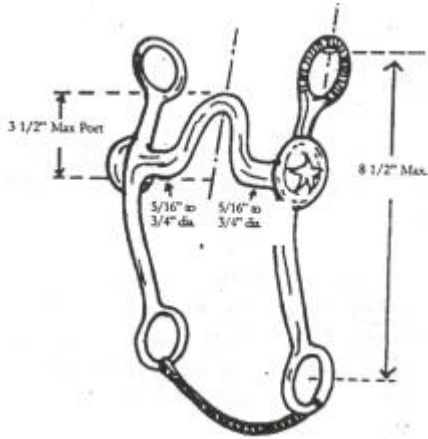

## Some Examples of Illegal Bits

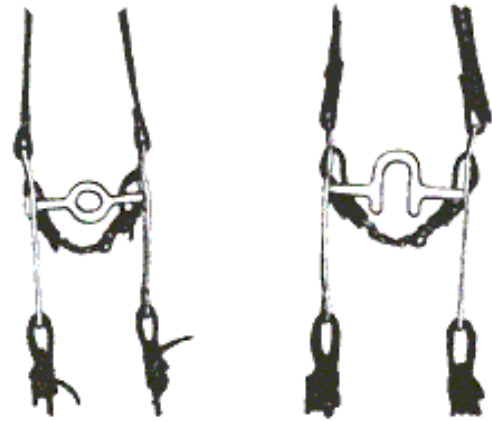

Donut Bit  
Doughnut Bit

Prong Bit

## Typical examples of acceptable bits or bosal

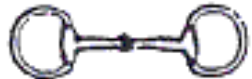

Eggbutt Snaffle Bit



O-Ring Snaffle Bit



D-Ring Snaffle Bit

## Rawhide Bosal



A bosal may also be used

## ***English Classes***

### **English Equipment**

In all English classes, an English snaffle (no shank), kimberwick, pelham and/or full bridle (with two reins), all with cavesson nosebands and plain leather brow bands must be used.

In reference to mouthpieces, nothing may protrude below the mouthpiece (bar). Solid and broken mouthpieces must be between 5/16" to 3/4" (8 mm to 20 mm) in diameter, measured 1" (25 mm) from the cheek and may have a port no higher than 1 1/2" (40 mm). They may be inlaid, synthetic wrapped, including rubber or plastic or incased, but must be smooth. Leather bits to be solid, smooth, rolled leather (15mm – 20mm) measured one inch from cheek with no port. On broken mouthpieces only, connecting rings of 1 1/4" (32 mm) or less in diameter or connecting flat bar of 3/8" to 3/4" (10 mm to 20 mm) measured top to bottom with a maximum length of 2" (50 mm), which lie flat in the horse's mouth, are acceptable. Snaffle bit rings may be no larger than 4" (100 mm) in diameter. Any bit having a fixed rein requires use of a curb chain. Smooth round, oval or egg-shaped, slow twist, corkscrew, single twisted wire, double twisted wire mouthpieces and straight bar or solid mouthpieces are allowed.

Saddles must be black and/or brown leather of traditional hunting or forward seat type, knee insert on the skirt is optional. Saddle pads should fit size and shape, except when necessary to accommodate numbers on both sides, for which a square pad or suitable attachment may be used. Saddle pads and attachments shall be white or natural color with no ornamentation.

### **English Optional Equipment**

1. Spurs of the unrowelled type that are blunt, round or that include a smooth rolling rubber ball and no longer than one inch.
2. Crops or bats.
3. Gloves.
4. English breast plate.
5. Braiding of mane and/or tail in hunt style.
6. Protective boots, leg wraps and bandages are allowed in hunt seat equitation on the flat.

### **English Prohibited Equipment**

1. Bits of any style (pelham, snaffle, kimberwick) featuring mouthpieces with cathedrals, donuts, prongs, edges or rough, sharp material shall be cause for elimination. Square stock, metal wrapped or polo bits shall be cause for elimination. If a curb bit is used, the curb chain must be at least 1/2" (15mm) in width and lie flat against the jaw of the horse.
2. Draw reins.
3. Rowelled spurs.
4. Standing or running martingales.
5. Figure 8 or flash cavessons.
6. Protective boots, leg wraps and bandages are prohibited in hunter under saddle. The use of slip on (easy care) horse boots or related footwear are not considered as protective boots and are permissible to be worn in all classes.
7. Rubber reins.
8. Slip on spurs.

### **English Attire**

1. All riders are required to wear properly fitted headgear with a fastened chin harness. ASTM/SEI helmets are required. It is the responsibility of the rider, or the parents or guardian or trainer of riders, to ensure compliance.
2. In all English classes, riders should wear hunt coats of traditional colors such as navy, dark green, grey, black or brown. Maroon and red are improper. Breeches are to be of traditional shades of buff, khaki, canary, light grey or rust (or jodhpurs), with high English boots or paddock (jodhpur) boots of black or brown. Black, navy blue or brown hard hat (with harness for youth in any over fence classes) is mandatory. A tie or choker is required. Gloves, spurs of the unrowelled type that are blunt, round or that include a smooth rolling ball and no longer than one inch and crops and bats are optional. Hair must be neat and contained (as in net or braid). Judges must penalize contestants who do not conform.
3. Judges, at their discretion, may authorize adjustments to attire due to weather-related conditions.
4. The judge will have the authority to disqualify the exhibitor for any piece of equipment, accoutrement, or attire which in his or her opinion would tend to give a rider an unfair advantage.

## Acceptable English Bits For All Ages

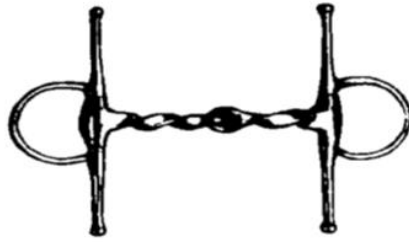

**Slow Twist**

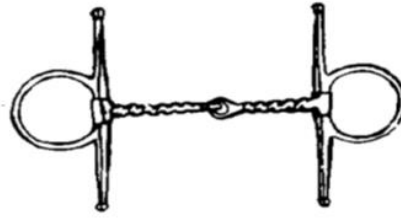

**Corkscrew**

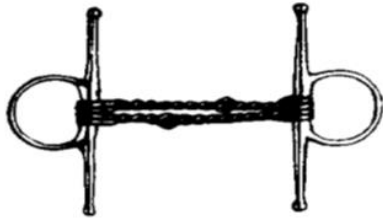

**Double Twisted Wire**



**Single Twisted Wire**

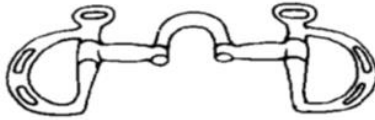

**Correction Bit**



**Snaffle Bit with  
Connecting Flat Bar**

## Unacceptable English Bits

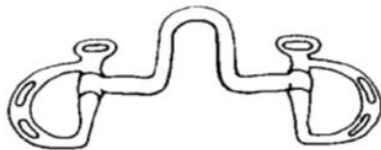

**Excessive Port**

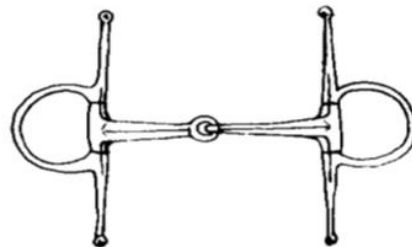

**Triangular Mouth**

# PERFORMANCE CLASSES

## SHOWMANSHIP

Showmanship is designed to evaluate the exhibitor's ability to execute, in concert with a well-groomed and conditioned horse, a set of maneuvers prescribed by the judge with precision and smoothness while exhibiting poise and confidence, and maintaining a balanced, functional and fundamentally correct body position.

- It is mandatory that the judge post the initial pattern to be worked at least one hour prior to the commencement of the class; however, if the judge requires additional work of exhibitors for consideration of final placing, an additional pattern may be posted. Pattern(s) should be designed to test the showman's ability to effectively present a horse to the judge. All ties will be broken at the judge's discretion.

**Class Procedures:** All exhibitors may enter the ring and then work individually or each exhibitor may be worked from the gate individually. When exhibitors are worked individually from the gate, a working order is required. The following maneuvers are considered acceptable: lead the horse at a walk, jog, trot or extended trot, or back in a straight or curved line, or a combination of straight and curved lines; stop; and turn 90 (1/4), 180 (1/2), 270 (3/4), 360 (full turn) degrees or any combination or multiple of these turns. The pull turn is an unacceptable maneuver. The judge must have exhibitors set the horse up squarely for inspection sometime during the class.

- Showmanship whips (dressage whips etc.), war bridles or like devices or any type of wire or rope over a horse's head are not permitted for showmanship purposes.
- A minimum gauge link of 4.0 mm is required.

**Scoring:** Exhibitors are to be scored from 0 to infinity, with 70 denoting an average performance. Patterns will be divided into 6 to 10 maneuvers, as specified by the judge, and each maneuver will be scored from +3 to -3 with 1/2 point increments acceptable that will be added or subtracted from 70. Maneuver scores should be determined independent of penalties, and should reflect equal consideration of both performance of the exhibitor's pattern and the form and effectiveness of the exhibitor and presentation of horse to result in the following scores:

- +3 Excellent
- +2 Very Good
- +1 Good
- 0 Average or Correct
- -1 Poor
- -2 Very Poor
- -3 Extremely Poor.

Exhibitors overall form and effectiveness should also be scored from 0 to 5 with 0 to 2 Average, 3 Good, 4 Very Good, 5 Excellent.

**Overall Presentation of Exhibitor and Horse.** The exhibitor's overall poise, confidence, appearance and position throughout the class, and the physical appearance of the horse will be evaluated.

**Presentation and Position of Exhibitor.** Appropriate Western or English attire may be worn; clothes and person are to be neat and clean. The use of any type of artificial aid including, but not limited to lighters, hay, dirt, sharp pins, magnetic device, etc. will result in a disqualification.

- Exhibitors should be poised, confident, courteous and genuinely sportsmanlike at all times, quickly recognizing and correcting faults in the positioning of the horse. The exhibitor should continue showing the horse until the class has been placed or they have been excused, unless otherwise instructed by the judge. The exhibitor should appear business-like, stand and move in a straight, natural and upright manner, and avoid excessive, unnatural or animated body positions.
- The exhibitor must lead on the horse's left side holding the lead shank in the right hand near the halter with the tail of the lead loosely coiled in the left hand unless requested by the judge to show the horse's teeth. It is preferable that the exhibitor's hand not be on the snap or chain portion of the lead continuously. The excess lead should never be tightly coiled, rolled or folded. When leading, the exhibitor should be positioned between the eye and the mid-point of the horse's neck, referred to as the leading position.
- Both arms should be bent at the elbow with the elbows held close to the exhibitor's side and the forearms held in a natural position. Height of the arms may vary depending on the size of the horse and exhibitor, but the arms should never be held straight out with the elbows locked.
- The position of the exhibitor when executing a turn to the right is the same as the leading position except that the exhibitor should turn and face toward the horse's head and have the horse move away from them to the right.

- When executing a back, the exhibitor should turn from the leading position to face toward the rear of the horse with the right hand extended in front of the exhibitor's chest still maintaining slight bend in the elbow and walk forward. The ideal position is for the exhibitor's left shoulder to be in alignment with the horse's left front leg.
- When setting the horse up for inspection, the exhibitor should stand angled toward the horse in a position between the horse's eye and muzzle, and should never leave the head of the horse. The exhibitor is required to use the Quarter Method when presenting the horse. The exhibitor should maintain a position that is safe for themselves and the judge. The position of the exhibitor should not obstruct the judge's view of the horse and should allow the exhibitor to maintain awareness of the judge's position at all times. The exhibitor should not crowd other exhibitors when setting up side-by-side or head-to-tail. When moving around the horse, the exhibitor should change sides in front of the horse with minimal steps and should assume the same position on the right side of the horse that they had on the left side.
- Leading, backing, turning and initiating the set-up should be performed from the left side of the horse. At no time should the exhibitor ever stand directly in front of the horse. The exhibitor should not touch the horse with their hands or feet, or visibly cue the horse by pointing their feet at the horse during the set-up.

**Presentation of Horse.** The horse's body condition and overall fitness should be assessed. The hair coat should be clean, well-brushed and in good condition. The mane, tail, forelock and wither tuft may not contain ornaments (ribbons, bows, etc.), but may be braided or banded for English or Western. The length of mane and tail may vary, as long as they are neat, clean and free of tangles. The mane should be even in length or may be roached, but the forelock and tuft over the withers must be left. The bridle path, eyebrows, and long hair on the head and legs may be clipped, except where government regulations prohibit. Hooves should be properly trimmed and if shod, the shoes should fit correctly and clinches should be neat. Hooves must be clean and may be painted black or with hoof dressings, or shown naturally. Tack should fit properly and be neat, clean and in good repair.

**Pattern Performance.** The exhibitor should perform the work accurately, precisely, smoothly, and with a reasonable amount of speed. Increasing speed of the work increases the degree of difficulty, however, accuracy and precision should not be sacrificed for speed. The horse should lead, stop, back, turn and set up willingly, briskly and readily with minimal visible or audible cueing. Severe disobedience will not result in a disqualification but should be penalized severely, and the exhibitor should not place above an exhibitor that completes the pattern correctly. Excessive schooling or training, willful abuse, loss of control of the horse by the exhibitor, failure to follow prescribed pattern, knocking over or working on the wrong side of the cones shall be cause for disqualification.

- The horse should be led directly to and away from the judge in a straight or curved line and track briskly and freely at the prescribed gait as instructed. The horse's head and neck should be straight and in line with the body.
- The stop should be straight, prompt, smooth and responsive with the horse's body remaining straight.
- The horse should back up readily with the head, neck and body aligned in a straight or curved line as instructed.
- On turns of greater than 90 degrees, the ideal turn consists of the horse pivoting on the right hind leg while stepping across and in front of the right front leg with the left front leg. An exhibitor should not be penalized if their horse performs a pivot on the left hind leg, but an exhibitor whose horse performs the pivot correctly should receive more credit.
- A pull turn to the left is an unacceptable maneuver.
- The horse should be set up quickly with the feet squarely underneath the body. The exhibitor does not have to reset a horse that stops square.

An exhibitor should be penalized in the pattern independent of maneuver scores and deducted from the final score as follows:

- **Three (3) points**
  - Break of gait at the walk or trot up to 2 strides
  - Over or under turning up to 1/4 of a turn
  - Ticking or hitting cone
  - Sliding a pivot foot
  - Lifting a pivot foot during a pivot or set-up and replacing it in the same place
  - Lifting a foot in a set-up and replacing it in the same place after presentation
- **Five (5) points**
  - Not performing the specific gait or not stopping within 10 feet (3 meters) of designated location
  - Break of gait at walk or trot for more than 2 strides
  - Splitting the cone (cone between the horse and exhibitor)
  - Horse stepping out of or moving the hind end significantly during a pivot or turn
  - Horse stepping out of set-up after presentation
  - Horse resting a foot or hipshot in a set-up
  - Over or under turning 1/8 to 1/4 turn



- **Ten (10) points**
  - Exhibitor is not in the required position during inspection
  - Exhibitor touching the horse or kicking or pointing their feet at the horse's feet during the set-up
  - Standing directly in front of the horse
  - Loss of lead shank, holding chain or two hands on shank
  - Blatant disobedience including kicking, rearing or pawing; horse continually circling exhibitor
- **Disqualifications (should not be placed) including:**
  - Loss of control of horse that endangers exhibitor, other horses, or judge
  - Horse becomes separated from exhibitor
  - Failure to display correct number
  - Willful abuse
  - Excessive schooling or training; use of artificial aids Illegal equipment
  - Off pattern, including: knocking over or wrong side of cone or marker; never performing designated gait; over or under turning more than 1/4 turn

## **WESTERN PLEASURE**

Western pleasure horses to be shown at a walk, jog, and lope both ways of the ring on a reasonably loose rein without undue restraint.

1. Horses are shown at a walk, jog or lope on a reasonable loose rein without undue restraint. Judges may ask to extend of the listed gaits. Horses must work both ways of the ring at all three gaits to demonstrate their ability with different leads. Horses may be required to reverse at the walk or trot, and may be required to go from any gait to any other gait at the discretion of the judge. For safety of the contestants, a reverse at the lope shall not be called.
2. The judge may ask that only finalists be backed.
3. Horses are to be reversed to the center of the arena.
4. Large numbers in this class will necessitate elimination heats to accommodate all horses. The suggested maximum number is 25 horses in each heat. Finalists in each heat must be brought to the center of the arena and identified.
5. This class will be judged on the performance of the horse at the discretion of the judge.
6. Reins shall be held in one hand or two hands with a snaffle bit or bosal and cannot be changed during the performance. If showing with one hand on the reins, the free hand shall not be used to support the rider by being placed on any part of the saddle.
7. Contestants must use split reins or romal—roping reins are not permitted. Only one finger between reins is permissible when using split reins.

## **WESTERN HORSEMANSHIP**

Western horsemanship is designed to evaluate the rider's ability to execute, in concert with their horse, a set of maneuvers prescribed by the judge with precision and smoothness while exhibiting poise and confidence and maintaining a balanced, functional and fundamentally correct body position. The ideal horsemanship pattern is extremely precise with the rider and horse working in complete unison, executing each maneuver with subtle aids and cues. The horse's head and neck should be carried in a relaxed, natural position, with the poll level with or slightly above the withers. The head should not be carried behind the vertical, giving the appearance of intimidation, or be excessively nosed out, giving a resistant appearance.

It is mandatory that the judge post the initial pattern to be worked at least one hour prior to the commencement of the class; however, if the judge requires additional work of exhibitors for consideration of final placing, an additional pattern may be posted. Pattern(s) should be designed to test the horseman's ability. All ties will be broken at the judge's discretion.

**Class Procedures:** All exhibitors must enter the ring and then work individually, or each exhibitor may be worked from the gate individually. When exhibitors are worked individually from the gate, a working order is required. Exhibitors should be instructed to either leave the arena, fall into line, or fall into place on the rail after their work. The whole class, or just the finalists, must work at all three gaits at least one direction of the arena. The following maneuvers are acceptable in a pattern: walk, jog, trot, extended trot, lope or extended lope in a straight line, curved line, serpentine, circle or figure 8, or combination of these gaits and maneuvers; stop; back in a straight or curved line; turn or pivot, including spins and rollbacks on the haunches and/or on the forehand; sidepass, two-track or leg-yield; flying or simple change of lead; counter-canter; or any other maneuver; or ride without stirrups. A back should be asked for at some time during the class. Judges should not ask exhibitors to mount or dismount.

**Scoring:** Exhibitors are to be scored from 0 to infinity, with 70 denoting an average performance. Patterns will be divided into 6 to 10 maneuvers, as specified by the judge, and each maneuver will be scored from +3 to -3 with 1/2 point increments acceptable that will be added or subtracted from 70. Maneuver scores should be determined independent of penalties, and should reflect equal consideration of both performance of the exhibitor's pattern and the horsemanship form and effectiveness of the exhibitor to result in the following scores:

- +3 Excellent,
- +2 Very Good
- +1 Good
- 0 Average or Correct
- -1 Poor
- -2 Very Poor
- -3 Extremely Poor

Exhibitors overall horsemanship form and effectiveness should also be scored from 0 to 5 with 0 to 2 Average, 3 Good, 4 Very Good, 5 Excellent. Exhibitors should also be judged on the rail, and their pattern score and/or ranking may be adjusted as appropriate.

**Overall Presentation of Exhibitor and Horse.** The exhibitor's overall poise, confidence, appearance and position throughout the class as well as the physical appearance of the horse will be evaluated.

**Presentation and Position of Exhibitor.** Appropriate western attire must be worn. Clothes and person are to be neat and clean. The use of any type of artificial aid or magnetic device will result in disqualification.

- The exhibitor should appear natural in the seat and ride with a balanced, functional and correct position regardless of the maneuver or gait being performed. During the railwork and pattern, the exhibitor should have strong, secure and proper position. Exhibitors should sit and maintain an upright position with the upper body at all gaits.
- The rider should sit in the center of the saddle and the horse's back with the legs hanging to form a straight line from the ear, through the center of the shoulder and hip, touching the back of the heel or through the ankle. The heels should be lower than the toes, with a slight bend in the knee and the lower leg should be directly under the knee. The rider's back should be flat, relaxed and supple. An overly stiff and/or overly arched lower back will be penalized. The shoulders should be back, level and square. The rider's base of support should maintain secure contact with the saddle from the seat to the inner thigh. Light contact should be maintained with the saddle and horse from the knee to mid-calf. The knee should point forward and remain closed with no space between the exhibitor's knee and the saddle. The exhibitor will be penalized for positioning the legs excessively behind or forward of the vertical position. Regardless of the type of stirrup, the feet may be placed home in the stirrup, with the boot heel touching the stirrup, or may be placed with the ball of the foot in the center of the stirrup. The rider's toes should be pointing straight ahead or slightly turned out with the ankles straight or slightly broken in. Riding with toes only in the stirrup and riding without contact of bottom of boot securely on pad of stirrup, will be penalized. Those exhibitors that can maintain the proper position throughout all maneuvers should receive more credit. When riding without stirrups, the exhibitor should maintain the same position as previously described. Both hands and arms should be held in a relaxed, easy manner, with the upper arm in a straight line with the body. The arm holding the reins should be bent at the

elbow forming a line from the elbow to the horse's mouth. The free hand and arm may be carried bent at the elbow in a similar position as the hand holding the reins or straight down at the rider's side. Excessive pumping of the free arm as well as excessive stiffness will be penalized. The rider's wrist is to be kept straight and relaxed, with the hand held at about 30 to 45 degrees inside the vertical. The rein hand should be carried immediately above or slightly in front of the saddle horn. The reins should be adjusted so that the rider has light contact with the horse's mouth, and at no time shall reins require more than a slight hand movement to control the horse. Excessively tight or loose reins will be penalized.

- The rider's head should be held with the chin level and the eyes forward, and may be directed slightly toward the direction of travel. Excessive turning of the head to the inside of the circle, or down at the horse's head or shoulder will be penalized.
- The exhibitor should not crowd the exhibitor next to or in front of them when working on the rail and should pass to the inside of the arena. When reversing on the rail, the exhibitor should always reverse to the inside of the arena.

**Presentation of Horse.** The horse's body condition and overall health and fitness should be assessed. The horse should appear fit and carry weight appropriate for the body size. A horse which appears sullen, dull, lethargic, emaciated, drawn or overly tired should be penalized according to severity. Tack should fit the horse properly and be neat, clean and in good repair.

**Pattern Performance.** The exhibitor should perform the work accurately, precisely, smoothly, and with a reasonable amount of promptness. Increasing speed of the maneuvers performed increases the degree of difficulty; however, accuracy and precision should not be sacrificed for speed. Exhibitors that perform the pattern sluggishly and allow their horse to move without adequate impulsion, collection or cadence will be penalized.

- The horse should perform all maneuvers in the pattern willingly, briskly and readily with minimal visible or audible cueing. Severe disobedience will not result in a disqualification, but should be severely penalized, and the exhibitor should not place above an exhibitor that completes the pattern correctly. Failure to follow the prescribed pattern, knocking over or working on the wrong side of the cones, excessive schooling or training, or willful abuse by the exhibitor is cause for disqualification.
- The horse should track straight, freely and at the proper cadence for the prescribed gait. Transitions should be smooth and prompt in the pattern and on the rail, and should be performed when called for on the rail. The horse's head and neck should be straight and in line with their body while performing straight lines and slightly arched to the inside on curved lines or circles. Circles should be round and performed at the appropriate speed, size and location as requested in the pattern. The counter-canter should be performed smoothly with no change in cadence or stride unless specified in the pattern.
- The stop should be straight, square, prompt, smooth and responsive with the horse maintaining a straight body position throughout the maneuver. The back should be smooth and responsive.
- Turns should be smooth and continuous. When performing a turn on the haunches, the horse should pivot on the inside hind leg and step across with the front legs. A rollback is a stop and 180 degree turn over the hocks with no hesitation. Backing during turns will be penalized severely.
- The horse should step across with the front and hind legs when performing the sidepass, leg-yield and two-track. The side pass should be performed with the horse keeping the body straight while moving directly lateral in the specified direction. When performing a leg-yield, the horse should move forward and lateral in a diagonal direction with the horse's body arced opposite to the direction that the horse is moving. In the two-track, the horse should move forward and lateral in a diagonal direction with the horse's body held straight or bent in the direction the horse is moving.
- A simple or flying change of lead should be executed precisely in the specified number of strides and/or at the designated location. A simple change of lead is performed by breaking to a walk or trot for one to three strides. Flying changes should be simultaneous front and rear. All changes should be smooth and timely.
- Position of the exhibitor and performance of the horse and rider on the rail must be considered in the final placing.

**Penalties.** An exhibitor should be penalized in the pattern independent of maneuver scores and deducted from the final score as follows:

- **Three (3) points**
  - Break of gait at the walk or jog up to 2 strides
  - Over or under turn from 1/8 to 1/4 turn
  - Tick or hit of cone
- **Five (5) points**
  - Not performing the specific gait or not stopping within 10 feet (3 meters) of designated location
  - Obviously looking down to check leads
  - Incorrect lead or break of gait at the lope (except when correcting an incorrect lead)
  - Break of gait at walk or jog for more than 2 strides
  - Loss of stirrup
  - Bottom of boot not touching pad of stirrup at all gaits including backup
  - Head carried too low and/or clearly behind the vertical while the horse is in motion, showing the appearance of intimidation

- **Ten (10) points**
  - Loss of rein
  - Use of either hand to instill fear or praise while on pattern or during rail work
  - Holding saddle with either hand
  - Cueing with the end of the romal
  - Blatant disobedience including kicking, pawing, bucking, and rearing
  - Spurring in front of the cinch
- **Disqualifications (should not be placed) including:**
  - Failure to display correct number
  - Abuse of horse or schooling
  - Fall by horse or exhibitor
  - Illegal equipment or illegal use of hands on reins
  - Use of prohibited equipment
  - Off pattern, including: knocking over or wrong side of cone or marker; never performing designated gait or lead; over or under turning more than 1/4 turn

## **REINING**

1. Each horse will be judged on the neatness, dispatch, ease, calmness and speed with which it performs the pattern. See patterns attached.
2. Any horse not following the exact pattern will be disqualified.
3. All contestants are eligible to enter the reining class.

**SCORING.** Scoring will be on the basis of 0-Infinity, with 70 denoting an average performance. Points will be added or subtracted from the maneuvers on the following bases, ranging from plus 1 1/2 to minus 1 1/2: -1 1/2 extremely poor, -1 very poor, -1/2 poor, 0 average, +1/2 good, +1 very good, +1 1/2 excellent. Maneuver scores are to be determined independently of penalty points.

### **Penalties:**

- **No Score**
  - Abuse of an animal in the show arena and/or evidence that an act of abuse has occurred prior to or during the exhibition of a horse in competition
  - Use of illegal equipment, including wire on bits, bosals or curb chains; Use of illegal bits, bosals or curb chains; when using a snaffle bit, optional curb strap is acceptable; however, curb chains are not acceptable.
  - Use of tack collars, tie downs or nose bands; Use of whips or bats
  - Use of any attachment which alters the movement of or circulation to the tail;
  - Failure to provide horse and equipment to the appropriate judge for inspection
  - Disrespect or misconduct by the exhibitor
  - Closed reins are not allowed except as standard romal reins.
  - Excess rein may be straightened anytime during the pattern, provided the rider's free hand remains behind the rein hand. Any attempt to alter tension or length of the reins from bridle to the rein hand is to be considered use of two hands a penalty score of zero will be applied. In addition, should the judge determine the free hand is being used to instill fear or praise, a penalty five will be applied, and a reduction in the maneuver score
- **Score of 0**
  - Use of more than index or first finger between reins
  - Use of two hands (exception in junior, snaffle bit, or hackamore classes designated for two hands) or changing hands
  - Use of romal other than as outlined in WESTERN EQUIPMENT
  - Failure to complete pattern as written
  - Performing the maneuvers other than in specified order;
  - The inclusion of maneuvers not specified, including, but not limited to Backing more than two strides
  - Turning more than 90 degrees
  - Equipment failure that delays completion of pattern; including dropping a rein that contacts the ground while horse is in motion
  - Balking or refusal of command where performance is delayed
  - Running away or failing to guide where it becomes impossible to discern whether the entry is on pattern
  - Jogging in excess of one-half circle or one-half the length of the arena
  - Overspins of more than 1/4 turn

- Fall to the ground by horse or rider
- When going to and coming out of a rollback in a pattern requiring a run-around, a rollback that crosses the center line
- **Five (5) points**
  - Spurring in front of cinch
  - Use of either hand to instill fear or praise
  - Holding saddle with either hand
  - Blatant disobediences including kicking, biting, bucking, rearing and striking.
- **Two (2) points**
  - Break of gait
  - Freeze up in spins or rollbacks
  - On walk-in patterns, failure to stop or walk before executing a canter departure
  - On run-in patterns, failure to be in a canter prior to the first marker.
  - If a horse does not completely pass the specified marker before initiating a stop position

***Starting or performing circles or eights out of lead will be judged as follows:*** Each time a horse is out of lead, a judge is required to deduct one point. The penalty for being out of lead is cumulative and the judge will deduct one penalty point for each quarter of the circumference of a circle or any part thereof that a horse is out of lead. A judge is required to penalize a horse 1/2 point for a delayed change of lead by one stride where the lead change is required by the pattern description.

- Starting circle at a jog or exiting rollbacks at a jog up to two strides, **deduct a 1/2 point.**
- Jogging beyond two strides, but less than 1/2 circle or 1/2 the length of the arena, **deduct two points.**
- For over or under spinning up to 1/8 of turn deduct **a 1/2 point.**
- Deduct **one point** for over or under spinning 1/8 to 1/4 turn
- Failure to remain a minimum of 20 feet (6 meters) from the wall or fence when approaching a stop and/or rollback **deduct a 1/2 point.**
- In patterns requiring a run-around, failure to be on the correct lead when rounding the end of the arena will be penalized as follows: for 1/2 the turn or less, **one point**; for more than 1/2 turn, **two points.**
- In a pattern requiring a run-around, there will be a **1/2 point** penalty for failure to remain a minimum of 10 feet from either side of the center of the arena; for small arenas it will be at the judge's discretion.

## Reining Pattern 1

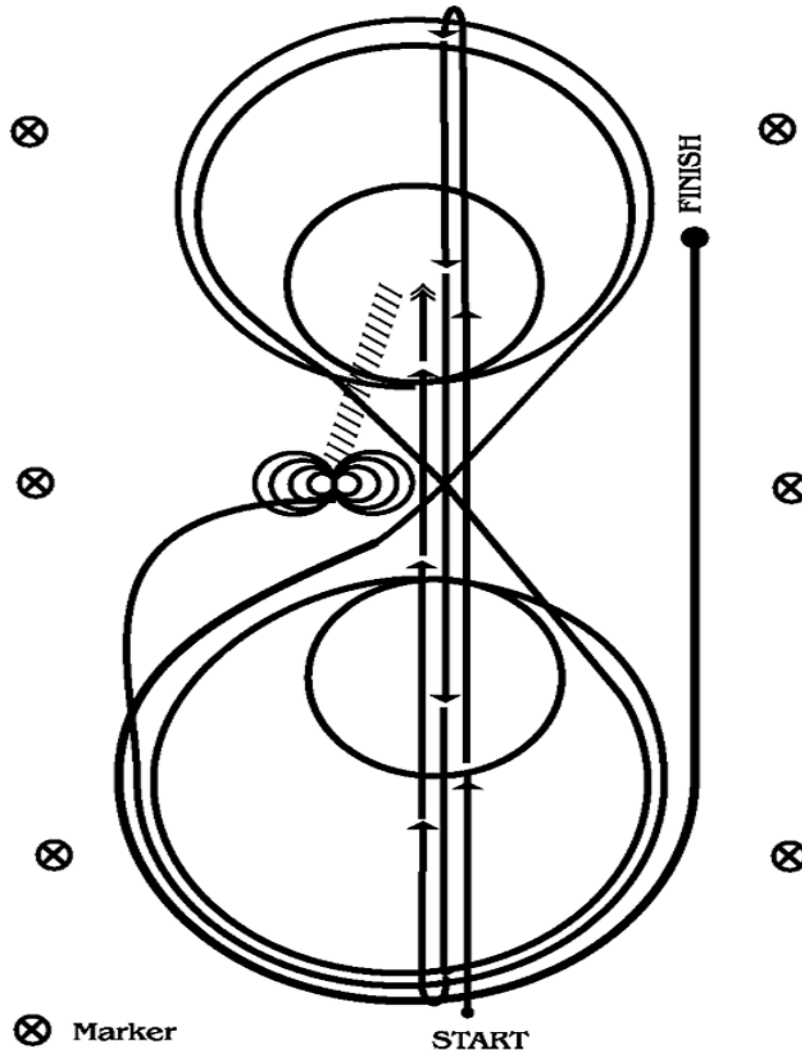

1. Run at speed to the far end of the arena past the end marker and do a left rollback - no hesitation.
2. Run to the opposite end of the arena past the end marker and do a right rollback - no hesitation.
3. Run past the center marker and do a sliding stop. Back up to center of the arena or at least ten feet (3 meters). Hesitate.
4. Complete four spins to the right.
5. Complete four and one-quarter spins to the left so that horse is facing left wall or fence. Hesitate.
6. Beginning on the left lead, complete three circles to the left: the first circle large and fast; the second circle small and slow; the third circle large and fast. Change leads at the center of the arena.
7. Complete three circles to the right: the first circle large and fast; the second circle small and slow; the third circle large and fast. Change leads at the center of the arena.
8. Begin a large fast circle to the left but do not close this circle. Run straight up the right side of the arena past the center marker and do a sliding stop at least 20 feet (6 meters) from wall or fence. Hesitate to demonstrate the completion of the pattern.

## Reining Pattern 2

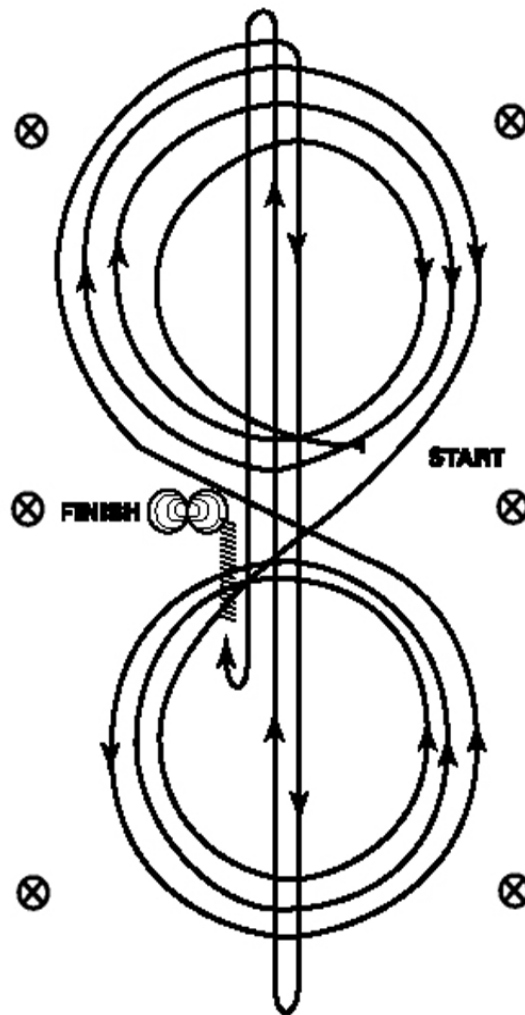

1. Beginning on the right lead, complete three circles to the right: the first circle small and slow; the next two circles large and fast. Change leads at the center of the arena.
2. Complete three circles to the left: the first circle small and slow; the next two circles large and fast. Change leads at the center of the arena.
3. Continue around previous circle to the right. At the top of the circle, run down the middle to the far end of the arena past the end marker and do a right rollback - no hesitation.
4. Run up the middle to the opposite end of the arena past the end marker and do a left rollback - no hesitation.
5. Run past the center marker and do a sliding stop. Back up to the center of the arena or at least 10 feet (3 meters). Hesitate.
6. Complete four spins to the right.
7. Complete four spins to the left. Hesitate to demonstrate the completion of the pattern.

## Reining Pattern 3

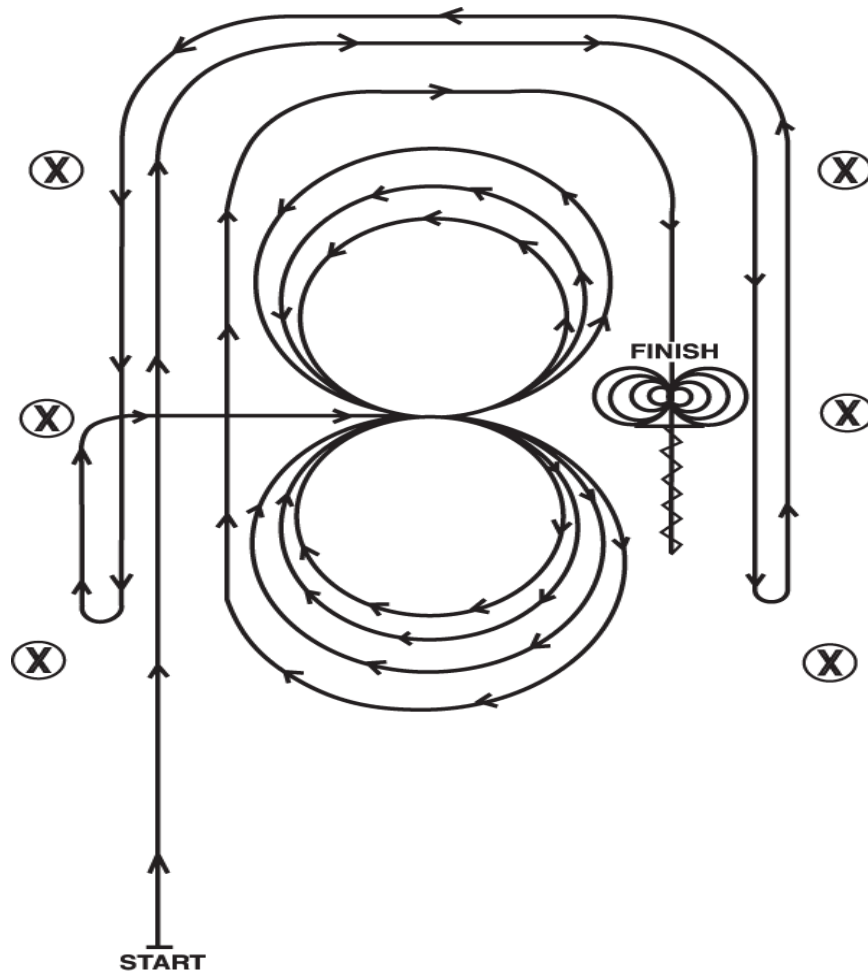

○ MARKER

1. Beginning, and staying at least 20 feet (6 meters) from the walls or fence, lope straight up the left side of the arena, circle the top end of the arena, run straight down the opposite or right side of the arena past the center marker and do a left rollback - no hesitation.
2. Continue straight up the right side of the arena staying at least 20 feet (6 meters) from the wall or fence, circle back around the top of the arena, run straight down the left side of the arena past the center marker and do a right rollback - no hesitation.
3. Continue up the left side of the arena to the center marker. At the center marker, the horse should be on the right lead. Guide the horse to the center of the arena on the right lead and complete three circles to the right: the first two circles large and fast; the third circle small and slow. Change leads at the center of the arena.
4. Complete three circles to the left: the first two circles large and fast; the third circle small and slow. Change leads in the center of the arena.
5. Begin a large fast circle to the right but do not close this circle. Continue up the left side of the arena staying at least 20 feet (6 meters) from the wall or fence, circle the top of the arena, run straight down the opposite or right side of the arena past the center marker and do a sliding stop. Back up at least 10 feet (3 meters). Hesitate.
6. Complete four spins to the right.
7. Complete four spins to the left. Hesitate to demonstrate completion of the pattern.



## Reining Pattern 4

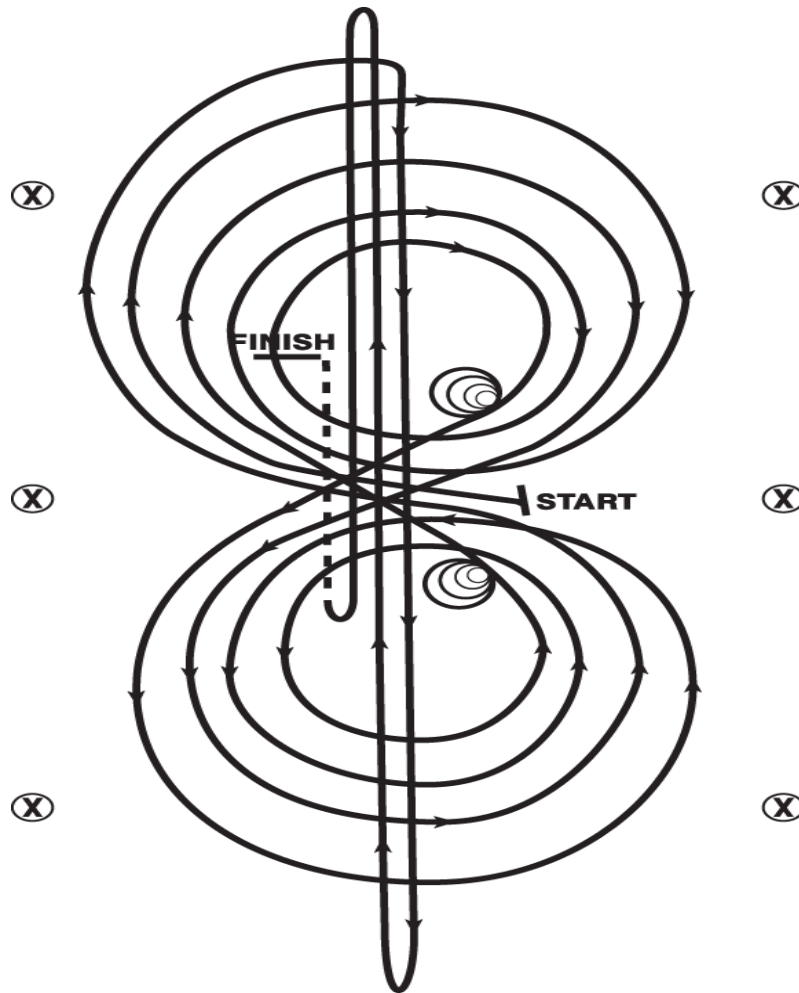

Horse must walk or stop prior to starting pattern.

Beginning at the center of the arena facing the left wall or fence.

1. Beginning on the right lead, complete three circles to the right: the first two circles large and fast; the third circle small and slow. Stop at the center of the arena.
2. Complete four spins to the right. Hesitate.
3. Beginning on the left lead, complete three circles to the left: the first two circles large and fast; the third circle small and slow. Stop at the center of the arena.
4. Complete four spins to the left. Hesitate.
5. Beginning on the right lead, run a large fast circle to the right, change leads at the center of the arena, run a large fast circle to the left, and change leads at the center of the arena.
6. Continue around previous circle to the right. At the top of the circle, run down the middle to the far end of the arena past the end marker and do a right rollback - no hesitation.
7. Run up the middle to the opposite end of the arena past the end marker and do a left rollback - no hesitation.
8. Run past the center marker and do a sliding stop. Back up to the center of the arena or at least 10 feet (3 meters). Hesitate to demonstrate completion of the pattern.

## Reining Pattern 5

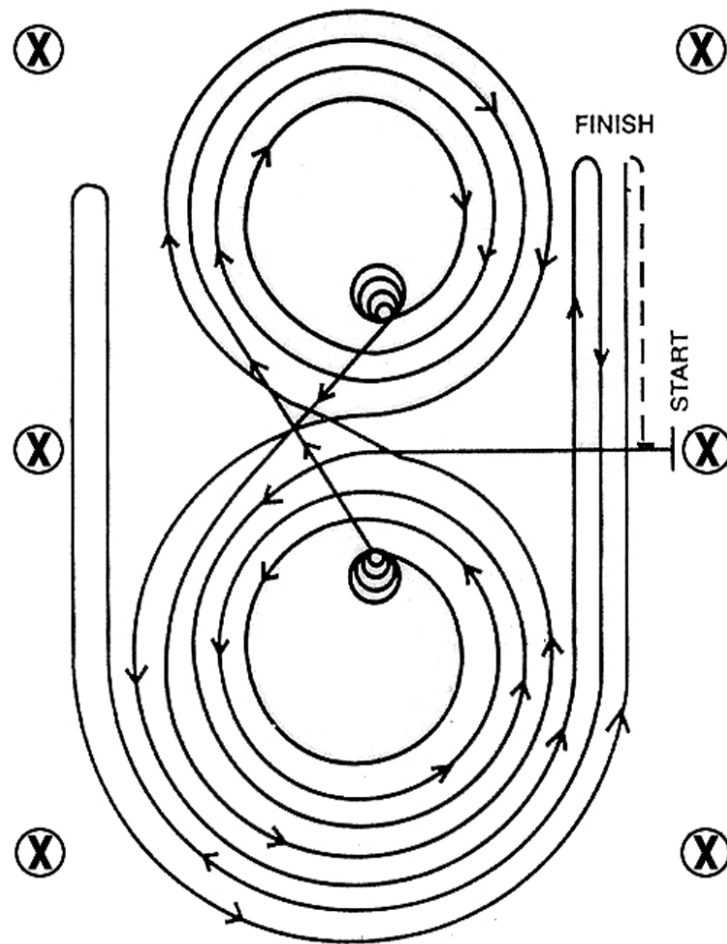

Horse must walk or stop prior to starting pattern.

Beginning at the center of the arena facing the left wall or fence.

1. Beginning on the left lead, complete three circles to the left: the first two circles large and fast; the third circle small and slow. Stop at the center of the arena.
2. Complete four spins to the left. Hesitate.
3. Beginning on the right lead, complete three circles to the right: the first two circles large and fast; the third circle small and slow. Stop at the center of the arena.
4. Complete four spins to the right. Hesitate.
5. Beginning on the left lead, run a large fast circle to the left, change leads at the center of the arena, run a large fast circle to the right, and change leads at the center of the arena. (Figure 8)
6. Continue around previous circle to the left but do not close this circle. Run up the right side of the arena past the center marker and do a right rollback at least 20 feet (6 meters) from the wall or fence - no hesitation.
7. Continue around previous circle but do not close this circle. Run up the left side of the arena past the center marker and do a left rollback at least 20 feet (6 meters) from the wall or fence - no hesitation.
8. Continue back around previous circle but do not close this circle. Run up the right side of the arena past the center marker and do a sliding stop at least 20 feet (6 meters) from the wall or fence. Back up at least 10 feet (3 meters). Hesitate to demonstrate completion of the pattern.

## Reining Pattern 6

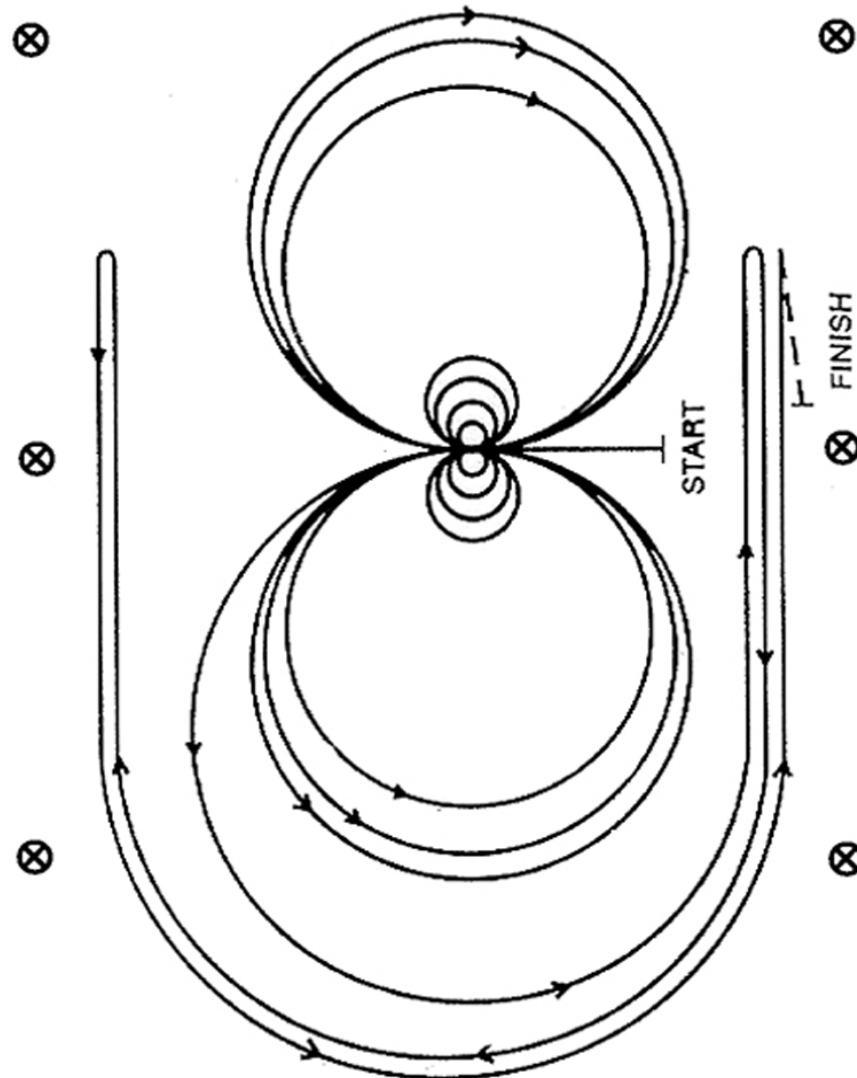

Horse must walk or stop prior to starting pattern.  
Beginning at the center of the arena facing the left wall or fence.

1. Complete four spins to the right.
2. Complete four spins to the left. Hesitate.
3. Beginning on the left lead, complete three circles to the left: the first two circles large and fast; the third circle small and slow. Change leads at the center of the arena.
4. Complete three circles to the right: the first two circles large and fast; the third circle small and slow. Change leads at the center of the arena.
5. Begin a large fast circle to the left but do not close this circle. Run up the right side of the arena past the center marker and do a right rollback at least 20 feet (6 meters) from the wall or fence - no -hesitation.
6. Continue back around previous circle but do not close this circle. Run up the left side of the arena past the center marker and do a left rollback at least 20 feet (6 meters) from the wall or fence - no -hesitation.
7. Continue back around previous circle but do not close this circle. Run up the right side of the arena past the center marker and do a sliding stop at least 20 feet (6 meters) from the wall or fence. Back up at least 10 feet (3 meters). Hesitate to demonstrate the completion of the -pattern.

## Reining Pattern 7

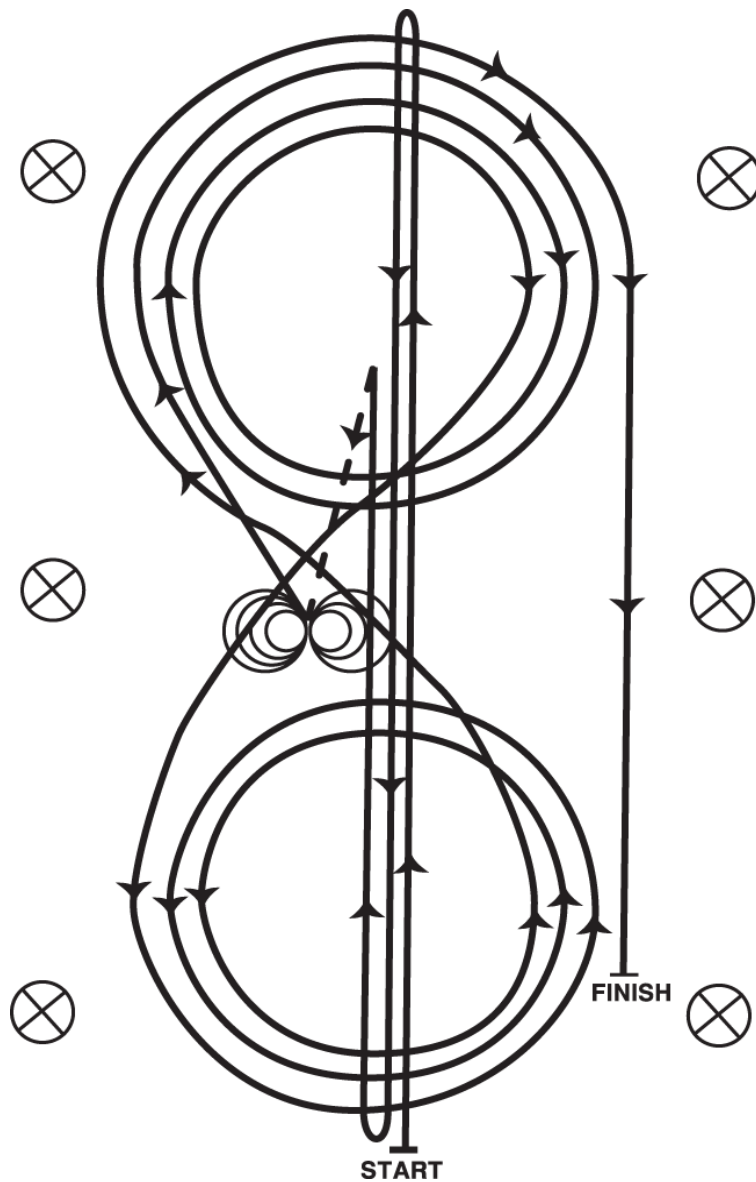

1. Run at speed to the far end of the arena past the end -marker and do a left rollback - no hesitation.
2. Run to the opposite end of the arena past the end marker and do a right rollback - no hesitation.
3. Run past the center marker and do a sliding stop. Back up to the center of the arena or at least ten feet (3 meters). Hesitate.
4. Complete four spins to the right.
5. Complete four and one-quarter spins to the left so that horse is facing left wall or fence. Hesitate.
6. Beginning on the right lead, complete three circles to the right: the first two circles large and fast; the third circle small and slow. Change leads at the center of the arena.
7. Complete three circles to the left: the first two circles large and -fast; the third circle small and slow. Change leads at the center of the arena.
8. Begin a large fast circle to the right but do not close this circle. Run straight down the right side of the arena past the center marker and do a sliding stop at least 20 feet (6 meters) from the wall or fence. Hesitate to demonstrate completion of the pattern.

## Reining Pattern 8

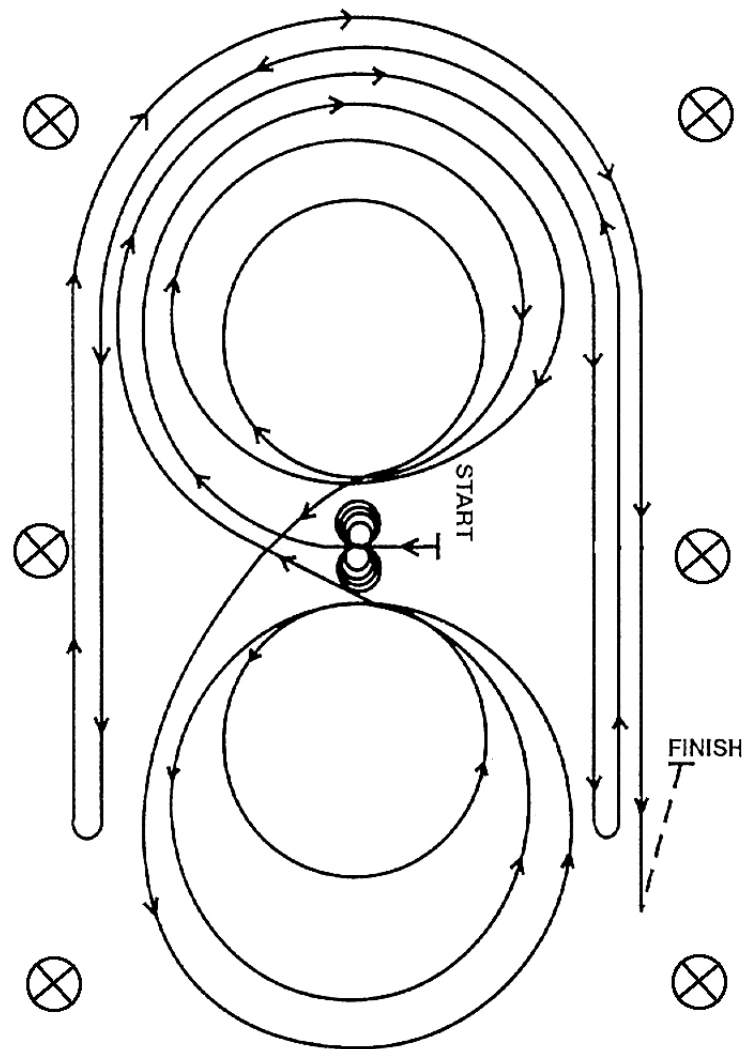

1. Complete four spins to the left.
2. Complete four spins to the right. Hesitate.
3. Beginning on the right lead, complete three circles to the right: the first circle large and fast; the second circle small and slow; the third circle large and fast. Change leads at the center of the arena.
4. Complete three circles to the left: the first circle large and fast; the second circle small and slow; the third circle large and fast. Change leads at the center of the arena.
5. Begin a large fast circle to the right but do not close this circle. Run straight down the right side of the arena past the center marker and do a left rollback at least 20 feet (6 meters) from the wall or fence - no hesitation.
6. Continue back around the previous circle but do not close this circle. Run down the left side of the arena past the center marker and do a right rollback at least 20 feet (6 meters) from the wall or fence - no hesitation.
7. Continue back around the previous circle but do not close this circle. Run down the right side of the arena past the center marker and do a sliding stop at least 20 feet (6 meters) from the wall or fence. Back up at least 10 feet. Hesitate to demonstrate completion of the pattern.

## Reining Pattern 9

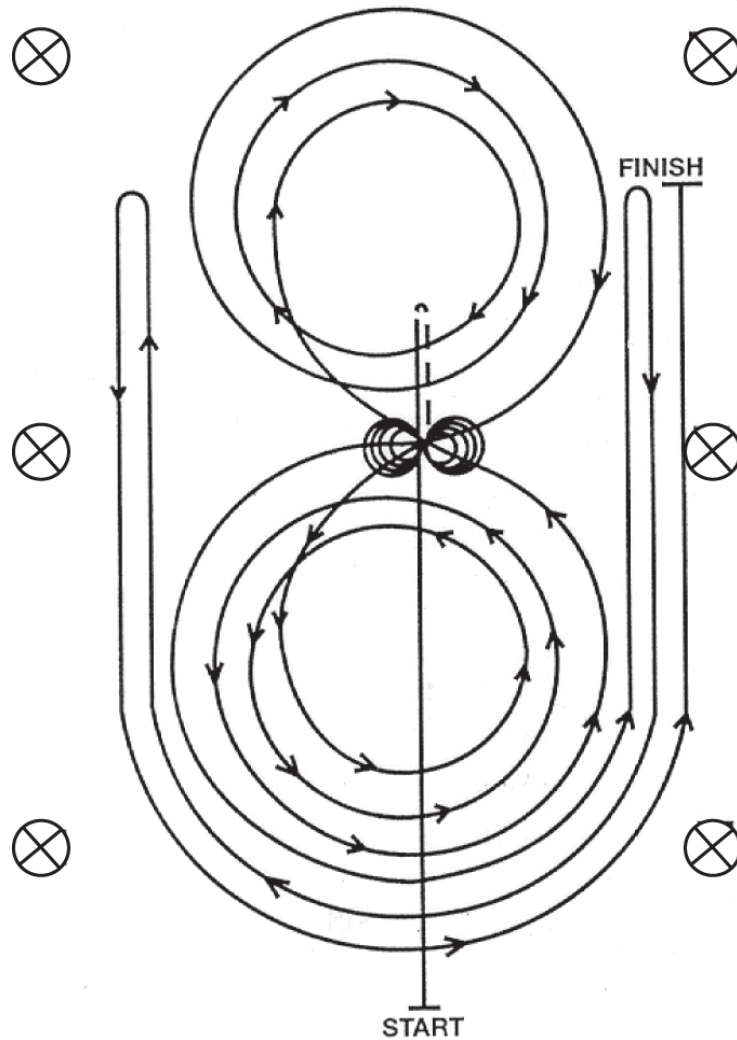

1. Run past the center marker and do a sliding stop. Back up to the center of the arena or at least 10 feet (3 meters). Hesitate.
2. Complete four spins to the right.
3. Complete four and one-quarter spins to the left so that horse is facing the left wall or fence. Hesitate.
4. Beginning on the left lead, complete three circles to the left: the first circle small and slow; the next two circles large and fast. Change leads at the center of the arena.
5. Complete three circles to the right: the first circle small and slow; the next two circles large and fast. Change leads at the center of the arena.
6. Begin a large fast circle to the left but do not close this circle. Run up the right side of the arena past the center marker and do a right rollback at least 20 feet (6 meters) from the wall or fence - no hesitation.
7. Continue back around the previous circle but do not close this circle. Run up the left side of the arena past the center marker and do a left rollback at least 20 feet (6 meters) from the wall or fence - no hesitation.
8. Continue back around previous circle but do not close this -circle. Run up right side of the arena past the center marker and do a sliding stop at least 20 feet (6 meters) from the wall or fence. Hesitate to demonstrate completion of the pattern.

## Reining Pattern 10

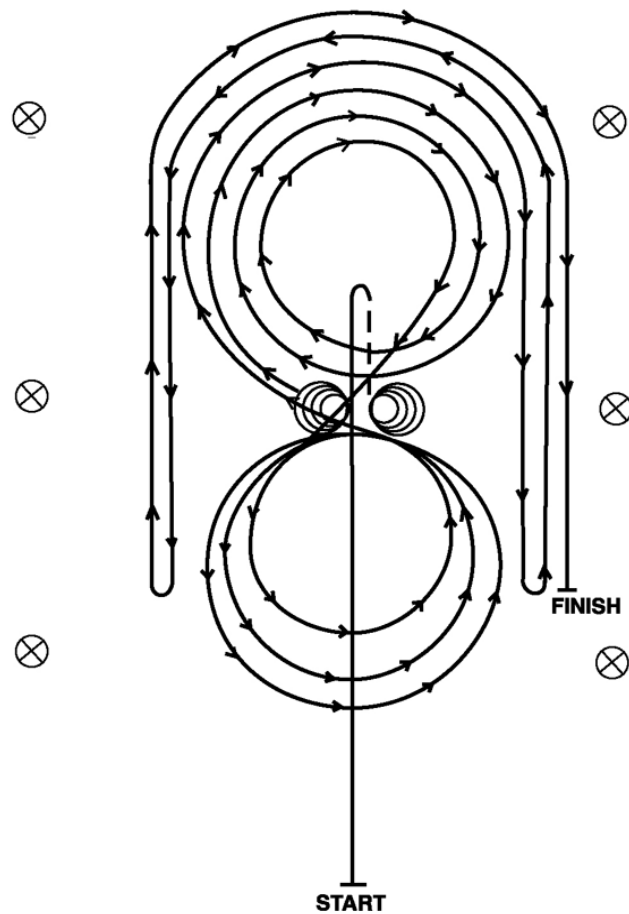

⊗ MARKER

1. Run past the center marker and do a sliding stop. Back up to the center of the arena or at least 10 feet (3 meters). Hesitate.
2. Complete four spins to the right.
3. Complete four and one-quarter spins to the left so that the horse is facing the left wall or fence. Hesitate.
4. Beginning on the right lead, complete three circles to the right: the first two circles large and fast, the third circle small and slow. Change leads at the center of the arena.
5. Complete three circles to the left: the first circle small and slow, the next two circles large and fast. Change leads at the center of the arena.
6. Begin a large fast circle to the right but do not close this -circle. Run down the right side of the arena past the marker and do a left rollback at least 20 feet (6 meters) from the wall or fence - no hesitation.
7. Continue back around the previous circle but do not close this circle. Run down the left side of the arena past the center and do a right rollback at least 20 feet (6 meters) from the wall or fence - no -hesitation.
8. Continue back around previous circle but do not close this -circle. Run down the right side of the arena past the center marker and do a sliding stop at least 20 feet (6 meters) from the wall or fence. Hesitate to demonstrate completion of the pattern.

## Reining Pattern 11

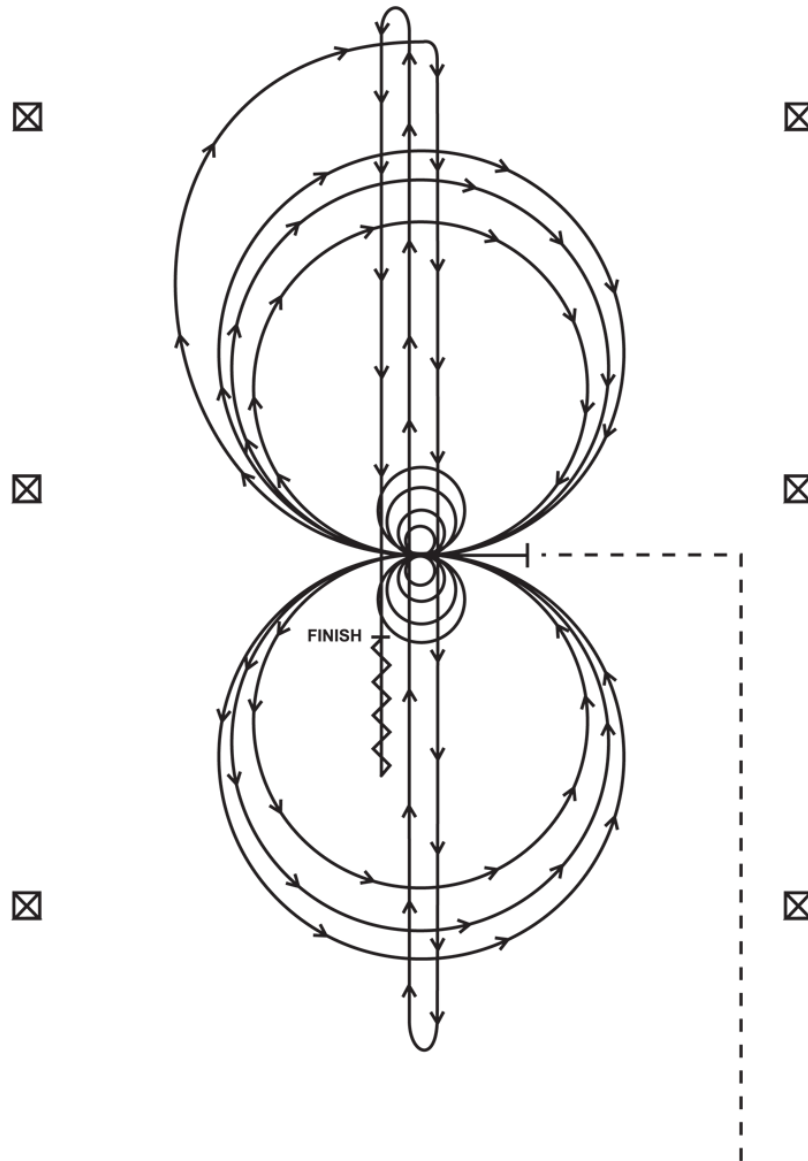

1. Complete four spins to the left. Hesitate.
2. Complete four spins to the right. Hesitate.
3. Beginning on the right lead, complete three circles to the right; the first circle small and slow; the next two circles large and fast. Change leads at the center of the arena.
4. Complete three circles to the left; the first circle small and slow; the next two circles large and fast. Change leads at the center of the arena.
5. Begin a large circle to the right, but do not close this circle. Run down the center of the arena past the end marker and do a right rollback - no hesitation.
6. Run up the middle to the opposite end of the arena past the end marker and do a left rollback - no hesitation.
7. Run past the center marker and do a sliding stop. Back up to the center of the arena or at least ten feet (three meters).

Hesitate to demonstrate completion of the pattern.



## **WESTERN RIDING**

1. Western riding is an event where the horse is judged on quality of gaits, lead changes at the lope, response to the rider, manners, and disposition. The horse should perform with reasonable speed, and be sensible, well-mannered, free and easy-moving. AQHA Novice Western Riding rules will apply (more than four simple lead changes are permissible without receiving a score of 0).
2. Credit shall be given for and emphasis placed on smoothness, even cadence of gaits (i.e., starting and finishing pattern with the same cadence), and the horse's ability to change leads precisely, easily and simultaneously both hind and front at the center point between markers. The horse should have a relaxed head carriage showing response to the rider's hands, with a moderate flexion at the poll. Horses may be ridden with light contact or on a reasonably loose rein. The horse should cross the log both at the jog and the lope without breaking gait or radically changing stride.
3. The judge will select a pattern from one of the AQHA Western Riding patterns. The judge is responsible for the pattern being correctly set.
4. The pattern:
  - a. The eight small circles represent pylon markers which are recommended. These should be separated by a uniform measured distance of not less than 30 feet, not more than 20 feet on the sides with five markers (see diagram). In pattern one, the three markers on the opposite side should be set adjacent to the appropriate markers. It is recommended that markers be set a minimum of 15 feet from the fence and with 50- to 80-foot width in the pattern, as the arena permits.
  - b. A solid log or pole should be used and be a minimum of 8 feet in length.
  - c. The long serpentine line indicates the direction of travel and gaits at which the horse is to move. The recommended lead changing point is equal to one-half stride length before or after the center point between the markers. The dotted line (...) indicates walk, the dash line (- - -) jog, and the solid line (\_\_\_) lope.
5. Scoring will be on basis of 0 – 100, with 70 denoting an average performance.
  - a. Scoring guidelines to be considered: points will be added or subtracted from the maneuvers on the following basis, ranging from 1.5 to -1.5, as in the following examples: -1.5 extremely poor, -1 very poor, -0.5 poor, 0 average, +5 good, +1 very good, +1.5 excellent. Maneuver scores are to be determined independently of penalty points.
6. A contestant shall be penalized each time the following occur:
  - **Five (5) points**
    - Failure to change leads
    - Kicking out
    - Blatant disobedience
  - **Three (3) points**
    - Not performing the specific gait (jog or lope) or stopping when called for in the pattern, within 10 feet of the designated area
    - Break of gait at the lope
    - Simple change of leads
    - Failure to change after one stride but changes before next designated change area
    - Additional lead changes anywhere in pattern
    - In pattern one, failure to start the lope within 30 feet after crossing the log at the jog
    - Break of gait at walk or jog for two or more strides

- **One (1) point**
    - Break of gait at walk or jog up to two strides
    - Hitting or rolling jog
    - Failure to change leads for one stride
    - Splitting the log (log between the two front or two hind feet) at the lope
    - Hind legs skipping or coming together during lead change
    - Failure to change leads from one-half to one stride
  - **One-half (1/2) point**
    - Tick or light touch of log
- e. **Zero score**
- 1) Fall to ground by horse or rider
  - 2) Illegal equipment
  - 3) Willful abuse
  - 4) Off course
  - 5) Knocking over markers
  - 6) Completely missing log
  - 7) Major refusal – stop and back two strides or four steps with front legs
  - 8) Major disobedience – rearing, schooling
  - 9) Failure to start lope prior to end cone in pattern No. 1
  - 10) If an exhibitor completes 4 or more simple lead changes or fails to change leads 4 or more times, he or show will receive a Score of 0.
- f. **Credits**
- 1) Changes of leads, hind and front simultaneously
  - 2) Changes at designated point
  - 3) Accurate and smooth pattern
  - 4) Even pace throughout
  - 5) Easy to guide and control with rein and leg
  - 6) Manners and disposition
  - 7) Conformation and fitness
- g. **The following characteristics are considered faults and should be judged accordingly in maneuver scores:**
- 1) Opening mouth excessively
  - 2) Anticipating signals or early lead changes
  - 3) Stumbling

## WESTERN RIDING PATTERN I

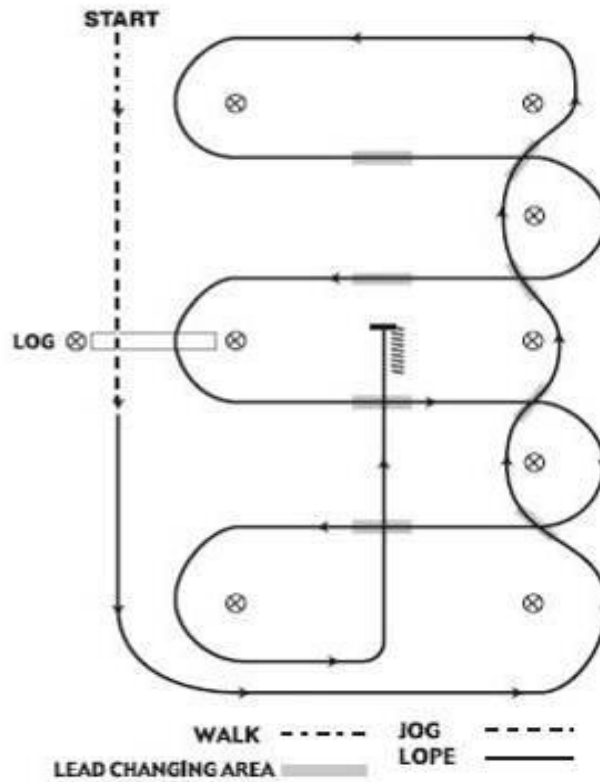

1. Walk at least 15 feet and jog over log
2. Transition to left lead and lope around end
3. First line change
4. Second line change
5. Third line change
6. Fourth line change, lope around the end of arena
7. First crossing change
8. Second crossing change
9. Lope over log
10. Third crossing change
11. Fourth crossing change
12. Lope up the center, stop and back

## WESTERN RIDING PATTERN II

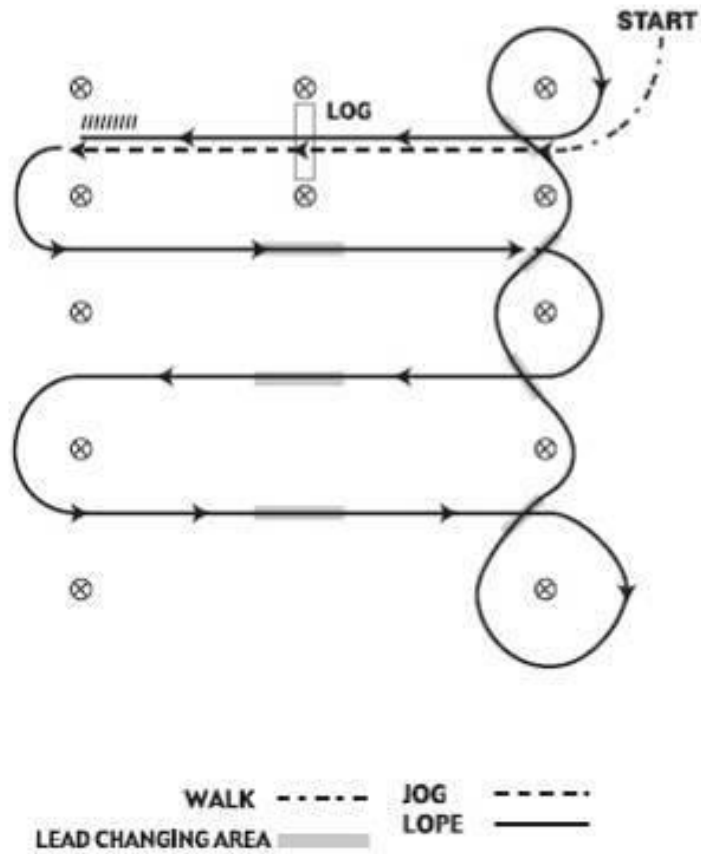

1. Walk, transition to jog, jog over log
2. Transition to the lope, on the left lead
3. First crossing change
4. Second crossing change
5. Third crossing change
6. Circle and first line change
7. Second line change
8. Third line change
9. Fourth line change and circle
10. Lope over log
11. Lope, stop and back

### WESTERN RIDING PATTERN III

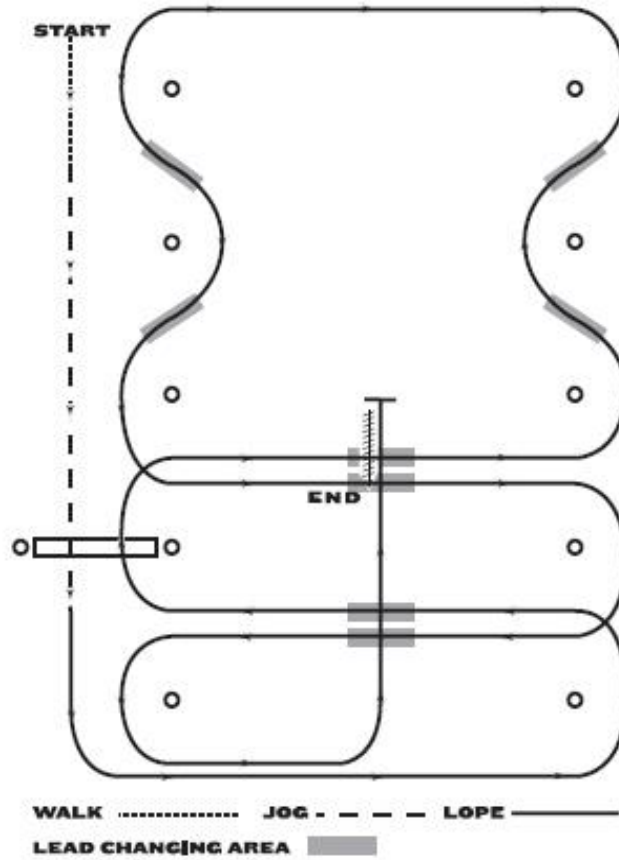

1. Walk halfway between markers, transition to jog, jog over log
2. Transition to the lope, on the left lead
3. First crossing change
4. Lope over log
5. Second crossing change
6. First line change
7. Second line change
8. Third line change
9. Fourth line change
10. Third crossing change
11. Fourth crossing change
12. Lope up the center, stop, and back

## WESTERN RIDING PATTERN IV

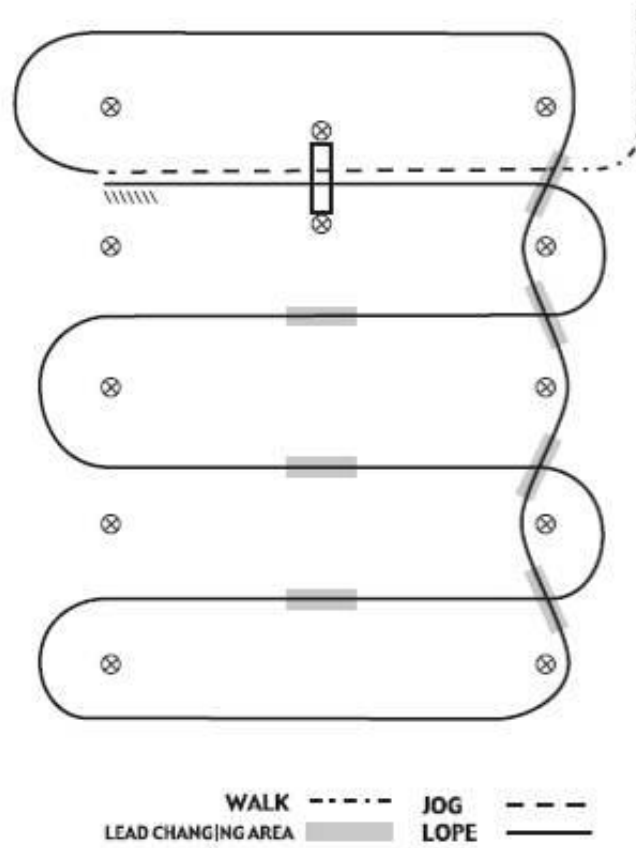

1. Walk, transition to jog, jog over log
2. Transition to the lope, on the right lead
3. First line change
4. Second line change
5. Third line change
6. Fourth line change
7. First crossing change
8. Second crossing change
9. Third crossing change
10. Lope over log
11. Lope, stop and back

## TRAIL

1. This class will be judged on the performance of the horse over obstacles, with emphasis on manners, response to the rider and quality of movement. Credit will be given to horses negotiating the obstacles with style and some degree of speed, providing correctness is not sacrificed. Horses should receive credit for showing attentiveness to the obstacles and the capability of picking their own way through the course when obstacles warrant it, and willingly responding to the rider's cues on more difficult obstacles. Trail exhibitors will be whistled off of course if a score of 0 (Disqualification) takes place. The exhibitor will be expected to exit the course once the whistle is blown.
2. Horse shall be penalized for any unnecessary delay while approaching or negotiating the obstacles. Horses with artificial appearance over obstacles should be penalized.
3. Horses must not be required to work on the rail. The course must be designed, however, to require each horse to show the three gaits (walk, jog and lope) somewhere between obstacles as a part of its work and quality of movement, and cadence should be considered as part of the maneuver score. Gait between obstacles shall be at the discretion of the judge.
4. Open to all horses and ponies. Hands on reins may be changed. No tie-downs or martingales. The class will have no rail work. Horses may be asked to walk, trot (jog, intermediate gait), and canter (lope) between obstacles.
5. Course will be posted at least one hour before the course is open. Contestants may compete any time, but it is the sole responsibility of the contestant to meet the deadlines. No work-offs or finals.
6. Scoring will be on the basis of zero to infinity, with 70 denoting an average performance. Each obstacle will receive an obstacle score that should be added or subtracted from 70, and is subject to a penalty that should be subtracted. Each obstacle will be scored on the following basis, ranging from +1.5 to -1.5: -1.5 extremely poor, -1 very poor, -0.5 poor, zero correct, +0.5 good, +1 very good, +1.5 excellent. Obstacle scores are to be determined and assessed independently of penalty points.
7. **Penalties should be assessed per occurrence as follows:**  
The following deductions will result:
  - **Zero score**
    - Use of more than one finger between reins
    - Use of two hands or changing hands on reins; except for junior horses shown with hackamore or snaffle bit, only one hand may be used on the reins, except that it is permissible to change hands to work an obstacle
    - Use of romal other than as outlined in rules
    - Performing the obstacles incorrectly or other than in specified order
    - No attempt to perform an obstacle
    - Equipment failure that delays completion of pattern
    - Excessively or repeatedly touching the horse on the neck to lower the head
    - Fall to the ground by horse or rider
    - Failure to enter, exit, or work obstacle from correct side or direction, including overturns of more than one-quarter turn
    - Failure to correct line within or between obstacles
    - Failure to work an obstacle in any manner other than how it's described by the course
    - Riding outside designated boundary marker of the arena or course arena
    - Third refusal Failure to demonstrate correct lead or gait, if designated
    - Faults that occur on the line of travel between obstacles (cause for disqualification except in novice amateur or novice youth classes), which shall be faults scored according to severity: head carried too low (tip of ear below the withers consistently); over-flexing or straining neck in head carriage so the nose is carried behind the vertical consistently
  - **1/2 point**
    - Each tick of log, pole, cone or obstacle
  - **1 point**
    - Each hit of or stepping on a log, pole, cone or obstacle
    - Incorrect gait at walk or jog for two strides or less
    - Both front or hind feet in a single-stride slot or space
    - Skipping over or failing to step into required space
    - Split pole in lope-over
    - Failure to meet the correct strides if specified

- **3 points**
  - Break of gait at walk or jog for more than two strides
  - Out of lead or break of gait at lope (except when correcting an incorrect lead)
  - Knocking down an elevated pole, cone, barrel, plant obstacle or severely disturbing an obstacle
  - Stepping outside the confines of, falling or jumping off or out of an obstacle with one foot
  
- **5 points**
  - Dropping slicker or object required to be carried on course.
  - First refusal, balk, or attempting to evade an obstacle by shying or backing more than two strides away.
  - Letting go of gate or dropping rope gate.
  - Use of either hand to instill fear or praise.
  - Stepping outside the confines of, falling or jumping off or out of an obstacle with more than one foot
  - Blatant disobedience (kicking out, bucking, rearing, striking)

When setting courses, management should keep in mind that the idea is not to trap a horse or eliminate it by making an obstacle too difficult. All courses and obstacles are to be constructed with safety in mind to eliminate any accidents. If difficult courses are set, junior trail should be less difficult. When the distances and spaces are measured between all obstacles, the inside base to inside base measurement of each obstacle considering the normal path of the horse should be the measuring point. Enough space must be provided for a horse to jog (at least 30 feet) and lope (at least 50 feet) for the judges to evaluate these gaits.

If disrupted, the course shall be reset after each horse has worked. In the case that a combination of obstacles is used, the course cannot be reset until the contestant finishes the entire course regardless of where any disruption occurs.

At least six obstacles must be used.

### Optional Obstacles

1. Opening, passing through and closing a gate. (Losing control of the gate is to be penalized.) Use a gate which will not endanger the horse or rider. If the gate has a metal, plastic or wooden support bar under the opening, contestants must work the gate moving forward through it.
2. Ride over at least four logs or poles. These can be in a straight line, curved, zigzag or raised. The space between the logs is to be measured, and the path the horse is to take should be the measuring point.

The spacing for walkovers shall be 20 inches to 24 inches and may be elevated to 12 inches. Elevated walkovers should be at least 22 inches apart. The spacing for trot-overs shall be 3 feet to 3½ feet and may be elevated to 8 inches. The spacing for lope-overs shall be 6 feet to 7 feet or increments thereof and may be elevated to 8 inches. Backing obstacles should be spaced at a minimum of 28 inches. If elevated, 30-inch spacing is required. Entrants cannot be asked to back over a stationary object such as a wooden pole or metal bar. Back through and around at least three markers. Back-throughs (L, V, U, straight or similar-shaped course) may be elevated no more than 24 inches.

3. Water hazard (ditch or small pond). No metal or slick-bottom boxes to be used.
4. Serpentine obstacles at walk or jog. Spacing should be a minimum of 6 feet for jog.
5. Carry object from one part of arena to another. (Only objects which might reasonably be carried on a trail ride may be used)
6. Ride over wooden bridge. (Suggested minimum width shall be 36 inches wide and at least six feet long.) Bridge should be sturdy, safe and negotiated at a walk only.
7. Put on and remove a slicker.
8. Remove and replace materials from a mailbox.
9. Side pass (may be elevated to 12 inches maximum).
10. An obstacle consisting of four logs or rails, each 5 feet to 7 feet long, laid in a square. Each contestant will enter the square by riding over log or rail as designated. When all four feet are inside the square, rider should execute a turn, as indicated, and depart.
11. Any other safe and negotiable obstacle which could reasonably be expected to be encountered on a trail ride and meets the approval of the judge may be used.
12. A combination of two or more of any obstacle is acceptable.

### Unacceptable Obstacles:

1. Tires
2. Hides
7. Rocking or moving bridges
8. Water box with floating or moving parts



- |                |  |
|----------------|--|
| 3. Animals     | 9. Flames, dry ice, fire extinguishers, etc.                     |
| 4. PVC pipe    | 10. Logs or poles elevated in a manner that permits such to roll |
| 5. Dismounting | 11. Ground ties  |
| 6. Jumps       |  |

The judge must walk the course and has the right and duty to alter the course in any manner. The judge may remove or change any obstacle he or she deems unsafe or non-negotiable. If at any time a trail obstacle is deemed to be unsafe by the judge, it shall be repaired or removed from the course. If it cannot be repaired and horses have completed the course, the score for that obstacle shall be deducted from all previous works for that class.

### **HUNTER UNDER SADDLE**

1. The class will be judged on the horse's way of going, manners and suitability. Conformation of the horse may only be considered in extremely close competition.
2. Horses enter the ring at a trot and are shown on the flat at a walk, trot and canter while maintaining light contact with the horse's mouth.
3. Horses must work both ways of the ring at all gaits to demonstrate their ability with different leads.
4. The judge may ask finalists to hand gallop, but never more than a safe number of horses to gallop at one time.
5. Horse should back easily and stand quietly. The judge may ask that only the finalist be backed.
6. Large numbers in this class will necessitate elimination heats to accommodate all horses. Finalists from each heat will be called to the center of the arena and be identified.
7. Any portion of a class or heat may be placed on the rail for extra work by the judge at any time.
8. *All contestants are eligible to enter the hunter under saddle class.*

### **HUNT SEAT EQUITATION**

The purpose is to evaluate the ability of the hunter rider to perform various maneuvers on his/her horse which provides a base for natural progression to over fence classes. The communication between horse and rider through subtle cues and aids should not be obvious. Equitation is judged on the rider and his/her effect on the horse. Hunt seat equitation on the flat provides a base for a natural progression to over fence classes. The poll should be level with, or slightly above the withers, to allow proper impulsion behind. The head should not be carried behind the vertical, giving the appearance of intimidation, or be excessively nosed out, giving a resistant appearance.

Pattern. It is mandatory that the judge post the pattern at least one hour prior to commencement of the class. All patterns must include a walk, trot, canter, and back. Horses' gaits are to be ridden with the same cadence and speed as you would find in the rail phase. All ties will be broken at the discretion of the judge.

Basic Position. To mount, take up reins in left hand and place hand on withers. Grasp stirrup leather with right hand and insert left foot in stirrup and mount. To dismount, rider may either step down or slide down. The size of rider must be taken into consideration.

- Hands should be over and in front of horse's withers, knuckles 30 degrees inside the vertical, hands slightly apart and making a straight line from horse's mouth to rider's elbow. Method of holding reins is optional, and bight of reins may fall on either side. However, all reins must be picked up at the same time.
- The eyes should be up and shoulders back.
- Toes should be at an angle best suited to rider's con-formation; heels down, calf of leg in contact with horse.
- Iron should be on the ball of the foot. Iron or stirrup leather may not be connected by string or any other material to the girth.
- Appropriate English attire must be worn. Clothes and person are to be neat and clean. The use of any type of artificial aid or magnetic device will result in a disqualification.

Class Procedure: Exhibitors may be worked individually from the gate, or they may all enter at once, but a working order must be drawn regardless. The entire class, or only the finalists, must work at all three gaits at least one direction of the arena. Rail work can be used to break ties and possibly adjust placings.

- A turn on the forehand to the right is accomplished by moving haunches to the left.
- A forehand turn to the left is accomplished by moving haunches to the right.
- If riders are asked to drop their irons, they can leave them down or cross them over the withers.
- When performing a leg-yield, the horse should move forward and lateral in a diagonal direction with the horse's body straight with a slight flexion of the head in the opposite direction of lateral movement. When a horse yields to the right, the head is slightly (just to see the eye of the horse) to the left. A horse yielding to the left, the head is slightly flexed to the right

Individual works may be comprised of any of the following: Group #1 - Walk, Sitting Trot, Extended Trot, Posting Trot, Canter, Circles, Figure 8, Halt, Back, Sidepass, Address Reins, Demonstrate Change of Diagonal; Group #2 - Serpentine (Trot or Canter), Turn on Haunches or Forehand, Leg-Yield, Flying or Simple Change of Lead (A simple change of lead is performed by breaking to a walk or trot for 1 to 3 strides); or Group #3 - Canter and Hand Gallop in a straight or curved line, Counter-Canter Figure 8, Drop or Pick-up Irons without stopping.

- **THE WALK:** Should be a four-beat gait with the rider in a vertical position with a following hand.
- **THE POSTING TROT:** Figure 8 at trot, demonstrating change of diagonals. At left diagonal, rider should be sitting the saddle when left front leg is on the ground; at right diagonal, rider should be sitting the saddle when right front leg is on the ground; when circling clockwise at a trot, rider should be on left diagonal; when circling counterclockwise, rider should be on right diagonal. The rider should close his/her hip angle to allow his/her torso to follow the horizontal motion of the horse. The upper body should be inclined about 20 degrees in front of the vertical.
- **SITTING TROT AND CANTER:** At the sitting trot, the upper body is only slightly in front of the vertical. At the canter, the body should be positioned slightly more in front of the vertical. As the stride is shortened, the body should be in a slightly more erect position.
- **TWO-POINT POSITION:** The pelvis should be forward, but relaxed, lifting the rider's weight off the horse's back and transferring the weight through the rider's legs. In this position the two points of contact between horse and rider are the rider's legs. Hands should be forward, up the neck, not resting on the neck.
- **HAND GALLOP:** A three-beat, lengthened canter ridden in two-point position. The legs are on the horse's sides while the seat is held out of the saddle. When at the hand gallop, the rider's angulation will vary somewhat as the horse's stride is shortened and lengthened. A good standard at a normal hand gallop should be about 30 degrees in front of the vertical.

**SCORING.** Exhibitors are to be scored from 0 to infinity, with 70 denoting an average performance. Patterns will be divided into 6 to 10 maneuvers, as specified by the judge, and each maneuver will be scored from +3 to -3 with 1/2 point increments acceptable that will be added or subtracted from 70. Maneuver scores should be determined independent of penalties and should reflect equal consideration of both performance of the exhibitor's pattern and the equitation form and effectiveness of the exhibitor to result in the following scores: +3 Excellent, +2 Very Good, +1 Good, 0 Average or Correct, -1 Poor, -2 Very Poor, -3 Extremely Poor. Exhibitors' overall equitation form and effectiveness should also be scored from 0 to 5 with 0 to 2 Average, 3 Good, 4 Very Good, 5 Excellent. Exhibitors should also be judged on the rail, and their pattern score and/or ranking may be adjusted as appropriate.

- **Penalties.** Maneuver evaluations and penalty applications are to be determined independently. The following penalties will be applied for each occurrence and will be deducted from the final score:
  - **Three (3) points.**
    - Break of gait at the walk or trot up to 2 strides.
    - Over or under turn from 1/8 to 1/4 turn.
    - Tick or hit of cone.
    - Missing a diagonal up to 2 strides in the pattern or on the rail.
  - **Five (5) points.**
    - Not performing the specific gait or not stopping within 10 feet (3 meters) of designated location
    - Obviously looking down to check leads or diagonals.
    - Missing a diagonal for more than 2 strides in the pattern or on the rail.
    - Incorrect lead or break of gait at the canter (except when correcting an incorrect lead)
    - Complete loss of contact between rider's hand and the horse's mouth
    - Break of gait at walk or trot for more than 2 strides
    - Loss of iron Head carried too low and/or clearly behind the vertical while the horse is in motion, showing the appearance of intimidation.
  - **Ten (10) points.**
    - Loss of rein
    - Use of either hand to instill fear or praise while on pattern or during rail work.
    - Holding saddle with either hand Spurring or use of the crop in front of girth.
    - Blatant disobedience including kicking, pawing, bucking, and rearing.
  - **Disqualifications (should not be placed).**

- Failure by exhibitor to wear correct number in visible manner.
- Willful abuse of horse or schooling.
- Fall by horse or exhibitor.
- Illegal use of hands on reins.
- Use of prohibited equipment.
- Off pattern, including: knocking over or wrong side of cone or marker; never performing designated gait, lead, or diagonal; over or under turning more than 1/4 turn.

# Ranch Horse Division

**Personal Attire: Same as Western Division**

**Tack and Equipment: See Western Division**

Reruns will be determined at the discretion of the judge.

Safety helmets are optional

## **RANCH RIDING**

The purpose of the ranch riding class is to measure the ability of the horse to be a pleasure to ride while being used as a means of conveyance from performing one ranch ask to another. The horse should reflect the versatility, attitude and movement of a working ranch horse riding outside the confines of an arena. The horse should be well-trained, relaxed, quiet, soft and cadenced at all gaits. The ideal ranch horse will travel with forward movement and demonstrate an obvious lengthening of stride at extended gaits. The horse can be ridden with light contact or on a relatively loose rein without requiring undue restraint, but not shown on a full drape of reins. The overall manners and responsiveness of the ranch riding horse to make timely transitions in a smooth and correct manner, as well as the quality of the movement are of primary considerations. The ideal ranch riding horse should have a natural head carriage at each gait.

- A. Each horse will work individually, performing the required gait maneuvers and minimum of three optional maneuvers. Horses will be scored on the basis of 0 to 100, with 70 denoting an average performance. Each maneuver will receive a score that should be added or subtracted from 70 and is subject to a penalty that should be subtracted. Each maneuver will be scored on the following basis, ranging from plus 1 1/2 to minus 1 1/2.: -1 1/2 extremely poor, -1 very poor, -1/2 poor, 0 correct, +1/2 good, + 1 very good, + 1 1/2 excellent. Maneuver scores are to be determined and assessed independently of penalty points.
- B. The required gait maneuvers will include the walk, trot, and lope both directions: and the extended trot and extended lope at least one direction; as well as stops, and back.
- C. The optional maneuvers may include a side pass, turns of 360 degrees or more, change of lead (simple or flying), walk, trot, or lope over a log(s); or some reasonable combination of maneuvers that would be reasonable for a horse to perform or encounter during ranch work.
- D. One of the suggested patterns may be used, however a judge may utilize a different pattern as long as all required maneuvers and the three (or more) optional maneuvers are included. Should a judge use one of his/her own patterns, it is recommended to not have the stop following an extended lope.
- E. The maneuvers may be arranged in various combinations with final approval by the judge.
- F. There should be an emphasis on forward movement, free-flowing, and ground covering for all gaits. Transitions should be performed where designated, with smoothness and responsiveness.
- G. No time limit.
- H. The use of natural logs is encouraged.
- I. Posting at the extended trot is acceptable.
- J. Touching or holding the saddle horn is acceptable.

## **Ranch Riding Apparel and Equipment**

- A. No hoof polish.
- B. No braided or banded manes or tail extensions.
- C. Trimming inside ears is discouraged.
- D. Trimming bridle path is allowed, also trimming of fetlocks or excessive (long) facial hair.
- E. Equipment with silver should not count over a good working outfit. Silver on bridles and saddles is discouraged.
- F. It is suggested competitors use a breast collar and a rear cinch.

## **Penalties and scoring system.**

A contestant shall be penalized each time the following occur:

### **One (1) point penalties:**

- Too slow/per gait
- Over-bridled
- Out of frame
- Break of gait at walk or trot for 2 strides or less

### **Three (3) point penalties**

- Break of gait at walk or trot for more than 2 strides

- Break of gait at lope
- Wrong lead or out of lead
- Draped reins (per maneuver)
- Out of lead or cross-cantering more than two strides when changing leads
- Trotting more than three strides when making a simple lead change
- Severe disturbance of any obstacle

**Five (5) point penalties**

- Blatant disobedience (kick, bite, buck, rear, etc.) for each refusal

**Placed below horses performing all maneuvers**

- Eliminates maneuver
- Incomplete maneuver

**Zero (0) score**

- Illegal equipment including hoof black, braided or banded manes, or tail extensions
- Willful abuse
- Major disobedience or schooling

No specific penalties will be incurred for nicks/hits on logs but deduction may be made in maneuver score.

No specific penalties will be incurred for over/under spins but deduction may be made in maneuver score.

## RANCH RIDING – PATTERN I

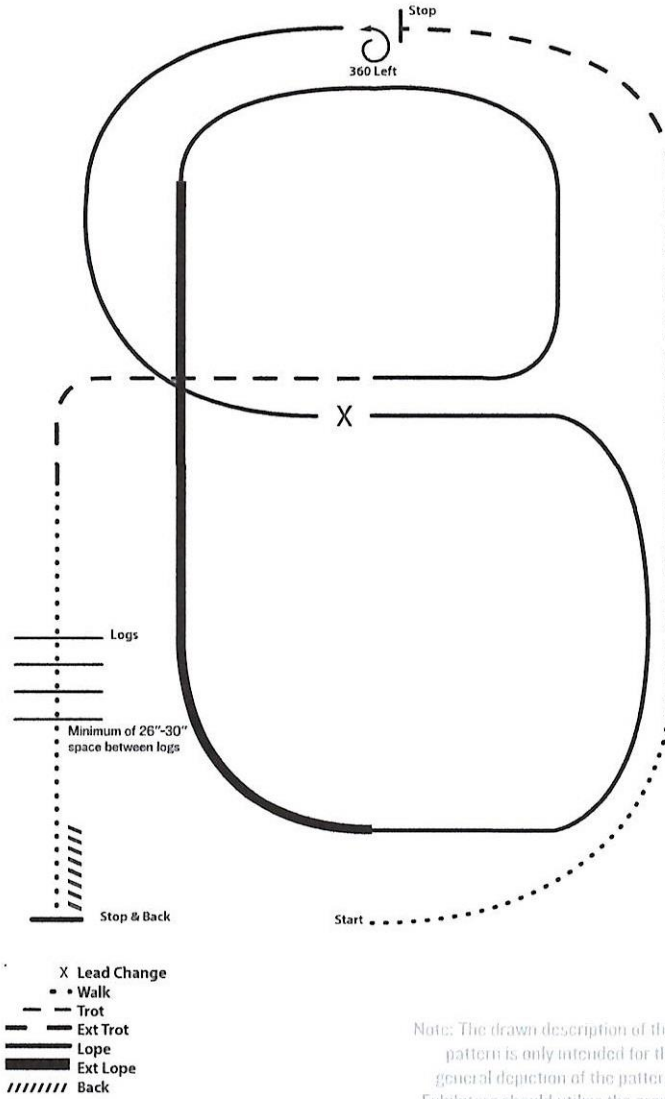

Note: The drawn description of this pattern is only intended for the general depiction of the pattern. Exhibitors should utilize the arena space to best exhibit their horses.

1. Walk
2. Trot
3. Extend the trot, at the top of the arena ,stop
4. 360 degree turn to the left
5. Left lead 1/2 circle, lope to the center
6. Change leads (simple or flying)
7. Right lead 1/2 circle
8. Extended lope up the long side of the arena (right lead)
9. Collect back to a lope around the top of the arena and back to center
10. Break down to an extended trot
11. Walk over logs
12. Stop and back

## RANCH RIDING – PATTERN 2

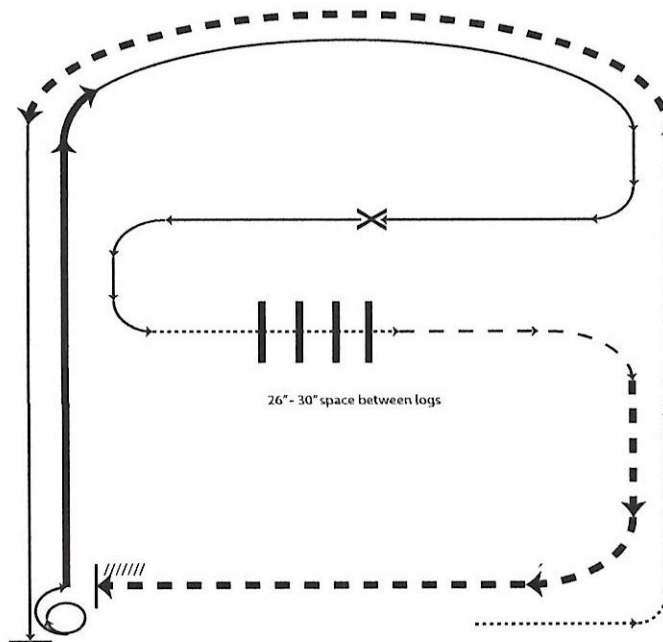

- X Lead Change
- Walk
- - - Trot
- Ext Trot
- Lope
- Ext Lope
- //// Back

1. Walk
2. Trot
3. Extended trot
4. Left lead lope
5. Stop, 1/2 turn right
6. Extended lope
7. Collect to working lope-right lead
8. Change leads (simple or flying)
9. Walk
10. Walk over logs
11. Trot
12. Extended trot
13. Stop and back

Note: The drawn description of this pattern is only intended for the general depiction of the pattern. Exhibitors should utilize the arena space to best exhibit their horses.

**RANCH RIDING – PATTERN 3**

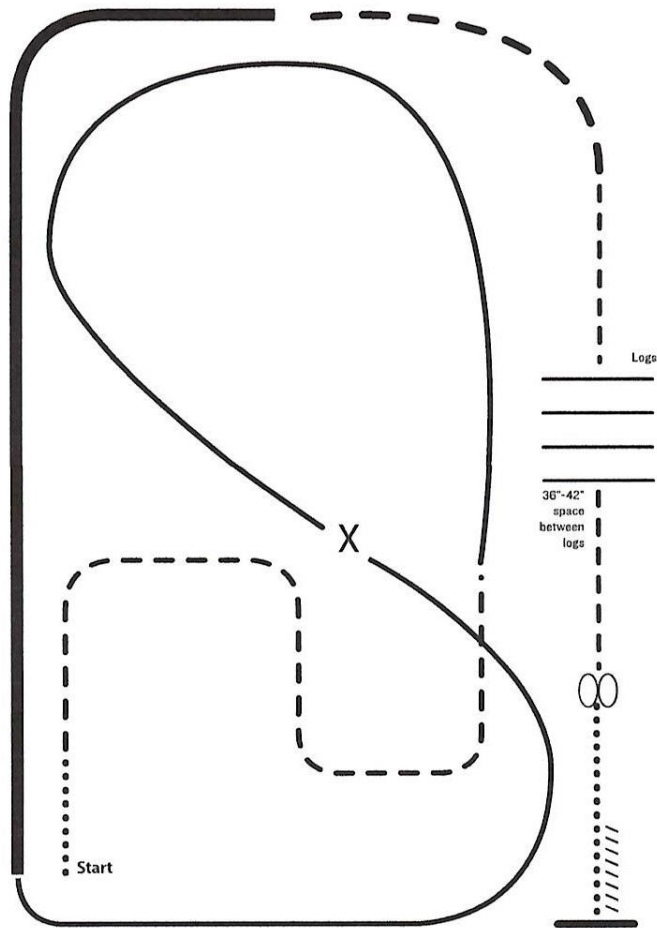

- X Lead Change
- • Walk
- - - Trot
- - - Ext trot
- — — Lope
- — — Ext Lope
- ////// Back

Note: The drawn description of this pattern is only intended for the general depiction of the pattern. Exhibitors should utilize the arena space to best exhibit their horses.

- I. Walk
2. Trot serpentine
3. Lope left lead around the end of the arena and then diagonally across the arena
4. Change leads (simple or flying) and
5. Lope on the right lead around end of the arena
6. Extend lope on the straight away and around corner to the center of the arena
7. Extend trot around corner of the arena
8. Collect to a trot
9. Trot over logs
10. Stop, do 360 degree turn each direction (either direction 1st) (L-R or R-L)
- II. Walk, stop and back



## RANCH RIDING - PATTERN 4

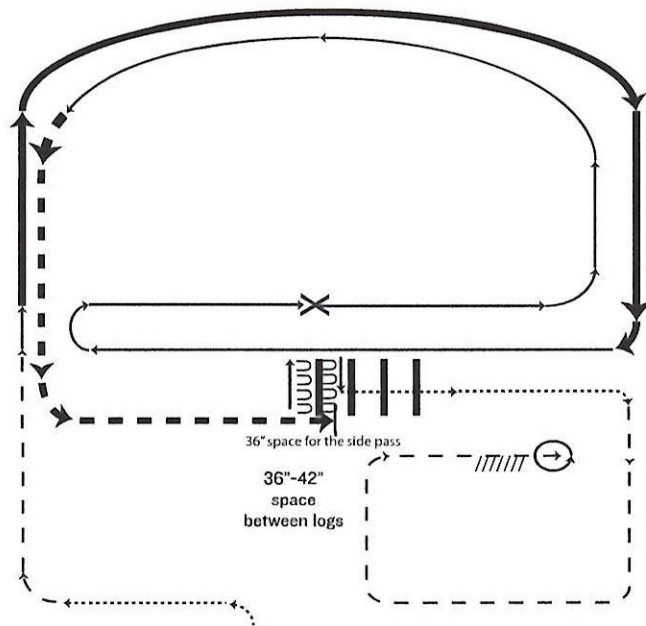

- X Lead Change
- Walk
- - - Trot
- — — Ext Trot
- Lope
- Ext Lope
- /////// Back

- I. Walk
2. Trot
3. Extended lope-right lead
4. Lope-right lead
5. Change leads (simple or flying)
6. Lope left lead
7. Extended trot
8. Stop, side pass left, side pass right, 1/2 way
9. Walk over logs
10. Walk
- II. Trot square
12. Stop, 360° turn left, back

Note: The drawing depicts the pattern as only intended for the general depiction of the pattern. Exhibitors should utilize the arena space to best exhibit their horses.

## RANCH RIDING - PATTERN 5

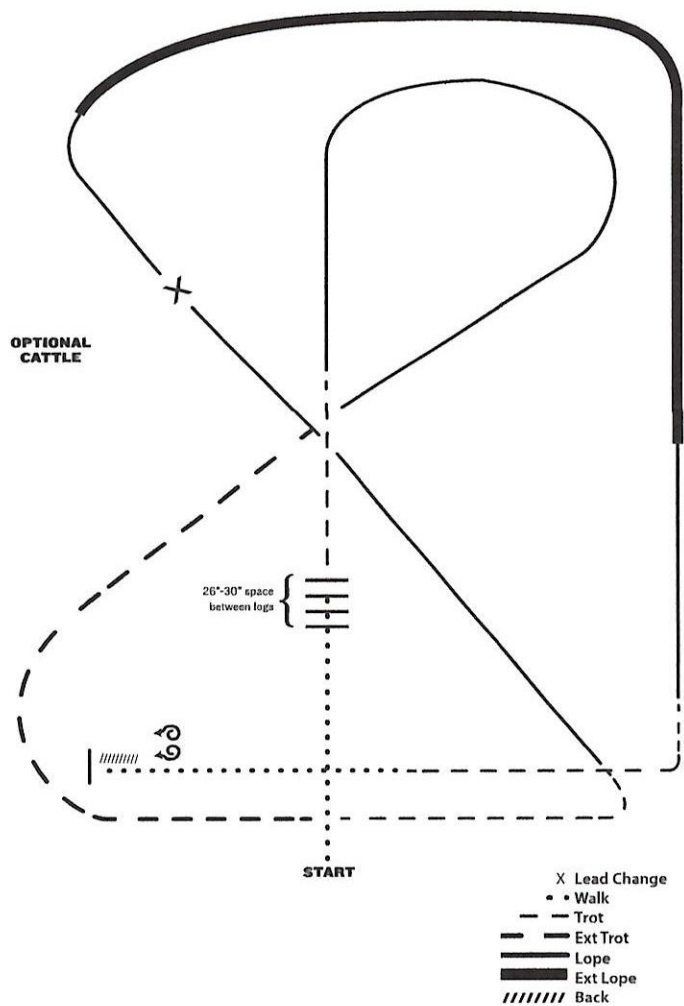

1. Walk
2. Walk over logs
3. Trot
4. Lope right lead
5. Extended trot
6. Trot
7. Lope left lead
8. Change leads (simple or flying)
9. Right lead, extended lope
10. Collect Lope
11. Trot
12. Walk
13. Stop and back
14. 360 degree turn each direction (either direction 1st) (L-R or R-L)

Note: The drawn description of this pattern is only intended for the general depiction of the pattern. Exhibitors should utilize the arena space to best exhibit their horses.

## RANCH RIDING - PATTERN 6

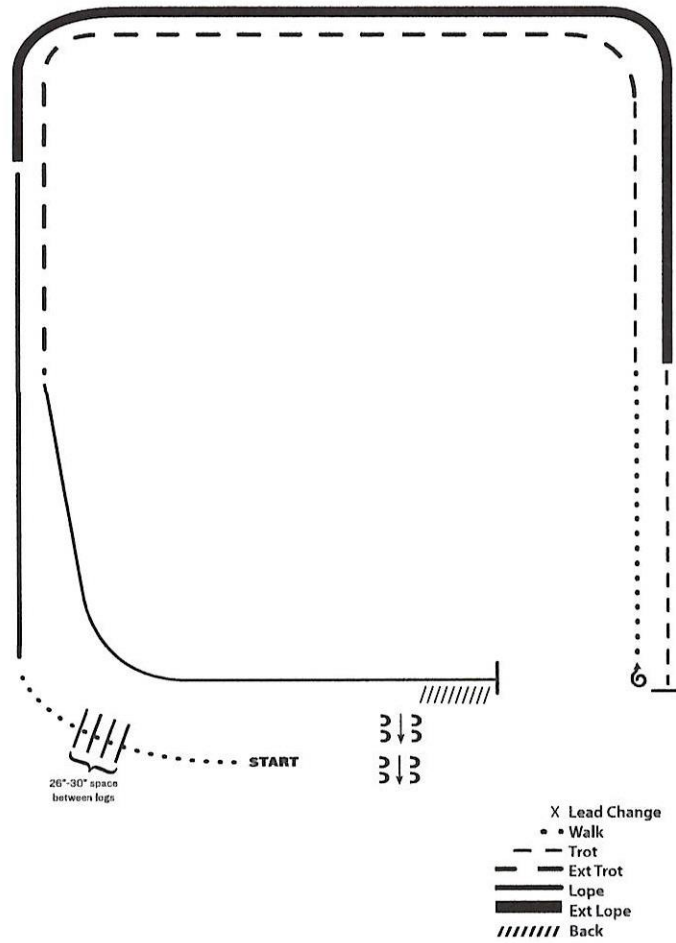

1. Walk
2. Walk over legs
3. Lope right lead
4. Extended lope (right lead)
5. Trot
6. Stop, 1 1/2 turns right
7. Walk
8. Trot
9. Extended trot
10. Lope left lead
11. Stop and Back
12. Side pass right

Note: The drawn description of this pattern is only intended for the general depiction of the pattern. Exhibitors should utilize the arena space to best exhibit their horses.

## RANCH RIDING - PATTERN 7

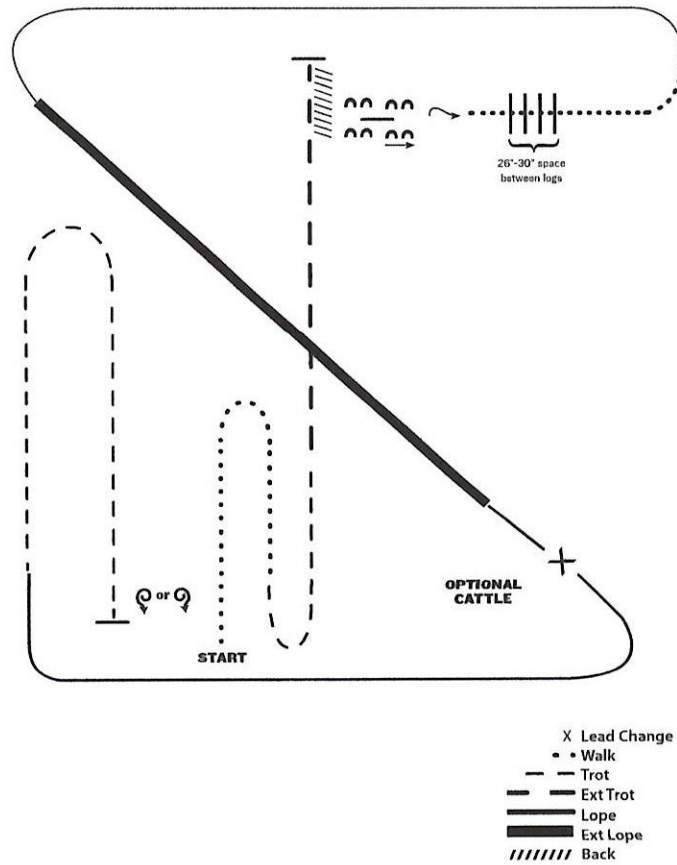

1. Walk
2. Trot
3. Extended trot
4. Stop and back
5. Side pass over log right
6. 1/4 turn right, walk over logs
7. Walk
8. Lope left lead
9. Extended lope (left lead)
10. Collect lope, change leads (simple or flying)
11. Lope right lead
12. Trot
13. Stop, one 360 degree turn either direction

Note: The drawn description of this pattern is only intended for the general depiction of the pattern. Exhibitors should utilize the arena space to best exhibit their horses.

## RANCH RIDING - PATTERN 8

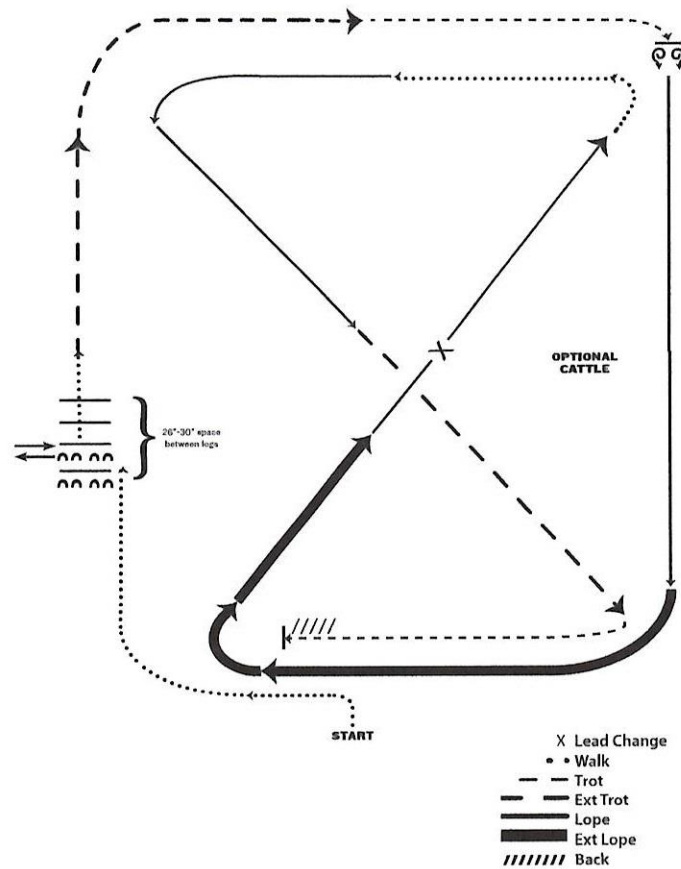

1. Walk
2. Side pass left across first log, side pass 1/2 way to right
3. Walk across logs
4. Extended trot
5. Trot
6. Stop, 360 degree turn each direction (either direction 1st) (L-R or R-L)
7. Lope right lead
8. Extended lope (right lead)
9. Collect lope, change leads (simple or flying)
10. Walk
11. Lope left lead
12. Extended trot
13. Trot
14. Stop and back

Note: The drawn description of this pattern is only intended for the general depiction of the pattern. Exhibitors should utilize the arena space to best exhibit their horses.

## RANCH RIDING - PATTERN 9

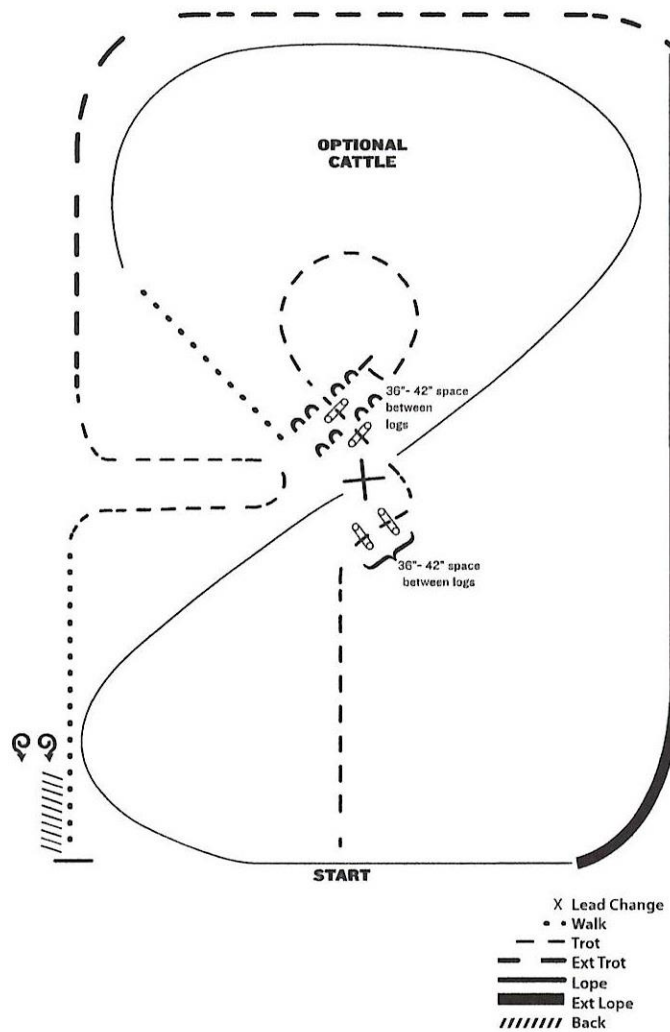

1. Trot
2. Trot two sets of logs
3. Trot circle, stop and side pass log left
4. Walk
5. Lope right lead
6. Change leads (simple or flying)
7. Lope left lead
8. Extended lope (left lead)
9. Extended trot
10. Trot
11. Walk
12. Stop and back
13. 360 degree turn each direction (either direction 1st) (L-R or R-L)

Note: The drawn description of this pattern is only intended for the general depiction of the pattern. Exhibitors should utilize the arena space to best suit their horses.

## RANCH RIDING - PATTERN 10

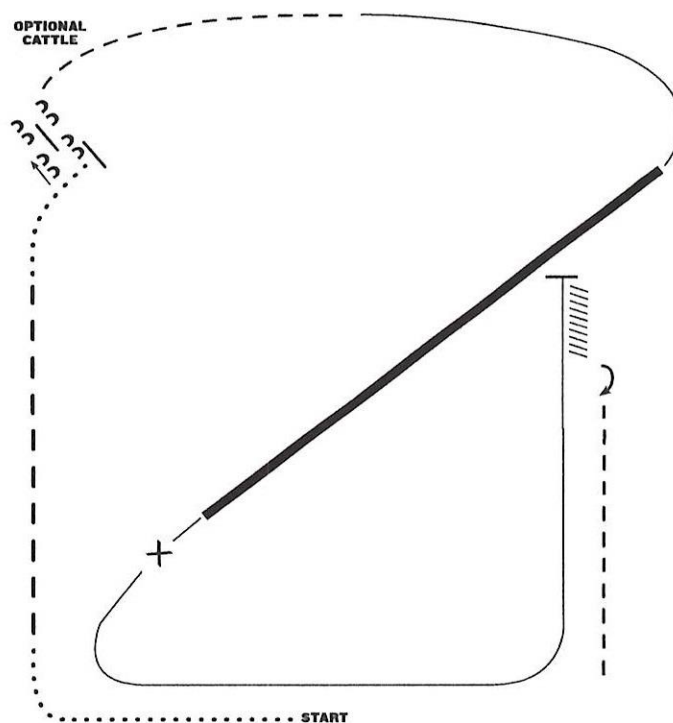

- X Lead Change
- Walk
- - - Trot
- - - - Ext Trot
- Lope
- Ext Lope
- /////// Back

1. Walk
2. Extended trot
3. Walk
4. Stop, side pass log left
5. Trot
6. Lope right lead
7. Extended Lope (right lead)
8. Collect lope and change leads (simple or flying)
9. Lope left lead
10. Stop and back
11. 180 turn to right
12. Trot

Note: The pattern description of this pattern is only intended for the general depiction of the pattern. Exhibitors should utilize the arena space to best exhibit their horses.

## RANCH RIDING - PATTERN 11

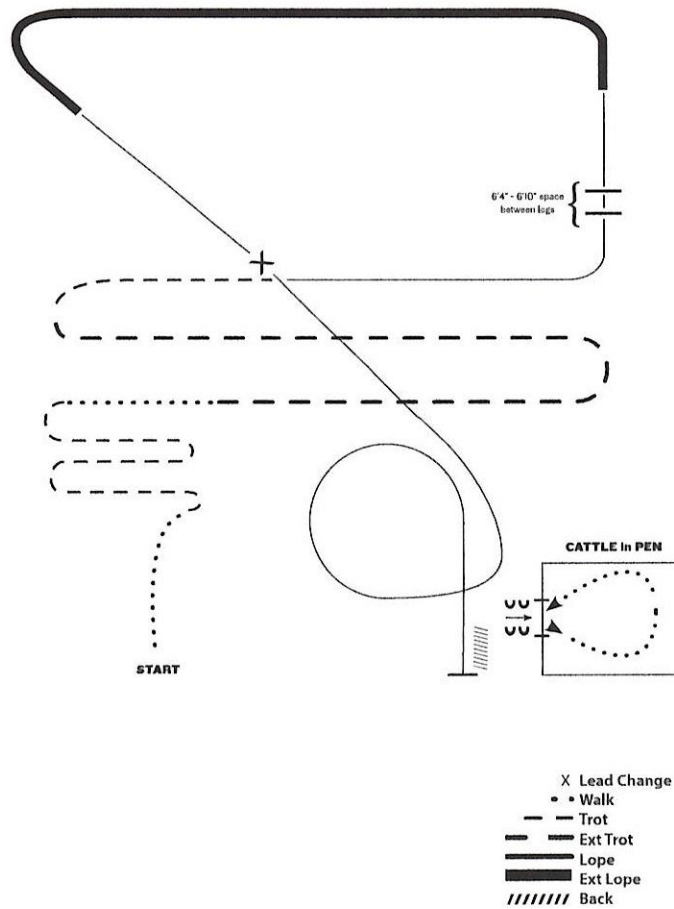

1. Walk
2. Trot serpentine
3. Walk
4. Extended trot
5. Trot
6. Lope left lead
7. Lope over logs
8. Extended lope (left lead)
9. Collect lope, change leads (simple or flying)
10. Lope right lead
11. Lope circle
12. Stop and back
13. Side pass to gate, left hand push into pen
14. Walk through cattle, right hand push out

Note: This diagram description of this pattern is only intended for the general depiction of the pattern. Exhibitors should utilize the arena space to best exhibit their horses.



## RANCH RIDING - PATTERN 12

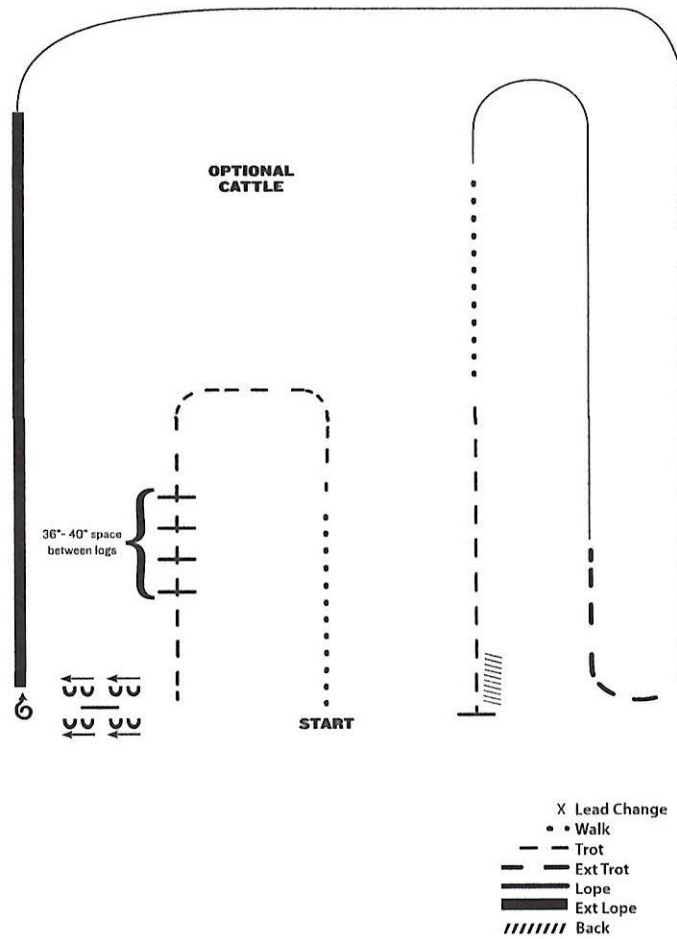

1. Walk
2. Trot
3. Trot logs
4. Side pass right over log
5. 1 1/2 turns right
6. Extended lope (right lead)
7. Lope right lead
8. Extended trot
9. Lope left lead
10. Walk
11. Trot
12. Stop and back

Note: The drawn description of this pattern is only intended for the general depiction of the pattern. Exhibitors should utilize the arena space to best exhibit their horses.

**RANCH RIDING – PATTERN 13**

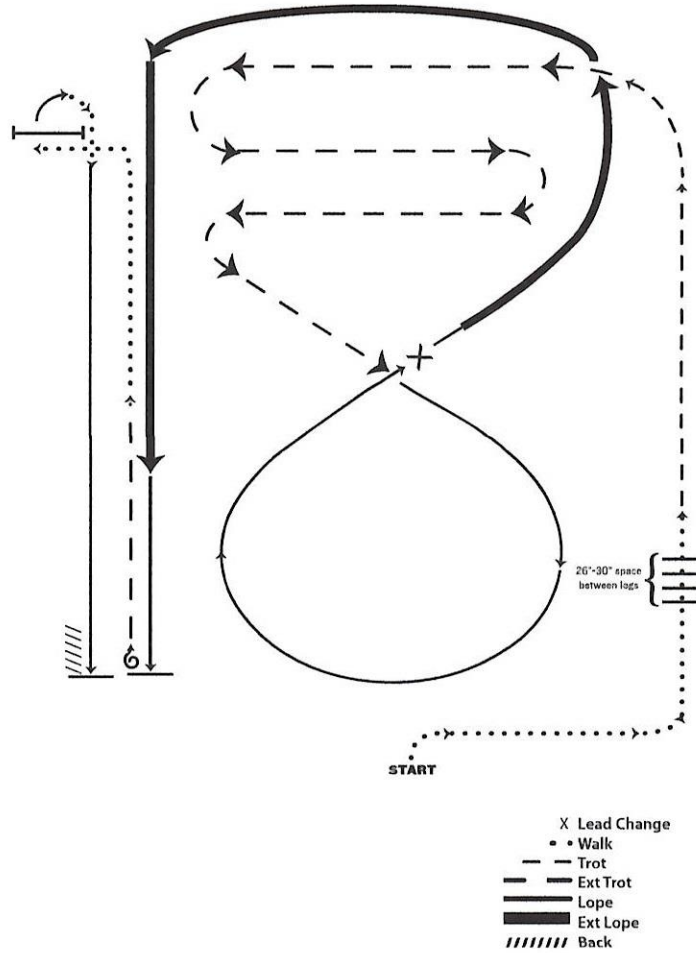

1. Walk
2. Walk over logs
3. Trot
4. Extended trot serpentine
5. Lope right lead
6. Change leads (simple or flying)
7. Extended lope (left lead), collect lope
8. Stop, 1 1/2 turn, either direction
9. Trot
10. Walk to gate
11. Right hand push gate
12. Walk, lope left lead
13. Stop and back

Note: The drawn description of this pattern is only intended for the general depiction of the pattern. Exhibitors should utilize the arena space to best exhibit their horses.

**RANCH RIDING - PATTERN 14**

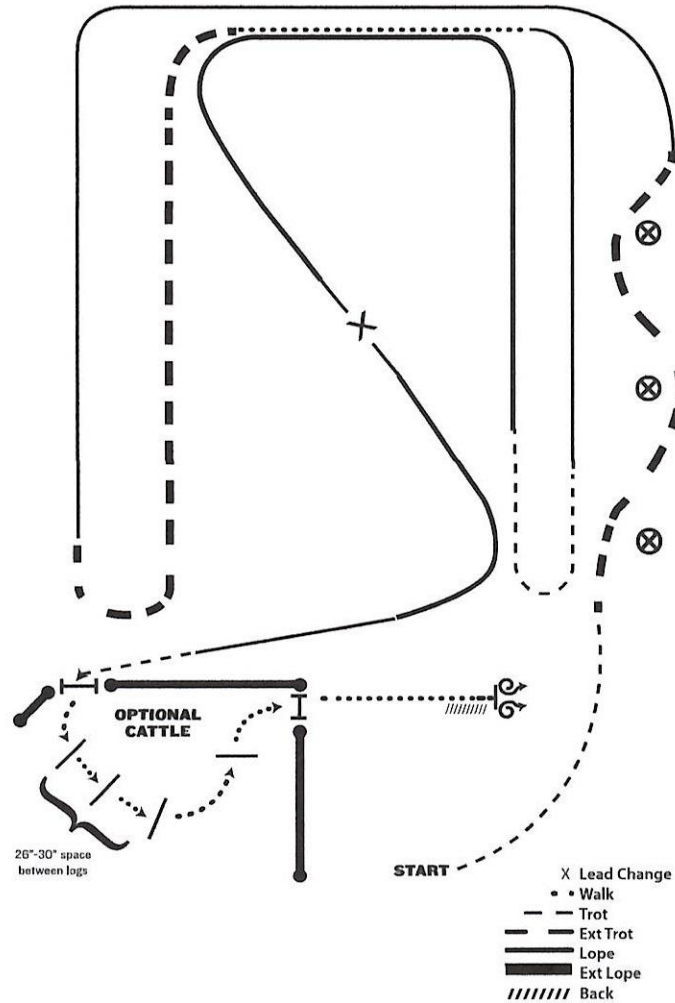

1. Trot
2. Extended trot
3. Lope left lead
4. Extended trot
5. Walk
6. Lope right lead
7. Trot
8. Extended lope (left lead)
9. Collect lope, change leads (simple or flying), extended lope (right lead), collect lope
10. Trot
11. Left hand push gate into pen
12. Walk over logs
13. Right hand push gate out of pen
14. Walk
15. Stop, 360 degree turn each direction (either direction 1st) (L-R or R-L)
16. Back

Note: The drawn description of this pattern is only intended for the general depiction of the pattern. Exhibitors should utilize the arena space to best exhibit their horses.

## RANCH RIDING - PATTERN 15

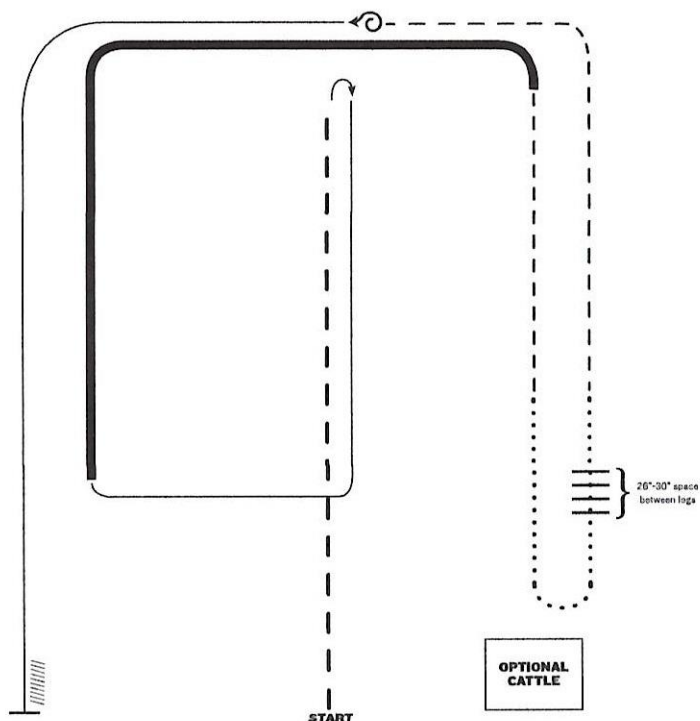

- X Lead Change
- • Walk
- - Trot
- — Ext Trot
- — Lope
- — Ext Lope
- //// Back

1. Extended trot
2. Stop, rollback right
3. Lope right lead
4. Extended lope (right lead)
5. Trot
6. Walk
7. Walk over logs
8. Walk
9. Trot
10. Stop, 360 left
11. Lope left lead
12. Stop and back

Note: The drawn description of this pattern is only intended for the general depiction of the pattern. Exhibitors should utilize the arena space to best exhibit their horses.

## **RANCH RAIL**

This class is intended as a rail class but individuals working off the rail will not be penalized.

The ranch rail pleasure class measures the ability of the horse to be a pleasure to ride while being used as a means of conveyance from one ranch task to another and should reflect the versatility, attitude, and movement of a working horse. The horse should be well-broke, relaxed, quiet, soft and cadenced at all gaits. The horse should be ridden on a relatively loose rein with light contact and without requiring undue restraint. The horse should be responsive to the rider and make timely transitions in a smooth and correct manner. The horse should be soft in the bridle and yield to contact. The ideal ranch rail horse should have a natural head carriage at each gait. In all gaits, movement of the ranch rail pleasure horse should simulate a horse needing to cover long distances, softly and quietly, like that of a working ranch horse. This class should show the horse's ability to work at a forward, working speed while under control by the rider. Light contact should be rewarded and horse shall not be shown on a full drape of reins. The overall manners and responsiveness of the horse while performing the maneuver requirements and the horse's quality of movement are the primary considerations.

The following terminology shall apply:

1. Walk – The walk is a natural, flat footed, four-beat gait. The gait is rhythmic and ground-covering. As in all gaits, the horse should display a level, or slightly above level topline with a bright, attentive expression.
2. Trot – The trot is a natural two-beat gait demonstrating more forward motion than the western jog.
3. Extended Trot – The extended trot is an obvious lengthening of the stride with a definite increase in pace. The horse should be moving in a manner as if it were covering a large area on a ranch with an above level topline.
4. Lope – The lope is a three-beat gait. The lope should be relaxed and smooth with a natural, forward moving stride.
5. Extended Lope – The extended lope is not a run or a race but should be an obvious lengthening of the stride, demonstrating a forward, working speed. The horse should display an above level topline with a bright, attentive expression.

Part of the evaluation of this class is on smoothness of transitions. A horse may be collected from the extended trot as the horse moves into the lope. The transition from the extended lope down to the trot is a transition to the seated trot not the extended trot. Therefore, an extra cue to achieve this gait is expected. Horses that complete this total transition within three strides calmly and obediently should be rewarded. Horses that attempt to stop or do stop prior to trotting will be penalized. Judges expect to see horses that have been trained to respond to cues. To see these cues applied discretely and the horse responding correctly could be a credit earning situation.

**Ranch Rail Pleasure Penalties.** A contestant shall be penalized each time the following occur:

1. Too slow/per gait
2. Over-bridled
3. Out of frame
4. Break of gait at walk or jog for 2 strides or less
5. Break of gait at walk or jog for more than 2 strides
6. Break of gait at lope
7. Wrong lead or out of lead
8. Draped reins
9. Out of lead or cross-cantering more than two strides
10. Trotting more than three strides when taking lead
11. Blatant disobedience (kick, bite, buck, rear, etc.)
12. Major disobedience or schooling
13. Spurring in front of cinch
14. Use of either hand to instill fear/ praise

**Ranch Class Apparel and Equipment:** Attire and tack should be clean and presentable. Working tack is encouraged.

1. Hoof polish is not allowed.
2. No braided or banded manes or tail extensions.
3. Trimming inside ears is discouraged.
4. Trimming bridle path, fetlocks or excessively long facial hair is allowed.
5. Equipment with silver should not count over a good working outfit. Silver bridles and saddles are discouraged.

Only one hand may be used on the reins, except for junior horses shown with an acceptable snaffle bit or hackamore/bosal. Hands must not be changed. Hands to be around reins. One finger between reins permitted when using split reins only. While horse is in motion, hands shall be clear of the horse and saddle except that it is permissible to hold the saddle horn with either hand.

Posting at the extended trot is acceptable.

Class shall work both ways of the ring at all requested gaits.

## **RANCH REINING**

The ranch reining class measures the ability of the ranch horse to perform basic handling maneuvers with a natural head carriage in a forward looking manner. The ideal VRH ranch reining horse should have a natural ranch horse appearance from head to tail in each maneuver. Patterns may be chosen from any of the ranch reining patterns or approved by the show management and judge.

- Credits and Penalties. All runs begin upon entering the pen and any infractions are subject to penalty at that time such as two hands on the reins, using either hand to instill fear or praise, etc.
- To rein a horse is not only to guide him but also to control his movement. The best reined horse should be willingly guided or controlled with little or no apparent resistance. All deviations from the exact written pattern must be considered a lack of or temporary loss of control and therefore a fault that must be marked down according to severity of deviation. The horse/rider team's overall performance should be credited for smoothness, finesse, attitude, quickness and authority of performing various maneuvers while using controlled speed which raises the degree of difficulty and makes the horse/rider team more exciting a pleasing to watch.

### **Scoring Ranch Horse Reining**

#### **Credits:**

- + Overall smoothness of pattern
- + Degree of difficulty exhibited by stops, spins and rollbacks and speed in circles and run-outs.
- + Horse should guide willingly without undue resistance.
- + Lack of set-ups or anticipations in the execution of any of the maneuvers.
- + Exhibiting finesse, attitude, quickness, authority and controlled speed while completing a correct maneuver

#### **Deductions:** *to be subtracted from maneuver scores are as follows:*

**Disqualification (DQ):** Lameness; abuse; illegal equipment; disrespect or misconduct; leaving arena before pattern is complete; improper western attire; fall of horse/rider.

**Off-Pattern (OP):** breaking pattern; inclusion of maneuver (e.g. over or under-spinning, backing more than two (2) strides, etc.); trotting in excess of 1/2 circle or 1/2 length of the arena; repeated blatant disobedience; use of two hands (except junior horses shown in a snaffle bit/hackamore), more than one finger between split reins or any fingers between romal reins (except in the two-rein). Exhibitors cannot place above others who complete the pattern correctly.

**10 point Deduction:** Unnatural ranch horse appearance (Horse's tail is obvious and consistently carried in an unnatural manner in every maneuver) - -

#### **Five Point Deductions:**

1. Blatant disobediences, including kicking, bucking or rearing.
2. Spurring in front in cinch or
3. The use of either hand to instill fear or praise.

#### **Two Point Deductions:**

1. Break of Gait
2. Freeze up in spins or rollbacks. A freeze up is any time the lateral movement of horse's shoulders is completely stopped and has to be restarted to complete the maneuver.
3. In trot in patterns, failure to stop or walk before executing a canter departure.
4. In run in patterns, failure to be at a canter before first marker
5. Failure to completely pass a specified marker before initiating a stop.
6. Over or under spinning of more than one-fourth turn.
7. Jogging more than two strides to start circles or exit rollbacks.

#### **One point Deduction:**

1. Each time a horse is out of lead. Penalties are cumulative for each occurrence and each one-fourth circle.
2. Overbridled.
3. Over or under spinning up to 1/4 turn.

#### **One-half point Deduction:**

1. Jogging less than two strides to start circles or exit rollbacks.
2. Failure to maintain a minimum of twenty feet from wall or fence for stops or rollbacks on standard patterns except for Novice & Youth Pattern # 1.
3. For one stride delayed lead change.
4. Over or under spinning up to 1/8 turn.

# Ranch Reining Pattern 1

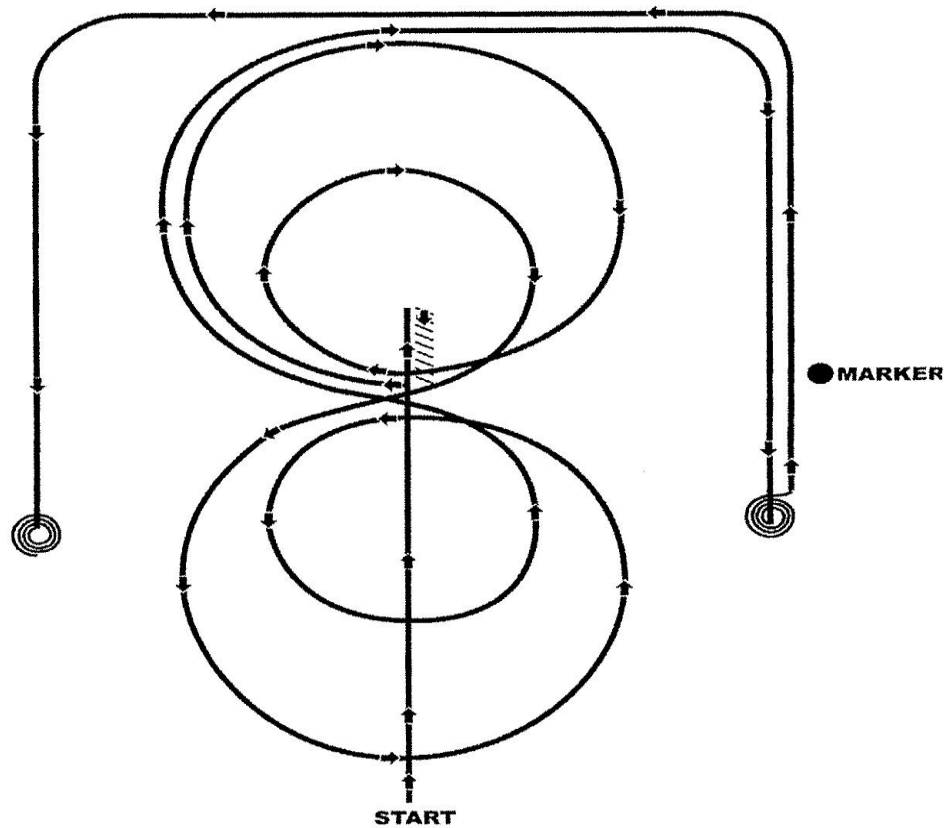

- 1.** Start at end of arena. Run down middle past center marker to a sliding stop.
- 2.** Back at least 10 feet to center. 1/4 turn to left.
- 3.** Pick up right lead, large fast circle, small slow circle.
- 4.** Change leads to left, large fast circle, small slow circle.
- 5.** Change leads to right, do not close this circle.
- 6.** Run around end of arena and down the side (approximately 20 feet from fence) past center marker and come to a sliding stop.
- 7.** Complete 3 1/2 spins to the right.
- 8.** Continue back down side and end of arena to other side (approximately 20 feet from fence) go past center marker and come to a sliding stop.
- 9.** Complete 3 1/2 spins to the left.
- 10.** Hesitate to complete pattern.

## Pattern I

- 1.** Stop and back up and 1/4 turn
- 2.** Right circles
- 3.** Left circles
- 4.** Stop
- 5.** 3 1/2 right spins
- 6.** Stop
- 7.** 3 1/2 left spins

# Ranch Reining Pattern 2

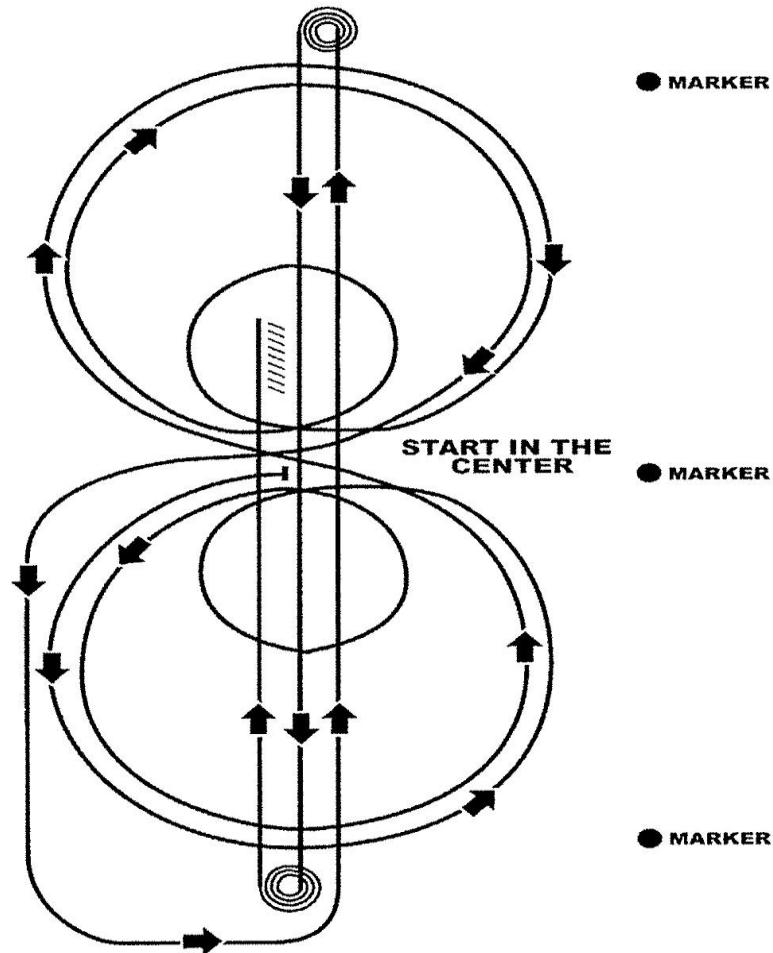

## Mandatory Marker Along Fence or Wall

Trot to center of arena and stop. Start pattern facing toward judge.

1. Pick up left lead, complete three circles to the left. The first one large and fast, the second small and slow, the third large and fast.
2. Change leads at center of arena.
3. Complete three circles to the right. The first one large and fast, the second small and slow, the third large and fast.
4. Change leads at center of arena.
5. Do not stop, continue on to run downs.
6. Run to far end past the marker to a sliding stop. Hesitate
7. Complete 3 1/2 spins to the left. Hesitate.
8. Run to far end past the marker to a sliding stop. Hesitate
9. Complete 3 1/2 spins to the right. Hesitate.
10. Run past center marker to a sliding stop. Hesitate.
11. Back at least 10 feet in a straight line. Hesitate
12. Hesitate to complete pattern.

## Pattern 2

1. Left circles
2. Right circles
3. Stop
4. 3 1/2 left spins
5. Stop
6. 3 1/2 right spins
7. Stop and back up



# Ranch Reining Pattern 3

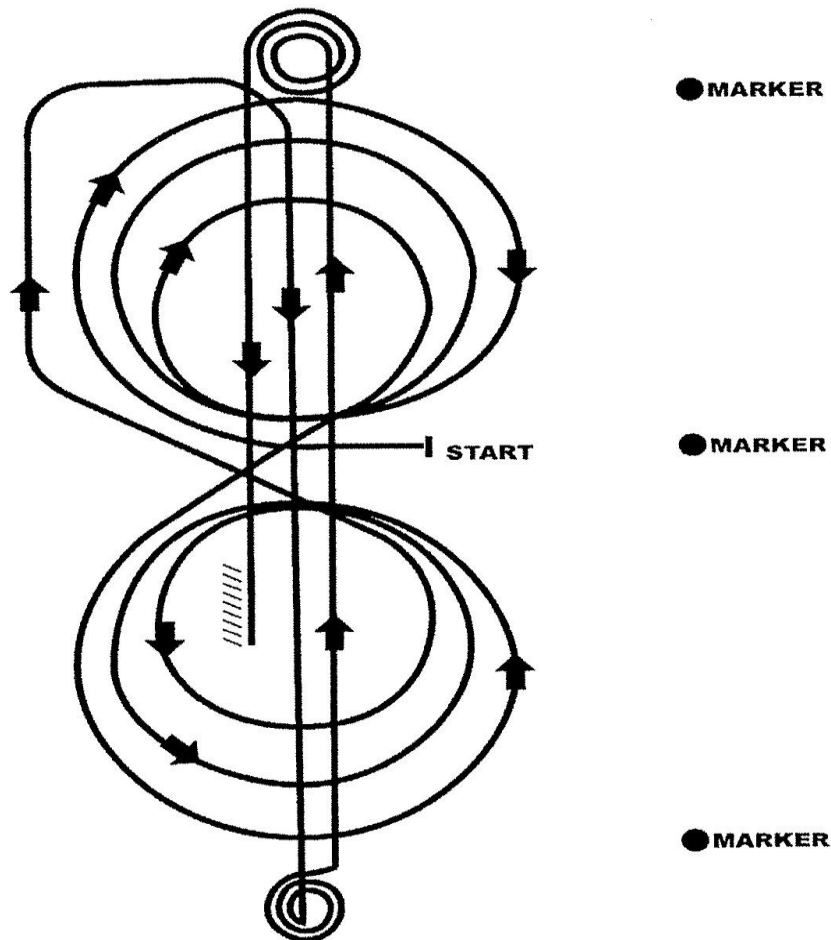

## Mandatory Marker Along Fence or Wall

Trot to center of arena and stop. Start pattern facing toward judge.

1. Begin on right lead and complete three circles to right, two large fast circles followed by one small slow circle, change to left lead.
2. Complete three circles to left, two large, fast circles followed by one small slow circle. Change to right lead.
3. Continue loping around end of arena without breaking gait.
4. Run up center of arena to far end past the end marker and come to a sliding stop.
5. Complete 3 1/2 spins to the right.
6. Run up center of arena past the end marker, come to a sliding stop.
7. Complete 3 1/2 spins to the left.
8. Run back to middle of the arena past the center marker and come to a sliding stop.
9. Back at least 10 feet in a straight line.
10. Hesitate to complete pattern.

## Pattern 3

1. Right circles
2. Left circles
3. Stop
4. 3 1/2 right spins
5. Stop
6. 3 1/2 left spins
7. Stop and back up

# Ranch Reining Pattern 4

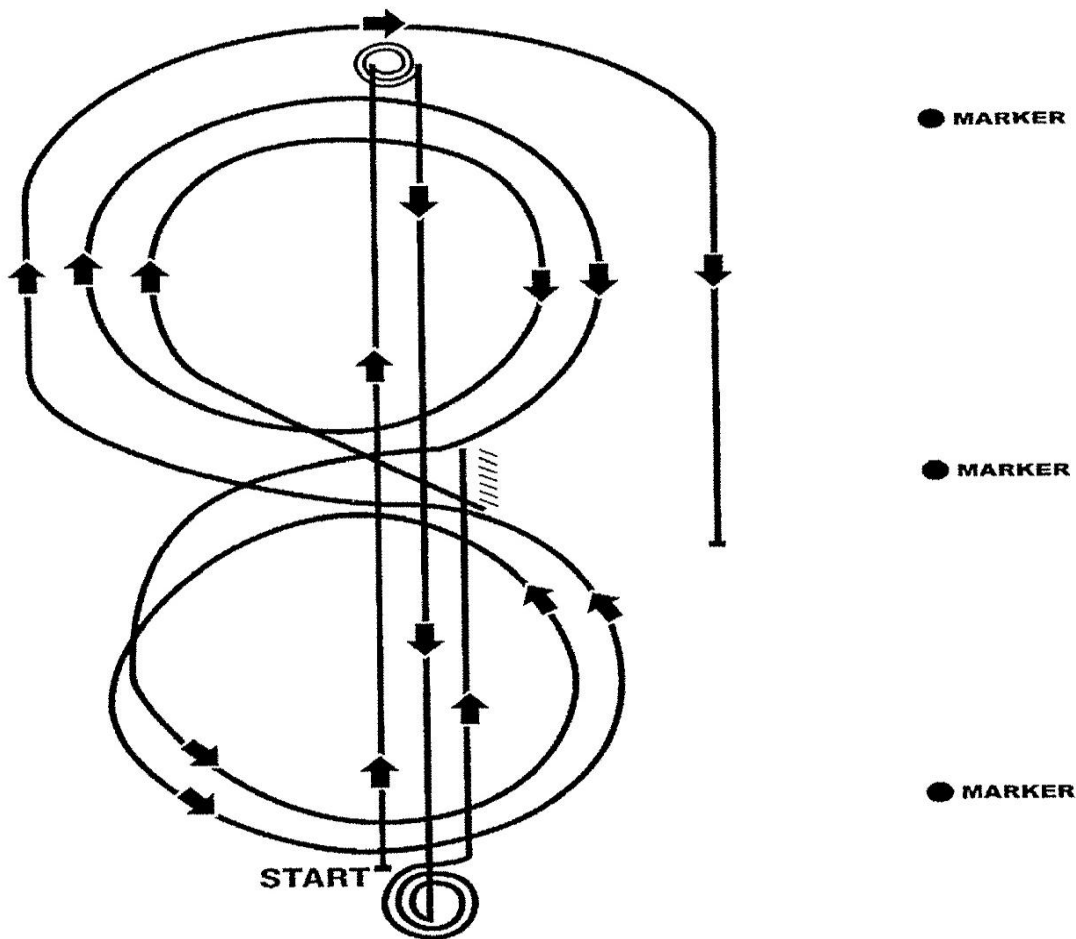

1. Start at end of arena.
2. Run up center of arena past the end marker and come to a sliding stop. Complete 3 1/2 spins to the left.
3. Run to other end of arena past the end marker and stop. Complete 3 1/2 spins to the right.
4. Run past the center marker and stop.
5. Back at least 10 feet in a straight line.
6. Complete 1/4 turn to the left, hesitate. Begin on right lead. Circle to the right. Complete two circles to the right, the first one small and slow and the second large and fast. Change leads at the center of the arena.
7. Complete one small, slow circle and one large, fast circle. Change leads to the right.
8. Run around end of arena to the other side, past the center marker, at least 20 feet from fence and come to a sliding stop.
9. Hesitate to complete pattern.

## Pattern 4

1. Stop
2. 3 1/2 left spins
3. Stop
4. 3 1/2 right spins
5. Stop and back up and 1/4 turn
6. Right circles and left circles
7. Stop

# Ranch Reining Pattern 5

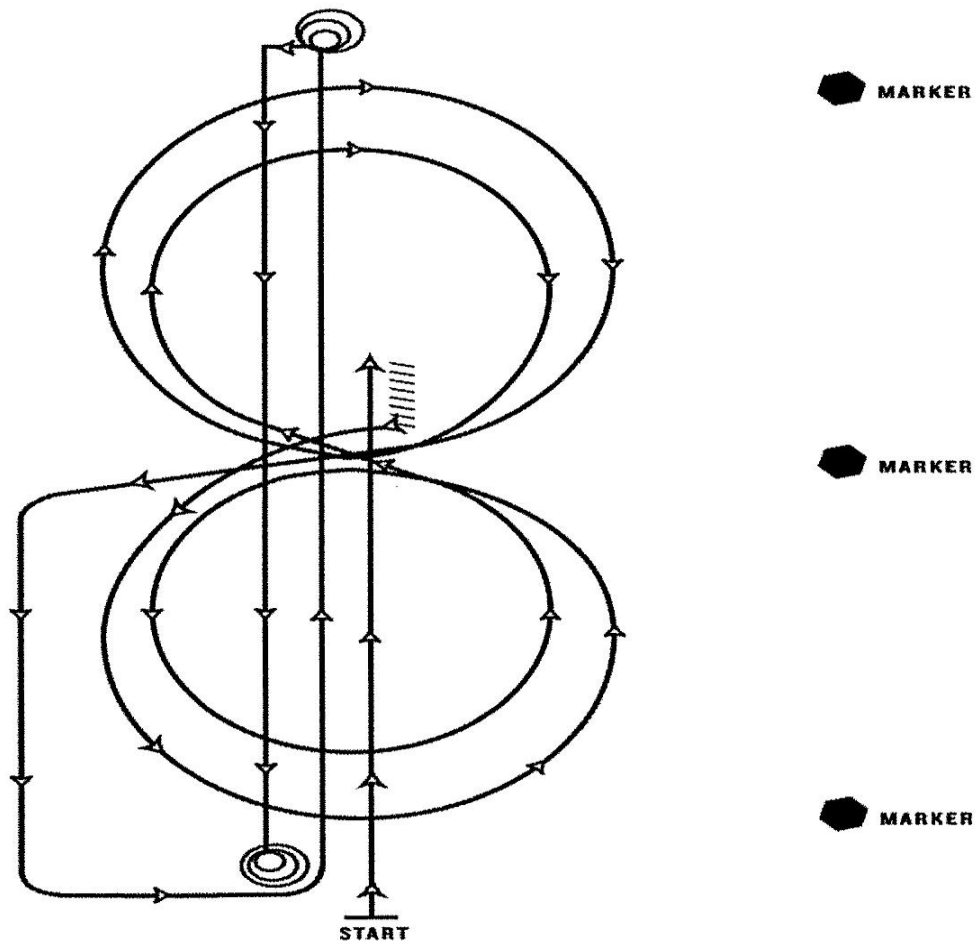

This pattern works best when the exhibitor and cattle enter from the same end of arena.

1. Start at end of arena.
2. Run past the center marker and stop.
3. Back up at least 10 feet.
4. Complete 1/4 turn to the left.
5. Complete 2 circles to the left, the first one large and fast and the second small and slow. Change leads at the center of the arena.
6. Complete two circles to the right, the first one small and slow, the second large and fast. Change leads at the center of the arena.
7. Continue around end of arena without breaking gait or changing leads, run down center of arena past end marker, come to a square sliding stop.
8. Complete 3 1/2 spins to the right.
9. Run down center of arena past end marker and come to a square sliding stop.
10. Complete 3 1/2 spins to the left.
11. Hesitate to complete pattern.

## Pattern 5

1. Stop and back up and 1/4 turn
2. Left circles
3. Right circles
4. Stop
5. 3 1/2 right spins
6. Stop
7. 3 1/2 left spins

# Ranch Reining Pattern 6

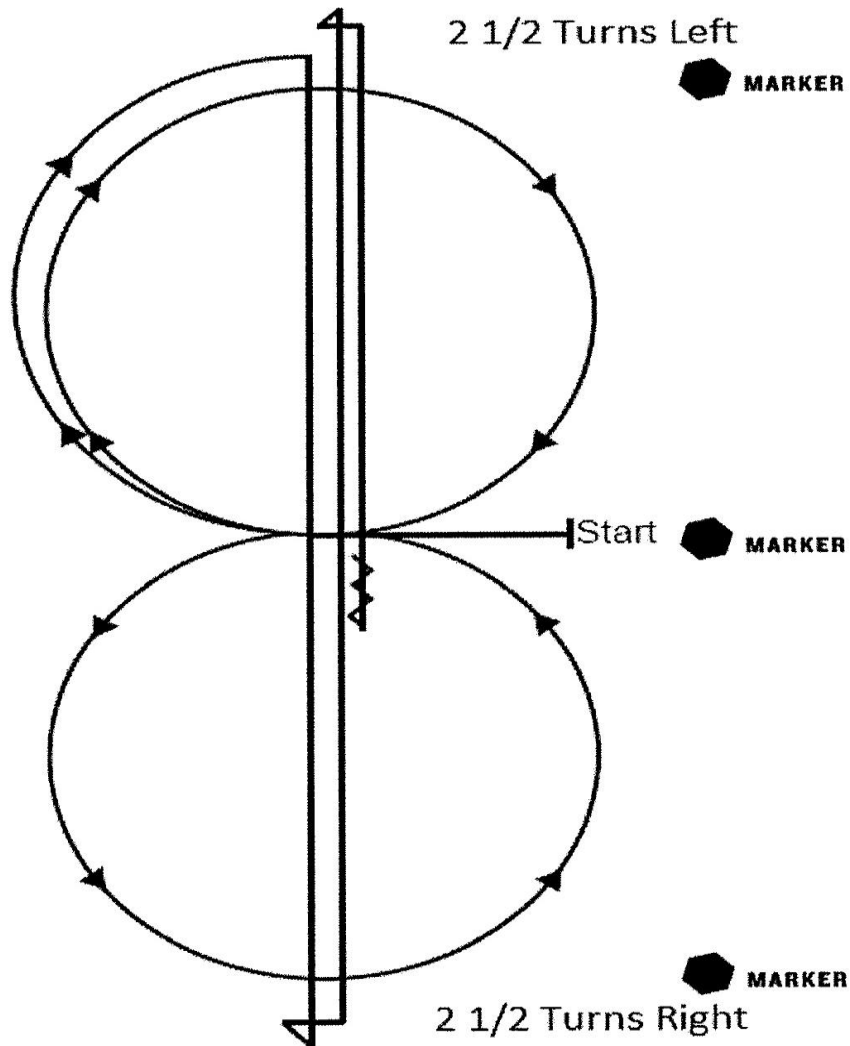

Trot to center of arena, stop. Start pattern facing towards judge

1. Beginning on the right lead lope one circle to the right. Change leads to the left.
2. Complete one circle to the left. Change leads to the right and go to the top of the arena.
3. Run down center of arena past the end marker and come to a sliding stop.
4. Complete 2 1/2 spins to the right.
5. Run to the other end of the arena, past the end marker and come to a sliding stop.
6. Complete 2 1/2 spins to the left.
7. Run past the center marker, stop, back at least 10 feet.

## Pattern 6

1. Right circle
2. Left circle
3. Stop
4. 2 1/2 right spins
5. Stop
6. 2 1/2 left spins
7. Stop and back up

Hesitate to complete pattern

# Ranch Reining Pattern 7

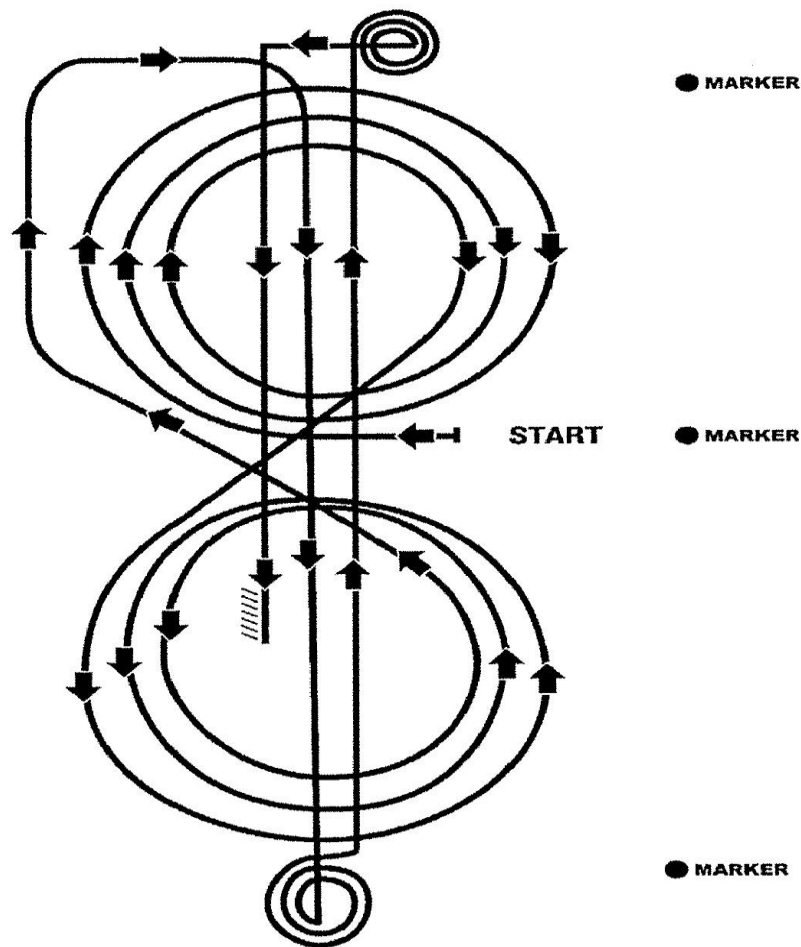

Trot to center of arena and stop. Start pattern facing toward judge.

1. Begin at center of arena. Pick up right lead and complete three circles, the first large, fast, the second small, slow, the third large, fast. Change leads to the left.
2. Complete three circles: the first large and fast; the second small and slow; the third large and fast. Change leads to the right.
3. Continue loping around end of arena without breaking gait or changing leads.
4. Run down center of arena, past end marker and come to a sliding stop. Hesitate.
5. Complete 3 1/2 spins to the right.
6. Run down center of arena past end marker and come to a sliding stop. Hesitate.
7. Complete 3 1/2 spins to the left.
8. Run past center marker and come to a sliding stop.
9. Back up at least 10 feet.
10. Hesitate to complete pattern.

## Pattern 7

1. Right circles
2. Left circles
3. Stop
4. 3 1/2 right spins
5. Stop
6. 3 1/2 left spins
7. Stop and back up

## **RANCH ROPING**

The idea of this class is to show the ability of the horse and rider's skill in handling cattle as if they were doctoring injured or sick cattle. Cattle should be handled as calmly and slowly as possible. The judge should judge this class as if the cattle belonged to him or her. Entry does not have to separate the cow from herd and should not receive credit for separation from herd. If the cow is separated from the herd, there should be no excessive running or cutting of the cow. Roping reins may be used in this class.

1. This is a judged event with a 2-minute time limit. There shall be a 30 second warning given prior to the end of the run. The rope must be thrown, and the contestant may rebuild and throw an unlimited number of loops. No credit will be given for additional loops after a successful catch of any part of the animal. The honda on the rope used must be of a breakaway design.
2. The arena for this event may be shortened with the addition of portable panels. The exhibition area should be the normal width of the arena (usually 100 to 150') by 60' – 75'. Horse and rider must start from an entrance gate which will be opposite from where ten (10) calves/yearlings are held as a herd with each bearing a number 0 - 9. A random draw will be used to select the calf to be roped, which will be announced to the contestant when the horse enters the arena gate.
3. The show committee will provide herd holders. The sole duty of the herd holders is to settle the cattle between runs.
4. The contestant must make a legal catch (both horns, half head or around the neck) of the designated calf and dally up. When the calf breaks free from the honda, the Flag Judge will signal the end of the run.
5. Scoring will be on the basis of 0 to 100, with 70 denoting an average performance.
6. Each maneuver will be scored from a plus three to minus three in ½ point increments.
  - a. Ability to sort
  - b. Rating
  - c. Stopping
  - d. Ability to rope out of the herd without disturbing other cattle
  - e. Dallying
7. Penalties
  - A. Ten (10) point penalty
    - (1) Roping any portion of the cow other than the head/neck.
  - B. Five (5) point penalty
    - (1) Multiple loop run (penalty may be assessed for each rebuild with a maximum of 15 points taken)
    - (2) Loss of cow (re-cut in the herd)
    - (3) Excessive running/scattering of the herd
    - (4) Blatant disobedience including kicking, biting, rearing or striking
  - C. Three (3) point penalty
    - (1) Holding cut too long without roping
  - D. One (1) point penalty
    - (1) Loss of working advantage
  - E. Zero (0) score / DQ
    - (1) Running into or over cattle
    - (2) Schooling
    - (3) Whipping or hitting horse with rope

- (4) Thrown from horse
- (5) Fall to ground
- (6) Loss of rope
- (7) Bucking
- (8) Roping wrong cow
- (9) Roping more than 1 cow with the same loop
- (10) Failure to make legal catch/No catch

## **RANCH BOXING**

The goal of this class is to introduce the rider to the “boxing” phase of the cow work. There is no pattern work prior to the cow work. Judging begins when the contestant enters the arena. There shall be no schooling between cows if a new cow is awarded. The penalty for this is -0-. Each contestant upon receiving a cow in the arena, shall hold that cow on the prescribed end of the arena for 50 seconds, demonstrating the ability of the horse and rider to control the cow. It is legal to hold the reins and romal in one hand (rein hand) while boxing the cow. Time shall begin when the gate closes behind the cow after being let into the arena. The announcer or judge will signal the completion of the 50 seconds with a whistle or horn.

### **SCORING.**

Scoring will be on the basis of 60-80, with 70 denoting an average performance. The judge may blow the whistle at any time to terminate the work. A score of zero will be given if the work is not complete at that time. Each work will be limited to 50 seconds and, the judge may request additional work at his/her option.

### **CREDITS.**

- Maintaining control of the cow at all times
- Maintaining proper position
- Degree of difficulty
- Eye appeal
- Time worked

### **PENALTIES.**

#### **One (1) point**

- Loss of working advantage
- Working out of position

#### **Three (3) points**

- Loss of control and cow leaves end of arena

#### **Five (5) points**

- Spurring or hitting in front of cinch at anytime
- Excessively whipping or spurring the horse
- Blatant disobedience defined as kicking, biting, bucking, rearing, striking or obviously insubordinate

#### **Score - 0**

- Turn tail
- Using two hands on the reins in a bridle or the two-rein
- Fingers between the reins in a bridle class, except in the two-rein
- Balking
- Out of control
- Bloody mouth (inside)
- Illegal equipment
- Leaving working area before pattern is complete
- Fall of horse or rider
- Schooling between rein work and cow work
- Schooling between cows, if new cow is awarded
- Failure to quit working a cow after a new cow has been awarded.

## **RANCH TRAIL**

This class will be judged on the performance of the horse over obstacles with emphasis on manners, response to the rider and quality of movement. Credit will be given to horses negotiating the obstacles with style and some degree of speed, providing correctness is not sacrificed. Horses should receive credit for showing attentiveness to the obstacles and the capability of picking their own way through the course when obstacles warrant it, and willingly responding to the rider's cues on more difficult obstacles.

- A. When setting up trail course, management should keep in mind that the idea is not to trap a horse, or eliminate it by making obstacles too difficult. All courses and obstacles are to be constructed with safety in mind in order to eliminate any accidents.
- B. Horses shall be penalized for any unnecessary delay while approaching or negotiating the obstacles. Horses with artificial appearance over obstacles should be penalized.
- C. Horses must not be required to work on the rail. The course must be designed, however, to require each horse to show the three gaits (walk, jog, and lope) somewhere between obstacles as part of its work, and the quality of movement and cadence should be considered as part of the maneuver score. While on the line of travel between obstacles, the horse shall be balanced, carrying his head and neck in a relaxed, natural position. The head should not be carried behind the vertical, giving the appearance of intimidation, or be excessively nosed out, giving the appearance of resistance. Gaits between obstacles shall be at the discretion of the judge.
- D. The course to be used must be posted at least one hour before the scheduled starting time of the class.
- E. The judge should walk the course and has the right and duty to alter the course in any manner. The judge may remove or change any obstacle he deems unsafe or non-negotiable. If at any time a trail obstacle is deemed unsafe by the judge, it shall be repaired or removed from the course. If it cannot be repaired and horses have completed the course, the score for that obstacle shall be deducted from all previous works for that class.
- F. If disrupted, the course shall be reset. In the case that an obstacle is used in combination, the obstacle cannot be reset until the contestant finishes the entire course.
- G. Scoring will be on the basis of 0-infinity, with 70 denoting an average performance. Each obstacle will receive an obstacle score that should be added or subtracted from 70 and each obstacle is subject to a penalty that should be subtracted.
- H. Each obstacle will be scored on the following basis, ranging from plus (+) 1½ to minus (-) 1½ : -1½ = extremely poor; -1 = very poor; -½ = poor; 0 = correct; +½ = good; +1 = very good; +1½ = excellent.
- I. Obstacle scores are to be determined and assessed independently of penalty points. Penalties should be assessed per occurrence as follows:

### **1 Point Penalty**

- a. Each hit of or stepping on log, pole, cone or obstacle.
- b. Incorrect break gait at walk or jog for two strides or less.
- c. Both front or hind feet in a single-strided slot or space at walk or jog.
- d. Skipping over or failing to step into required space.
- e. Split pole on lope over.
- f. Incorrect number of strides, if specified.

### **3 Point Penalty**

- a. Incorrect or break of gait at walk or jog for more than two strides.
- b. Out of lead or break of gait at lope (except when correcting an incorrect lead).
- c. Knocking down an elevated pole, cone, barrel, plant, obstacle or severely disturbing an obstacle.
- d. Fall or jumping off or out of bridge or water box with one foot once the horse has gotten onto or into that obstacle.
- e. Stepping outside the confines of an obstacle with designated boundaries (ie: back through. 360 box, side pass) with one foot once the horse has entered the obstacle.
- f. Missing or evading pole that is part of a series of an obstacle.

### **5 point Penalty**

- a. Dropping object required to be carried on course.
- b. First and second cumulative refusal, balk or attempting to evade an obstacle. A Refusal is addressing an obstacle and taking two or more steps backwards.
- c. Letting go of the gate or dropping the rope gate.
- d. Use of hand to instill fear or praise.
- e. Ground tie - second rein not touching ground.
- f. Stepping outside the confines of, falling or jumping off or out of an obstacle with designated boundaries with more than one foot once the foot has entered the obstacle; including missing one element of an obstacle on a line of travel with two feet.



- g. Blatant disobedience (kicking out, bucking, rearing or striking)
- h. Holding the saddle with either hand.
- i. Failure to demonstrate correct gait between obstacle as designated.

**10 Point Penalty**

- a. Unnatural ranch horse appearance (Horse's tail is obvious and consistently carried in an unnatural manner in every maneuver)

**Off-Pattern (OP):**

- a. Incomplete maneuver
- b. Eliminating or adding a maneuver
- c. 3rd refusal
- d. Repeated blatant disobedience
- e. Failure to dally and remain dallied during the drag
- f. Use of two hands (except junior and level 1 horses shown in a snaffle bit/hackamore)
- g. More than one finger between split reins or any fingers between romal reins (except in the two-rein)
- h. Failure to open and shut gate
- i. Failure to complete gate.

Exhibitors cannot place above others who complete pattern correctly.

**Disqualification (DO):**

- a. Lameness
- b. Abuse
- c. Leaving working area before pattern is complete
- d. Illegal equipment
- e. Disrespect or misconduct
- f. Improper western attire
- g. Fall of horse/rider.

J. **FAULTS**- which occur on the line of travel between obstacles, are to be scored according to severity:

- 1. Head carriage too high or too low.
- 2. Over-flexing or straining neck in carriage so the nose is carried behind the vertical.
- 3. Excessive nosing out
- 4. Opening mouth excessively

K. Show management, when setting course s, should keep in mind that the idea is not to trap a horse, or eliminate it by making an obstacle too difficult. All courses and obstacles are to be constructed with safety in mind so as to eliminate any accidents. When the distances and spaces are measured between all obstacles, the inside base to inside base measurement of each obstacle considering the normal path of the horse, should be the measuring point. Enough space must be provided for a horse to jog [at least 30 feet] and lope [ at least 50 feet] for judges to evaluate these gaits.

L. If disrupted, the course shall be reset. In the case that an obstacle is used in combination, the obstacle cannot be reset until the contestant finishes the entire obstacles.

M. A minimum 6 obstacles must be used, three of which must be from the mandatory list of obstacles and at least three others elected from the list of optional obstacles.

**N. OPTIONAL OBSTACLES**

- 1. The Gate - A contestant must open, go through and then close a gate. Reins may not be switched between hands unless done prior to or immediately after this obstacle.
- 2. Stationary Steer - This obstacle is used to show the willingness of the horse o have a rope thrown from its back. The judge shall give credit to the horse that stands quietly while the competitor makes the swing and throws at the steer. The Contestant shall not be penalized for a miss but shall receive credit or the horse being in correct position and standing quietly. Shying from rope will be penalized.

- i. Exhibitor has the option to carry their own rope (and as they approach steer may build loop) or be handed a coiled rope without loop). All Exhibitors are required to build own loop. Fast and efficient loop build and put away after roping should be rewarded. Only one loop will be allowed.
3. Bridge – Horse shows willingness to walk across obstacle designed to simulate a bridge.
4. Mail Box - Rider approaches mailbox, opens and then closes the door.
5. Slicker - Rider approaches slicker, removes slicker from holder, wears slicker and then travels to second holder, where he removes the slicker and replaces it on the holder.
6. Water Hazard - Horse shows willingness to cross small ditch or hallow pond.
7. Log Drag - Rider will be handed or pick up rope and drag log according to posted pattern to show horse's willingness and ability to pull. Exhibitors must dally during log drag. Once the circle is completed, the rider will drop the rope and continue to next obstacle.
8. "L"Shaped Back Through - Course made of logs or poles laid on the ground. Minimum space between poles to be 28".
9. Ground Tie or Hobble - Horse shall remain in place while his rider dismounts and performs a normal ranch task. Split reins - both reins must touch the ground. Romal reins must be hobbled.
10. Side pass - Logs or poles used must be a minimum of six feet long. Obstacles may be approached from either end and horse may be required to move both directions and such information is to be stated on posted pattern.
11. Obstacle containing four (4) logs - Each being 5'(minimum) to 6' long laid in a square and execute a 180 or 360 degree turn and then leave square or lope through the square providing the rails are 6' to 7' in length and no more than 12" high. The pattern must state which is required.
12. Logs - Three logs will be placed on ground that the contestant must cross. Walk over 15"-24" Trotover - 2'6" to 3'6" Lope over - 6' to 7'
13. Obstacles consisting of cones or pylons - Horse are to trot through in either a cloverleaf or serpentine pattern or back through as posted on pattern. Markers are to be spaced a least 3' apart.
14. Any other safe and negotiable obstacle which could reasonably be expected to be encountered on a trail ride and that meets the approval of the judge may be used.
15. A combination of two or more of any obstacle is acceptable.

**O. Unacceptable obstacles:**

1. Tires
2. Animals other than cattle
3. Hides
4. PVC pipes
5. Jumps
6. Rocking or moving bridges
7. Water box with floating or moving parts
8. Flames, dry ice, fire extinguishers, etc. \
9. Logs or poles elevated in a manner that permits such to roll

**P. Ranch Trail Credits:**

1. Credit to be given to horses negotiating the obstacles with style and some degree of speed, providing that correctness is not sacrificed.
2. Horses should receive credit for showing attentiveness to obstacles and capability of picking their own way through the course when obstacles warrant it, and willingly respond to rider's cues on more difficult obstacles.
3. Quality of movement and cadence should be part of the maneuver score for the obstacle.

**Ranch Confirmation**

The purpose of this class is to preserve American Quarter Horse type by selecting well-mannered individuals in the order of their resemblance to the breed ideal and that are the most positive combination of balance, structural correctness, and movement with appropriate breed and sex characteristics and adequate muscling. The ranch conformation class must be held after the conclusion of the other four events.

- a. All sexes will be shown together as one class.
- b. Horses are to be shown in a good working halter: rope, braided, nylon or plain leather. Horses will walk to the judge one at a time.

- c. As the horse approaches, the judge will step to the right to enable the horse to trot straight to a cone placed 50 feet away. At the cone, the horse will continue trotting, turn to the left and trot toward the left wall or fence of the arena. After trotting, horses will be lined up head to tail for individual inspection by the judge.
- d. The judge shall inspect each horse from both sides, front and rear and place the horses in order of preference.

### **HALTER CLASSES (not in the Ranch Division)**

Only the horse will be judged on conformation, condition and soundness. The horse should be well-groomed, with shoes or proper trimming. 4-H'ers should be properly attired and must prepare their own animals for the class without assistance except in holding, leading, and loading.

Concerning ponies and miniature horses in their halter class, they should be measured at 52 inches or less. All ages of mares and geldings will compete in the same class.

# SPEED DIVISION

**Personal Attire: Same as Western Division**

**Tack and Equipment: See Western Division**

In roping, speed classes and goat tying, western-type equipment must be used. Bits, bridles, tie-downs, nose bands, protective boots, and leg wraps are the optional choice of the contestant; however, the judge may prohibit the use of equipment that may be considered severe. No bare metal may be in contact with the horse's head.

No rerun will be given due to faulty or broken equipment furnished by the contestant or due to accident to horse or rider. The battery digital clock will be the first backup time, and digital hand-held watches to be second backup time. When both the digital clocks malfunction and no time was recorded from digital watches, contestant will be given a rerun at the time designated by the judges and arena director, plus any penalties. Contestants will carry any penalties with them if they are granted a rerun. If the speed event is removed, postponed or rerun for safety reasons due to ground condition, reruns will be penalty-free.

Exhibitors are **required** to wear a helmet in each speed event class (barrels, poles, stake, flag, and keyhole races). The helmet must fit and be worn properly. ASTM approved helmets are required in all speed events. Exhibitors may not be tied, buckled or fastened in the saddle in any manner by any means during competition. Rubber bands are allowed but may not exceed a ½ inch in width.

In the Speed Events, the arena will be dragged after 10 runs and between classes, with the exception of Keyhole Race and Flag Race.

## **GENERAL RULES:**

1. Each contestant will enter the arena from within a designated area behind the arena gate. Arena conditions and show management will determine where the run will begin and end. The gate in speed events may be closed unless show management determines otherwise for safety reasons.
2. The contestant is allowed a running start. Timing shall begin as soon as the horse reaches the starting line and will be stopped when the horse passes over the finish line.
3. An electric timer, when accessible, will be the official time. Otherwise, at least two watches shall be used, with the average time of the two watches to be the official time. Starting line markers or electric timers, when possible, shall be placed against the arena fence.
4. The judge, at his or her discretion, may disqualify a contestant for excessive use of a bat, crop, whip or rope in front of the cinch.
5. In the event of a tie, the contestants will flip a coin to determine the winner.
6. In the event of show management problems (i.e.: timer malfunction, etc.), the contestant will receive a rerun. The contestant shall have the option of performing the rerun immediately or electing to move to the end of the class and rerun.
7. No assistance, to either horse or rider, is permitted past the arena gate or rope barrier.
8. Exhibitors may not be tied, buckled or fastened in the saddle in any manner by any means during competition. Rubber bands are allowed but may not exceed ½ inch in width.

## **BARREL RACING**

1. Knocking over a barrel shall carry a five (5) second penalty. Failure to follow the course shall cause disqualification. A superintendent, ring steward or some other official may be designated to make these calls in the absence of the official show judge.
2. The course must be measured exactly. If the course is too large for the available space, then the pattern should be reduced five yards at a time until the pattern fits the arena. Adequate space should be left between barrels and obstacles.
3. Western-type equipment must be used. Use of mechanical hackamore or other type of bridle is optional; however, the timer or judge may prohibit the use of bits or equipment that he may consider severe.

4. Barrel racing is a timed event. Each contestant will begin from a running start. An electric timer, when accessible, will be the official time. Otherwise, at least two watches shall be used, with the average time of the watches to be the official time.
6. The contestant is allowed a running start. Timing shall begin as soon as the horse reaches the starting line, and will be stopped when the horse passes over the finish line. Arena conditions and show management will determine where the run will begin and end.
7. Set the course so that a horse may have ample room to turn and stop. (All barrels need to be at least 21 feet from the fence.)
8. In the event of a timer malfunction or show management problems, the contestant will receive a rerun at the end of the class. Contestants running toward the lower end of the working order will be allowed a reasonable length of time before they are asked to rerun.

### BARREL RACING CONTEST

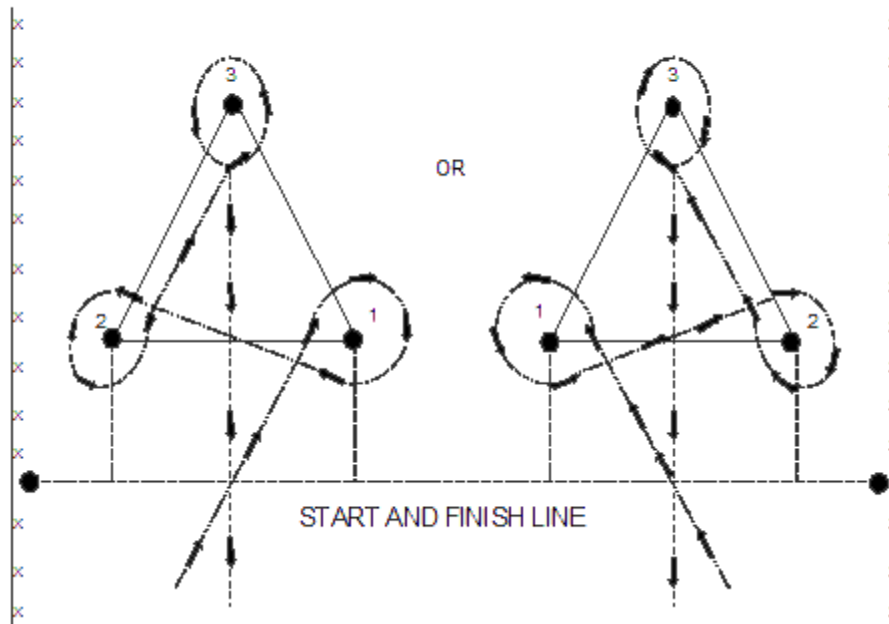

## POLE BENDING

1. The pole bending pattern is to be run around six poles. Each pole is to be 21 feet apart, and the first pole is to be 21 feet from the starting line.
2. A horse may start either to the right or to the left of the first pole and then run the remainder of the pattern accordingly.
3. Knocking over a pole shall carry a five (5) second penalty. Touching the pole with the rider's hand is allowed. Failure to follow the course shall cause disqualification. A superintendent, ring steward or some other official will be designated to make these calls in the absence of the judge.
4. Pole bending is a timed event. Each contestant will begin from a running start. An electric timer, when accessible, will be the official time. Otherwise, at least two watches shall be used, with the average time of the watches to be the official time.
6. Western-type equipment must be used. Use of mechanical hackamore or other type of bridle is optional; however, the timer or judge may prohibit the use of bits or equipment that he may consider severe.

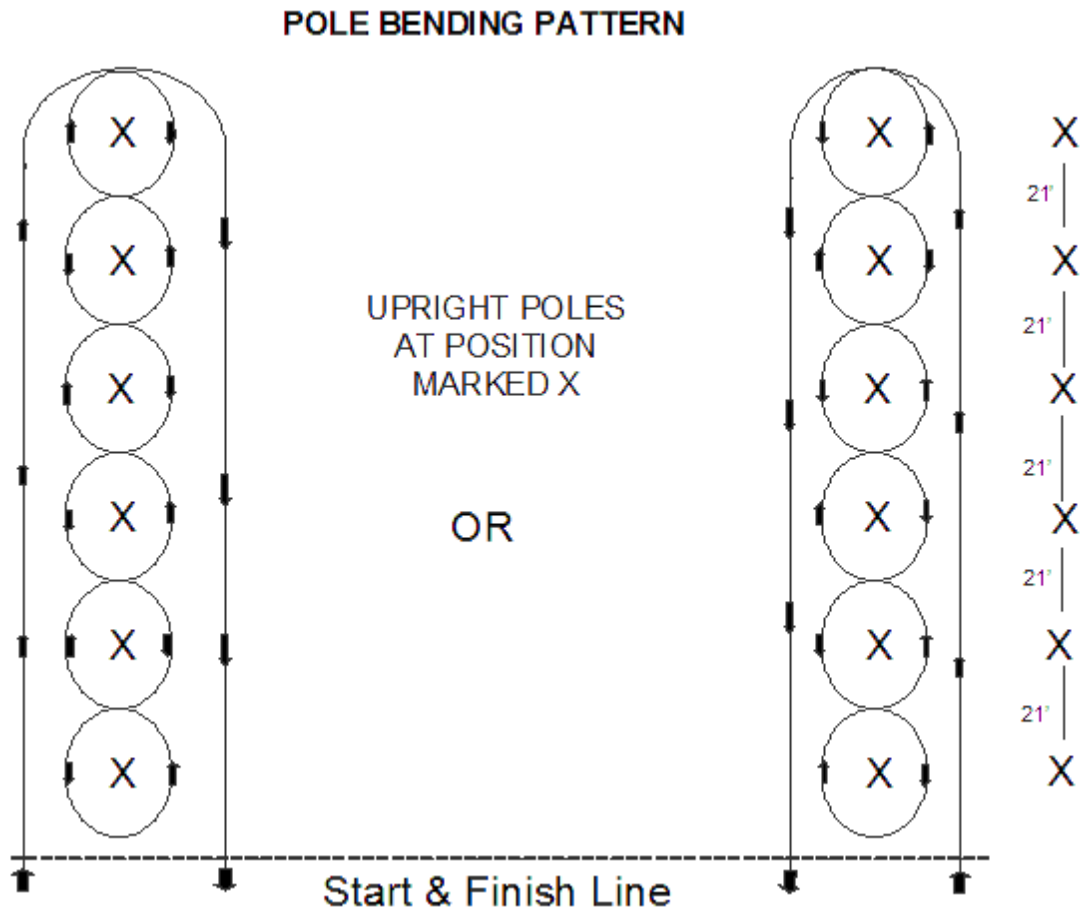

## STAKE RACE

1. The contestant is allowed a running start. Timing shall begin as soon as the horse's nose reaches the starting line and will be stopped when the horse's nose passes over the finish line. Start by crossing center line between the upright markers or running in straight line on left or right side. Pattern must be run as shown in the diagram and finish by crossing the center line.

The contestant starts between the two center markers and runs a pattern around the two end poles. The first run may be either left or right; however, the second turn must be opposite of the first.

2. This is a timed event. If an upright marker is knocked down, there is no time.
3. Upright markers are set 40 feet on either side of the center line. Two upright markers will be placed on the starting line 20 feet apart (10 feet on each side of mid-line). If an electric timer is used, it is suggested that rubber cones, short enough so as not to interfere with the timer, be used.
4. Contestant must finish line between the markers. Failure to do so shall result in disqualification.

## STAKE RACE PATTERNS

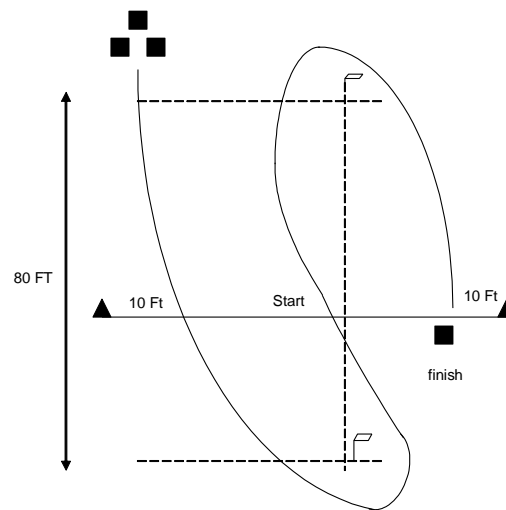
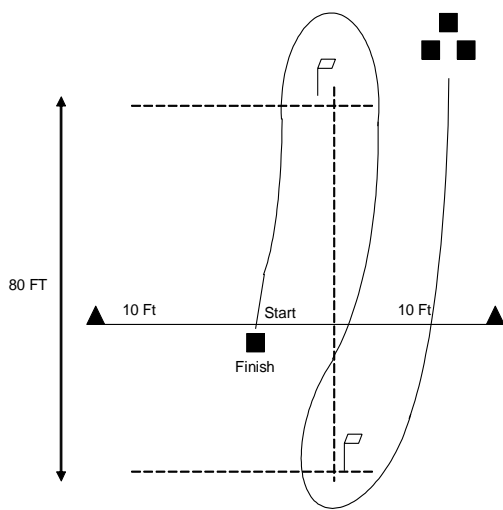
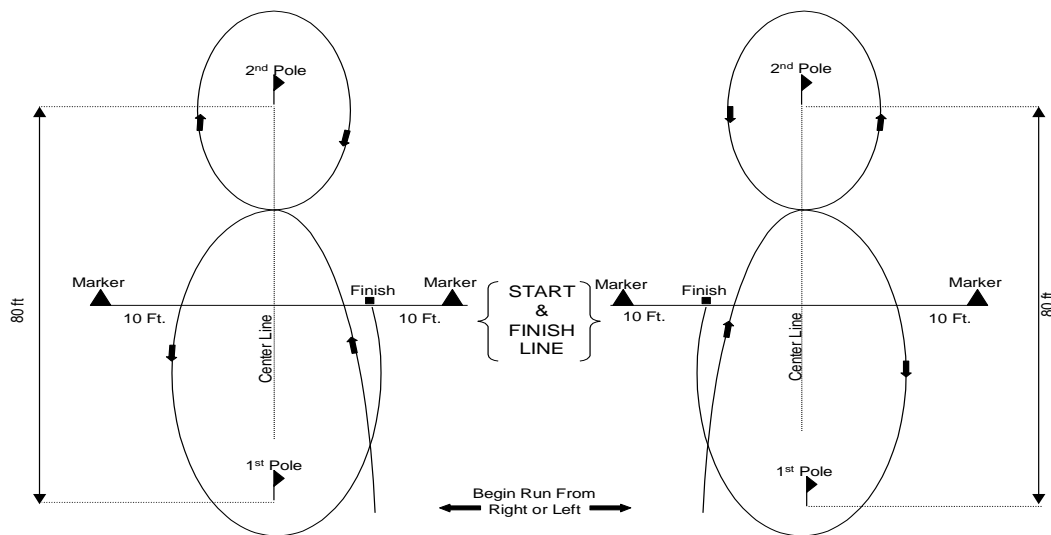

## FLAG RACE

1. Contestants will pick up the flag out of the bucket, ride around the center barrel and put the flag in the bucket on the opposite side of the arena. Stick section must be in the bucket to qualify.
2. Contestants may start from either side of the arena.
3. Contestants will be disqualified for:
  - a. Dropping the flag during the race
  - b. Striking the horse with the flag
  - c. Knocking over a barrel(s)
  - d. Knocking the bucket(s) off the barrel
  - e. Failure to keep flag in second bucket
4. Buckets will be filled with sand three inches from top of bucket. Buckets will be placed on the inside edge of the barrel.
5. The flag must be unrolled when placed in the bucket for the rider to pick up. Flag handle will be 18 inches long and one inch in diameter; flag will be 10 inches by 11 inches.
6. Rider picks up the flag at point A, rides to the opposite end of arena and around the barrel at point B and places the flag in the container at point C. Pattern may be run in reverse from point C to point A.

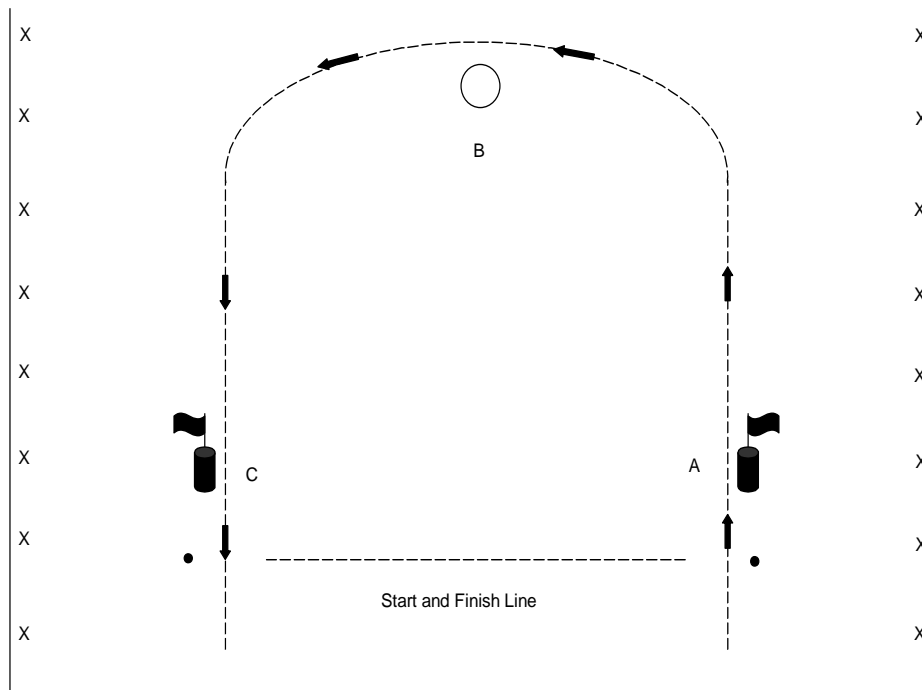



## KEYHOLE RACE

- a. Keyhole should consist of a 12 foot circle with a 10 foot long by 5 foot wide throat (10 ft. x 5 ft.).
  - b. Horse may enter pattern with a flying start. This is a timed event. Keyhole used will be outlined in white line.
  - c. Horse must turn circle – not in throat or approach to circle.
  - d. If a horse steps on or over line, it will be disqualified, and no time will be given on the ride.
  - e. Judge must stand behind the keyhole or to the side at a safe distance.
  - f. In the event of a malfunction of the time, the rider must run again making a bona-fide attempt in the re-ride to receive a time.
- NOTE: Deliberate and intentional illegal procedures executed in order to receive a faster time will not be tolerated.

### Keyhole

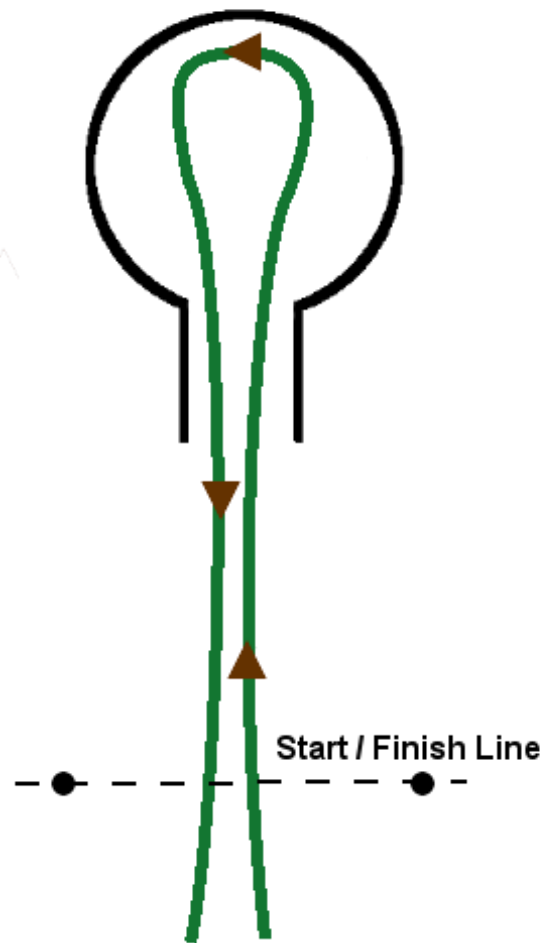

# ROPING DIVISION

**Personal Attire: Same as Western Division**

**Tack and Equipment: See Western Division**

Reruns will be determined at the discretion of the judge.

Safety helmets are optional in roping events. ASTM approved helmets are recommended.

## **BREAKAWAY ROPING**

1. This is a timed event. The same common National High School Rodeo Association conditions and standards that apply to calf-roping apply in this contest, except the roper does not dismount or tie the calf. Modifying rules follow.
2. Sixty-second time limit per exhibitor.
3. The horse must start from behind an automatic barrier. Length of the score line will be adjusted to fit arena conditions and shall not exceed one foot per 20 feet of arena length.
4. A barrier judge will be designated before the contest. If the horse breaks the barrier as a result of starting too soon, the roper will be fined a 10-second penalty. If the horse breaks the barrier as a result of failure of the barrier equipment, no penalty will be assessed. If the calf carries part of the barrier with it, or if the roper is fouled by the barrier, the roper will be given a rerun if he declares himself immediately. Once the calf is roped, no rerun will be given. Decisions of the barrier judge are final.
5. A regular rope is tied to the saddle horn, or swell, with a breakable string. Time starts at signal of the barrier flag and stops when the flagman signals that the rope breaks away from the saddle as a result of a legal catch.
6. A legal catch is defined as a loop that goes over the calf's head and draws up on any part of the body, causing the rope to break from the saddle horn.
7. Judges will rule whether the catch is legal and whether the rope breaks away as a result of a legal catch, or as a result of the horse or calf stepping on the rope, or similar occurrence. Contestants will be given no time when something other than a legal catch caused the rope to break away.
8. A piece of white (or other highly visible) cloth should be attached to the rope at the saddle horn, with no more than three feet of tail, to signal when the rope breaks away.
9. All contestants are eligible to enter the breakaway roping.
10. Only one loop will be permitted. The run must be completed in a limit of 60 seconds.

## **TIE-DOWN CALF ROPING**

1. Contest must have two judges – a field judge to flag finish of a run and a barrier judge.
2. Contestant must catch calf, dismount, go down the rope, throw the calf by hand, cross and tie any three legs.
3. If a calf is down when roper reaches it, the calf must be stood on at least three feet and be re-thrown. If the roper's hand is on the calf when calf falls; the calf is considered thrown by hand. The rope must stay on the calf until the roper gets a hand on the calf. Ties must be finished with a half hitch or "hooley."
4. Ties must hold for five seconds after roper gives slack to the calf, and then must be passed on the field judge. A roper will be disqualified if he touches the calf after he signals the finish of a tie. No person may touch the calf until the field judge evaluates the tie.
5. Any catch on any part of the calf with rope will be considered legal.
6. A barrier must be used with a minimum of four feet score line. Score line shall not exceed one foot per 20 feet of arena length.
7. If barrier is broken in any place other than a designated place, or if the ring does not fall within eight feet of a post, the barrier will not be considered broken.
8. If any part of the barrier fails to work and such failure results in disadvantage to the roper, the roper may request calf over, at the discretion of barrier judge, if he declares himself immediately. Once the calf is roped at, no roper will receive calf over because of equipment failure.
9. If flag equipment, which signals the start of time, fails to work, the roper will receive a rerun, regardless of events of first run.
10. A flag to signal the start of time must be put on a jerk line in close location to a portion of line going around the calf's neck.
11. Barrier equipment must be inspected by the judge before each contestant competes and must be replaced if faulty.
12. A 10-second penalty will be added to the roper's time for beating or breaking the barrier.
13. Suitable calves as uniform as possible are needed. Judges and officials will eliminate any uneven calves. All calves must have been run and tied down at least once before the contest begins.
14. Calves will either be drawn or gate cut, depending upon available facilities. If a calf drawn for a roper becomes sick or injured, another calf will be drawn by the judges for that roper.
15. The roper must be ready to rope when indicated by a show official, or the calf will be turned out.
16. Calves may be roped more than once in a go-round. When so doing, numbers drawn must indicate whether the contestant competes in first of subsequent run-throughs.
17. The same person must open the gate and tail the calves for all contestants in a go-round.
18. No assistance will be allowed in the arena, including the box. Only show officials and exhibitors are permitted in the arena during competition.
19. Only one loop will be permitted. The run must be completed in a limit of 60 seconds.
20. Contestants must adjust the rope and reins in a manner that will prevent the horse from dragging a calf. If a horse drags a calf, judges may stop the horse and the roper may be disqualified.
21. If a tie comes loose, or if the calf gets to its feet before the tie has been examined and ruled a fair one, the roper will receive no time.
22. If a contestant is given the wrong calf, the contestant will compete on a calf drawn for him, and time on the incorrect calf will be disregarded.

23. If a calf gets out of the arena, timers will stop the watches when the flagman signals and the roper will get the same calf back. The roper will be given a lap and tap start with time expired when the calf got out added to this time.
24. Types of bridles or other equipment used are optional choices of the contestant; however, officials may prohibit use of any equipment they may consider excessively severe.
25. A safety helmet with chin harness is recommended, but a rider may choose a western hat or no hat. Ball caps are not acceptable.

## **TEAM ROPING**

1. There shall be a 60-second time limit.
2. Two loops per team shall be allowed. Roping steers without turning loose of the loop will be considered a no catch. A roper must dally to stop the steer. If the steer is roped by one horn, the roper is not allowed to ride up and remove the loop or put the loop over other horn or head with his hands.
3. There are only three legal head catches:
  - a. Around both horns
  - b. Half a head
  - c. Around the neck

If the honda passes over one horn and the loop over the other, the catch is illegal. If a loop crosses itself in a head catch, it is illegal.

4. Any heel catch behind both shoulders is legal if the rope goes up heels. If the heeler ropes a front foot or feet in the heel loop, this is a foul catch, unless the front comes out prior to or simultaneously of both horses facing. Judges will not allow any extra time for a front leg to come free.
5. The steer's entire body must be turned and moving forward in tow before the heel loop can be thrown. However, if the steer stops, he must only be in tow for the heel loop to be legal. Any heel loop thrown in the switch is considered a crossfire and illegal. The steer must be standing when the heel loop is thrown.
6. Should a header rope a front leg, he is not allowed to fish it out. This is an automatic no time.
7. Time will be taken when the steer is roped, secure between partners, both horses are facing the steer with ropes dallied, and rope tight. Horses' front feet must be on the ground and ropers must be mounted when time is taken. The flagger may disqualify a team after time is taken on a run, based on an illegal head catch or illegal heel catch, etc.
8. A dropped rope that must be recoiled is considered a thrown rope.
9. Should the barrier malfunction at any time during the course of the competition either for or against the roper, a rerun will be awarded at the end of the round.
10. If a contestant is visibly fouled, or he can see that he is or will be fouled, he must declare by pulling up or attempting to pull up and not try to go on with the contest. If he does not declare, he accepts the situation as it is.
11. If any animal escapes the arena, the flag will be dropped and watches stopped. Contestants will get the animal back for a lap-and-tap start and time already spent will be added to time used in qualifying. If time is not recorded, the decision of the judge will be final.
12. Barrier length will be based on the speed of the cattle and dimensions of the arena.
13. Team roping must be entered as an individual. Contestants will pick their team member at the show.

## **GOAT TYING**

### **1. Equipment:**

- a. Western-type equipment must be used.
- b. Leather thong, pigging string or rope to secure the animals.

### **2. Time Limit:**

There will be a one minute time limit to complete the tie.

### **3. General Rules:**

- a. Goats will be changed after 3 runs, unless otherwise specified by management.
- b. Clearly visible starting line shall be provided.
- c. The stake and starting line will be permanently marked.
- d. The horse's nose will be timed as it crosses the starting line.
- e. Goats to be tied: right, left, right and left, etc.
- f. Starting line will be 100 feet from the stake.
- g. The goat should be tied to a stake with a rope 10 feet in length.
- h. The stake should be completely under the ground so that no part of it is visible or above ground.
- i. The contestant must be mounted on a horse and must ride from the starting line to the goat, dismount from their horse and throw the goat by hand.
- j. If the goat is down when the contestant reaches it, goat must be stood on at least three feet (goat must be elevated by contestant so that at least three feet are dangling straight beneath the goat and goat must be re-thrown), then cross and tie any three legs together with a leather thong, pigging string or rope, and stand clear of the goat.
- k. Legs must remain crossed and secure for six seconds after completion of the tie.
- l. To qualify as a legal tie, there will be one or more wraps and half hitch, hooley or knot.
- m. Time will start when contestant crosses the starting line.
- n. Time will stop when contestant signals the completion of the tie.
- o. The contestant must move back three feet from the goat before the judge will start the six-second time limit on the tie. Goat's legs must remain crossed and tied.
- p. Qualified persons other than contestants will be used as goat holders.
- q. Contestants will receive a no time for touching the goat or tie string after signaling the tie is completed.
- r. If a contestant's horse crosses over the rope or goat, or if the contestant's horse comes in contact with the goat or rope prior to the contestant signaling for time, a ten (10) second penalty will be assessed.
- s. If the goat should break away because of the fault of the horse while the contestant is mounted, the contestant will receive no time. A contestant is still mounted until both feet are on the ground.

# Educational Contests

## HORSE JUDGING CONTEST

Teams may have three or four members. Contestants may enter as individuals (not on a team) if they choose. If only one contestant is entered from a particular county, that person will be randomly added with other contestants to make a team of three or four. Each county may enter multiple teams in either the Junior or Senior division. The two highest-scoring Senior team will be eligible to represent Arkansas at a national competition (AQHYA Youth World, Eastern Nationals, All American Quarter Horse Congress, or Denver Stock Show) as well as the Southern Regional Horse Show. Out-of-state trip expenses for the national contest (not Southern Regionals) will be provided if funding is available.

### Rules:

1. Contestants should provide their own clipboard and #2 Pencil. Scantrons will be provided at the contest.
2. Contestants may not use or possess cell phones during the contest.
3. While the contest is in progress, there will be no talking or conversation between contestants or any other individuals. All questions should be directed to group leaders.
4. Contestants will not be allowed to carry, use, or refer to any printed material at any time during the contest (only judge's score sheets). Contestants are only permitted to bring a clipboard and #2 pencil into the contest. Blank paper will be provided, as well as scantrons, scoresheets, and patterns. No other material is allowed into the contest.
5. Contestants should not use notes while giving oral reasons. Use of notes will result in a minimum penalty of 10 points. The oral reasons judge will, at their discretion, use higher penalties based on the extent of use of notes. There will be no talking during reasons preparation.
6. Awards for the contest will be:
  - a. Junior High Point Halter (3<sup>rd</sup> Tie Breaker for overall)
  - b. Junior High Point Performance (2<sup>nd</sup> Tie Breaker for overall)
  - c. Junior High Point Reasons (1<sup>st</sup> Tie Breaker for overall)
  - d. Junior High Point Overall (1<sup>st</sup> Tie Breaker for each section)
  
  - e. Senior High Point Halter (3<sup>rd</sup> Tie Breaker for overall)
  - f. Senior High Point Performance (2<sup>nd</sup> Tie Breaker for overall)
  - g. Senior High Point Reasons (1<sup>st</sup> Tie Breaker for overall)
  - h. Senior High Point Overall (1<sup>st</sup> Tie Breaker for each section)
  
  - i. Junior High Point Team Overall
  - j. Senior High Point Team Overall
7. Classes to be judged may include:
  - A. Halter Classes – American Quarter Horse, Morgan, Appaloosa, Arabian, Palomino, American Paint, and Stock Horse Type.

- B. Performance Classes – Western Pleasure, Western Horsemanship, Reining, Hunt Seat Equitation, Hunter Under Saddle, Western Riding, Hunter Hack, Trail, Ranch Rail, Ranch Trail, and Ranch Riding.
- C. Seniors may be asked to give up to two sets of reasons. Juniors may be asked to give one set of reasons.

## **HORSE BOWL CONTEST**

### *Contest Format:*

1. There will be 4 members on each team.
2. The Horse Bowl Competition will have double elimination for the contest if there are 3 or less teams. If there are more than 3 teams, a single elimination will occur.
3. Two randomly paired teams will compete in each match.
4. Each match consists of twenty One-On-One Questions (worth 5 points each), five Toss-Up Questions (worth 5 points each), and five Bonus Questions (worth 10 points each).
5. The first four one-on-one questions will be head-to-head, and each designated team member has an opportunity to answer a one-on-one question.
6. The individual that signals in first via the buzzer has five seconds to answer.
7. If answered incorrectly, the question will be reread if not initially completed, and the other team has five seconds to buzz in and answer.
8. The fifth question (toss-up) is open to any team member and if answered correctly that team will be awarded the Bonus question.
9. The team that answers the toss-up question correctly will have the opportunity to answer the bonus question.
10. Team members may confer for ten seconds prior to answering the **BONUS** question.
11. If the answer given by the team captain on a bonus question is incorrect, then neither team receives points for that question.
12. The team with the highest score wins the match.
13. If there is a tie, five tie breaking questions will be asked. The team with the highest score at the end of the tie breaking questions wins the match. If there is still a tie after the five tie breaking questions, the process will be repeated until the tie is broken.

### Suggested Sources:

- *New Horizons – Dictionary of Equine Terms*. By New Horizons Equine Education Center, Alpine Publications, Inc.
- *Evans 2<sup>nd</sup> – The Horse (2<sup>nd</sup> Edition)* by Evans, Borton, Hintz, Van Vleck, *Kainer – The Coloring Atlas of Horse Anatomy*. Dr. Robert Kainer and Dr. Thomas McCracken, Alpine Publications, Inc.
- *AYHC 1<sup>st</sup> – Horse Industry Handbook*, by the American Youth Horse Council, American Youth Horse Council.
- *AYHC Youth Leaders Manual* – by the American Youth Horse Council.
- *Lewis 2<sup>nd</sup> – Feeding and Care of the Horse (2<sup>nd</sup> edition)*, by Lon D. Lewis.
- *State line tack catalog*
- *National 4-H Horse Curriculum Books:*
  - Giddy up and Go
  - Head, Heart, and Hooves

- Stable Relationships
- Riding the Range
- Jumping to new Heights

## HIPPOLOGY CONTEST

**OBJECTIVES:** The primary objective of the hippology contest is to provide, in a friendly but competitive setting, an opportunity for youth enrolled in 4-H to demonstrate the breadth of their knowledge and understanding of equine science and management, and in particular, the practical application of this knowledge and skill. It is hoped that this contest will generate new friendships and be a rewarding experience for the contestants.

Contestants may enter as individuals (not on a team) if they choose. If only one contestant is entered from a particular county, that person will be randomly added with other contestants to make a team of three or four. Each county may enter multiple teams in either the Junior or Senior division. The highest-scoring Senior team will be eligible to represent Arkansas at a national competition (Eastern Nationals, All American Quarter Horse Congress, or Western Nationals) as well as the Southern Regional Horse Show. The second-place Senior team will be eligible to represent Arkansas at the Southern Regional Horse Show. Out-of-state trip expenses for the national contest (not Southern Regionals) will be provided if funding is available.

### CONTESTANTS AND ELIGIBILITY:

- a) Each county may enter teams of three (3) or four (4) contestants. In teams in which there are four members, all will compete, but the member receiving the lowest overall score will be automatically declared the alternate. The scores of the alternate will not be included in any of the team totals but will be considered in making all individual awards. Teams consisting of three members will have no alternate and all members' scores will count in determining individual and team awards.
- b) The teams may be selected by any procedure that the county deems to be appropriate. Team members must be enrolled in 4-H in the county they represent. Their eligibility must be certified by the county agent or 4-H leader.
- c) There will be a Junior division and a Senior division.

### 2. REFERENCE SOURCES to be used:

- *New Horizons – Dictionary of Equine Terms*. By New Horizons Equine Education Center, Alpine Publications, Inc.
- *Evans 2<sup>nd</sup> – The Horse (2<sup>nd</sup> Edition)* by Evans, Borton, Hintz, Van Vleck, *Kainer – The Coloring Atlas of Horse Anatomy*. Dr. Robert Kainer and Dr. Thomas McCracken, Alpine Publications, Inc.
- *AYHC 1<sup>st</sup> – Horse Industry Handbook*, by the American Youth Horse Council, American Youth Horse Council.
- *AYHC Youth Leaders Manual* – by the American Youth Horse Council.
- *Lewis 2<sup>nd</sup> – Feeding and Care of the Horse* (2<sup>nd</sup> edition), by Lon D. Lewis.
- *State line tack catalog*
- *National 4-H Horse Curriculum Books:*
  - Giddy up and Go
  - Head, Heart, and Hooves
  - Stable Relationships
  - Riding the Range
  - Jumping to new Heights



Grains, forages and feed preparations used in this contest will be representatives of feeds utilized in horse rations.

3. THE CONTEST:

- A. Examination phase, up to 200 points – This phase of the contest will include:
  - 1. A written exam
  - 2. Projected slides to be identified as to breed, color, color patterns, activity, proper appointments, etc.
  - 3. Anatomy which may include external, skeletal internal organs, parts of gastrointestinal tract, male and female reproductive organs, detailed anatomy of the foot and detailed anatomy of the lower limbs
  
- B. Station Phase, up to 200 points – This phase will consist of a series of stations or tables where each/all contestants will respond to the requirements of the station. Examples of stations which will be used include:
  - 1. Identification of:
    - a. Various typed of saddles (actual or pictured) and parts of saddles
    - b. Tack, bits, bridles, horseshoes and parts of shoes
    - c. Tools and equipment, and assembly of specific parts of various pieces of equipment
    - d. Grains and forages used in equine rations including various form and methods of preparation
    - e. Internal and external parasites based on actual samples, pictures, life cycle charts and/or damage caused
    - f. Blemishes and soundness
    - g. Ages of equines based on teeth
  - 2. Use of pulse rate, respiratory rate, temperature, dehydration, anemia, etc. to assess horse health.
  - 3. Measurements such as, but not limited to: wither height, shoe size, girth, collar size, gullet width, seat length of saddle, etc. may be required.
  
- C. Judging phase, up to 200 points – Contestants will be required to place at least two classes consisting of conformation and/or performance classes. Pictorial, video and/or movie classes may be used, in which case they would be especially prepared for the event.
  
- D. Team problem, up to 200 points – All teams will be presented with the same problems. Each team will have equal time to discuss the problem among themselves, immediately after which they will have to present an oral solution or series of suggested procedures relative to the problem. Each member of each team is encouraged to contribute to the oral presentation. Evaluation will be based on the understanding of the problem, completeness of the logic used in making the oral response. The official may ask questions of any or all of the team members to clarify the presentation.

EXAMPLES OF POSSIBLE TEAM PROBLEMS MIGHT INCLUDE, BUT NOT LIMITED TO:

- 1. Balancing a horse's ration.

2. Farm management recommendation for specific (i.e. breeding, training, boarding, nursery, lay-up, etc.) horse operations.
3. Considerations for the establishment of a new horse facility (stable to be used for a specific purpose).
4. Recommendations for locating, selecting, and purchasing horses for specific uses.
5. Behavior problems – causes, management of and corrections.
6. Training and conditioning programs: equipment, schedules, methods, nutrition and problem avoidance.
7. Breeding and/or leasing contracts – specific clauses for insurance, liability, payments, care, termination, transport, etc.
8. Teaching lessons in horse management (specific subject to be announced) to a group of 9- to 11-year-old beginner 4-H'ers (i.e. where, how long, how much information, hands-on experience, reinforcement, testing evaluation.)
9. Explanation of use or assembly of specific equipment will be considered.
10. Demonstrate skill or ability to use specific equipment.

Team problem scores will not be included in determining the rank of individuals in the contest, but will be added to the team scores of the other three phases to determine overall team standing.

4. **TIEBREAKING AND AWARDS:**

1. Junior Exam High Point (3<sup>rd</sup> Tie Breaker for overall)
2. Junior Station High Point (1<sup>st</sup> Tie Breaker for overall)
3. Junior Judging High Point (2<sup>nd</sup> Tie Breaker for overall)
4. Junior High Point Overall (1<sup>st</sup> Tie Breaker for each section)
  
5. Senior Exam High Point (3<sup>rd</sup> Tie Breaker for overall)
6. Senior Station High Point (1<sup>st</sup> Tie Breaker for overall)
7. Senior Judging High Point (2<sup>nd</sup> Tie Breaker for overall)
8. Senior High Point Overall (1<sup>st</sup> Tie Breaker for each section)
  
9. Junior High Point Team Overall
10. Senior High Point Team Overall

**TEAM PRESENTATION CONTEST**

1. **OBJECTIVES:** The primary objective of the team presentation contest is to provide, in a friendly but competitive setting, an opportunity for youth enrolled in 4-H to demonstrate their knowledge and understanding of a specific equine-related topic, and present that topic to an audience. It is hoped that this contest will generate new friendships and be a rewarding experience for the contestants. Each county may enter multiple teams. The two highest-placing teams overall (Junior and Senior division) will be eligible to represent Arkansas at the Southern Regional Horse Show as well as Eastern Nationals or Western Nationals.
2. Working orders will be drawn and posted in advance of the contest. The working order may be changed to accommodate 4-H members when conflicts arise with the horse show classes.
3. May be a demonstration or illustrated talk.
4. A team will consist of two members. Teamwork should be demonstrated.

5. Subject must pertain to the horse industry. (No live animals may be used.)
6. Ten to 15 minutes will be allowed for each demonstration, with a penalty of 1 point per judge subtracted for each minute or fraction of a minute over or under the time limits.
7. The following equipment will be provided for the contestants use: two (2) tables, two (2) easels, one screen, computer, projector, and one power cord.
8. Consideration and points on the scorecard will be:

a) Introduction (10 Points)

- 1) Did the introduction create interest in the subject?
- 2) Was the introduction short and to the point?

b) Organization (25 Points)

- 1) Was only one main idea demonstrated?
- 2) Did the discussion relate directly to each step as it was shown?
- 3) Was each step shown just as it should be done in an actual situation, or was an explanation given for discrepancies?
- 4) Could the audience see each step?
- 5) Were materials and equipment carefully selected, neatly arranged and well-organized?
- 6) Were charts and posters used if and when needed?
- 7) Were the key points for each step stressed?

c) Content and Accuracy (25 Points)

- 1) Were facts and information presented accurately?
- 2) Was enough information presented about the subject?
- 3) Were approved practices used?
- 4) Was credit given to the sources of information if it was appropriate?
- 5) Was the content appropriately related to the horse industry?

d) Stage Presence (10 Points)

- 1) Were the demonstrators neat and appropriately dressed for the subject of demonstration?
- 2) Did the demonstrators speak directly to and look at the audience?
- 3) Was the demonstration too fast or too slow?

e) Delivery (15 Points)

- 1) Did the demonstrators appear to enjoy giving the demonstration?
- 2) Did the demonstrators have good voice control?
- 3) Were all words pronounced correctly?
- 4) If notes were used, was it done without distracting from the speech?
- 5) Did the demonstrators seem to choose words at the times they were spoken instead of memorizing the demonstration?

f) Effect on Audience (5 Points)

- 1) Did the audience show an interest in the demonstration?
- 2) Could the audience go home and use the idea?

g) Summary (10 Points)

- 1) Was the summary short and interesting?
  - 2) Were the key points briefly reviewed?
  - 3) Did the summary properly wrap up the demonstration?
  - 4) Could demonstrators handle questions easily?
9. Contestants may use notes, but excessive use of notes may be counted against the contestant. This will be at the discretion of the judge or judges.
  10. Contestants should cite their major references after the conclusion of their presentation. This will not be counted in the allotted time.
  11. Questions will be asked by judges only.

### **INDIVIDUAL PRESENTATION CONTEST**

Same rules and scorecard as for Team Presentation.

Exceptions:

1. This is an individual contest.
2. Presentations should be 9-12 minutes in length. One point per judge will be deducted from the score for every minute or fraction of a minute under or over the time limits. Each county may enter multiple contestants. The two highest-placing individuals overall (Junior and Senior division) will be eligible to represent Arkansas at the Southern Regional Horse Show as well as Eastern Nationals or Western Nationals.

### **PUBLIC SPEAKING CONTEST**

**OBJECTIVES:** The primary objective of the public speaking contest is to provide, in a friendly but competitive setting, an opportunity for youth enrolled in 4-H to demonstrate their knowledge and understanding of a specific equine-related topic, and present that topic to an audience. It is hoped that this contest will generate new friendships and be a rewarding experience for the contestants. Each county may enter multiple contestants. The two highest-placing individuals overall (Junior and Senior division) will be eligible to represent Arkansas at the Southern Regional Horse Show as well as Eastern Nationals or Western Nationals.

1. Subject must pertain to the horse industry.
2. Seven to 10 minutes will be allowed for each speaker, with 1 point per judge subtracted for each minute or fraction of a minute over or under the time limit.
3. Contestants may use notes, but excessive use of notes may be counted against the contestant. This will be at the discretion of the three judges. Powerpoint slide shows are not to be used.

4. Consideration and points on the scorecard will be:

a) Introduction (10 Points)

- 1) Did the introduction create interest in the subject?
- 2) Was the introduction short and to the point?

b) Organization (15 Points)

- 1) Were the main points easy to follow?
- 2) Were the main points arranged in the best order?
- 3) Were the sentences short and easy to understand?
- 4) Was the speech interesting?

c) Content and Accuracy (20 Points)

- 1) Were the facts and information accurate?
- 2) Was there enough information concerning the subject?
- 3) Was credit given to the sources of information, if appropriate?
- 4) Was the content appropriately related to the horse industry?

d) Stage Presence (15 Points)

- 1) Was the speaker neat and appropriately dressed?
- 2) Did the speaker talk directly to and look at the audience?
- 3) Was the speaker's posture erect, but not stiff?
- 4) Did the speaker refrain from leaning on the lectern?
- 5) Did the speaker seem relaxed and at ease?

a) Delivery (20 Points)

- 1) Did the speaker have appropriate voice control?
- 2) Were all the words pronounced correctly?
- 3) Did the speaker's facial expressions reflect the mood of the speech?
- 4) If notes were used, was it done without distracting from the speech?
- 5) Did the speaker seem to choose words at the time they were spoken, instead of memorizing or reading the speech?

f) General (10 Points)

- 1) Did the speaker convey to the audience a sense of wanting to communicate?
- 2) Did the speech reflect the thoughts and personality of the speaker?

g) Conclusion (10 Points)

- 1) Was the conclusion short and interesting?
- 2) Did the conclusion properly wrap up the speech?
- 3) Could the speaker handle questions easily?